

15-kV Safefront Mini-Switch Source Isolated Pad-Mounted Switchgear

140 Amp (Max) Clip-Mounted Current-Limiting Fuses

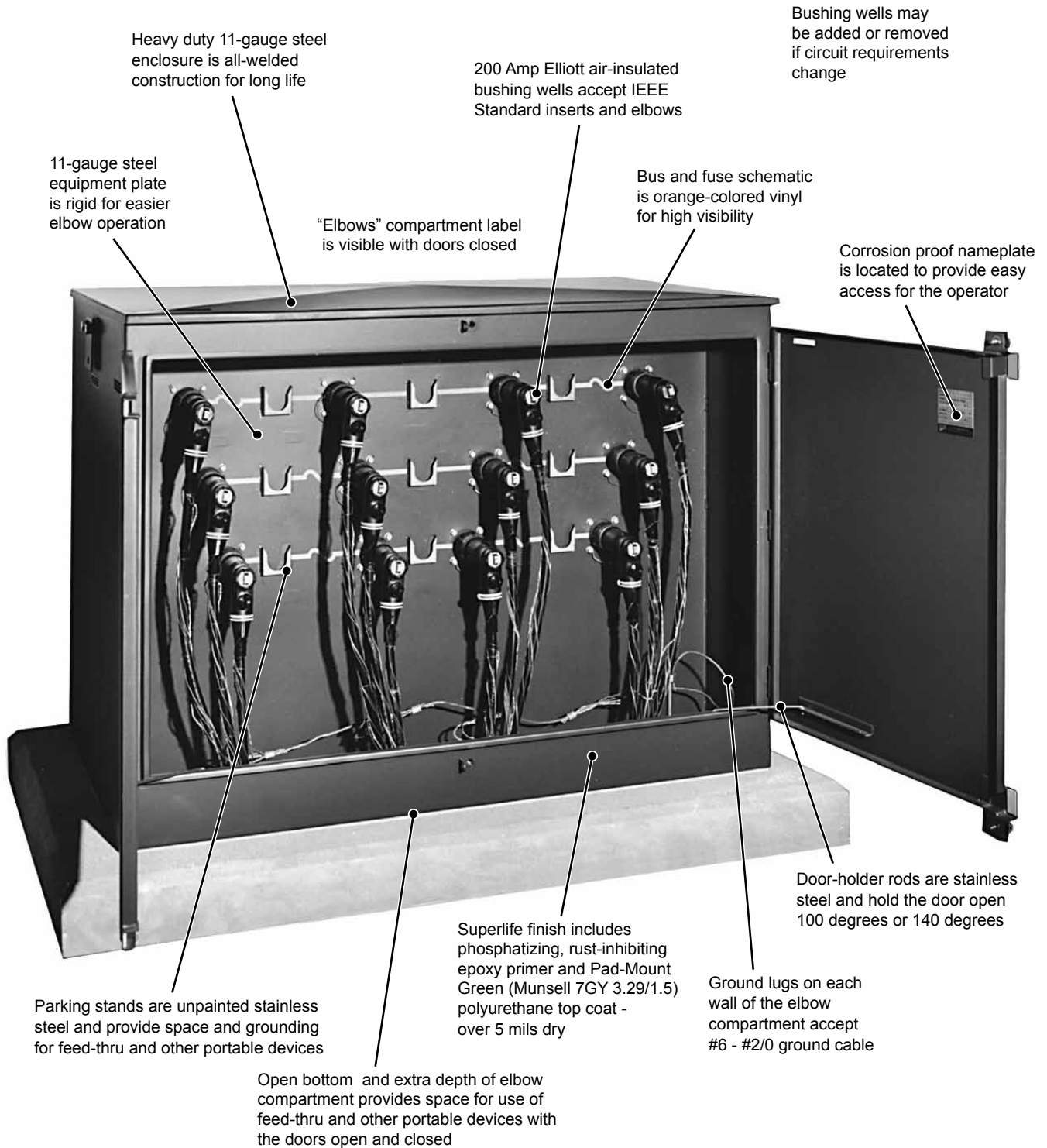

ENCLOSURE OPTIONS:

- 1) 0.125" #5052H32 Aluminum
- 2) 12-gauge #304L Stainless Steel

15-kV Safefront Mini-Switch Source Isolated Pad-Mounted Switchgear

140 Amp (Max) Clip-Mounted Current-Limiting Fuses

Removable lift provisions with blind holes for tamper resistance

Door safety barrier removal instructions

"Fuses" compartment label is visible with doors closed

"Danger - Keep Out! Hazardous voltage"

Safety latches on the door safety barrier are insulating and require a positive action to remove the door safety barrier

Barrier lift handles are insulating and keyed to prevent rotation

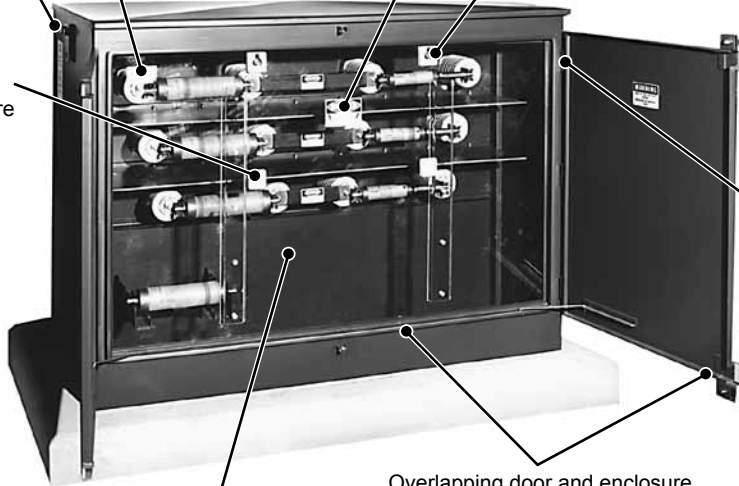

Field-Proven Components including Elliott bushing wells specifically designed for "in-air" operation gives you long-term reliable service

Standard Cable Training means quick, economical installation and assures proper operation for the life of the equipment

Deep Elbow Compartment and careful placement of bushing wells and parking stands makes switching and grounding easier and safer

Tamper-Resistant Enclosure meets National and Regional Enclosure Integrity Standards and virtually eliminates the entrance of airborne contamination to reduce maintenance

Stainless steel hinges are welded to the door and the enclosure - 0.375" pins are standard

Clear-polycarbonate door safety barriers (fuse side only) allows visual inspection without removal

Overlapping door and enclosure flanges - with other features - provide tamper resistance to meet national and regional standards

300 Amp copper bus has rounded corners and is de-burred for corona free operation

Cross-kinked roof prevents standing moisture

"Danger - Do not remove fuse under load"

Fuse clips mount on bushing wells with copper-to-copper connections and are keyed to prevent rotation

"In-Air" Insulation eliminates leaking or contamination of insulating medium for long trouble-free operation

"In-Air" Visibility allows visual inspection of all components without the inconvenience or expense associated with equipment which must be de-energized for inspection

"In-Air" Accessibility means every connection may be checked and tightened using hot stick tools without de-energizing the equipment

Fuse mountings accept Eaton's Cooper Power Systems NX® full range current-limiting fuses and other manufacturers equal

Glass reinforced barriers meet NEMA GPO-3 Standards

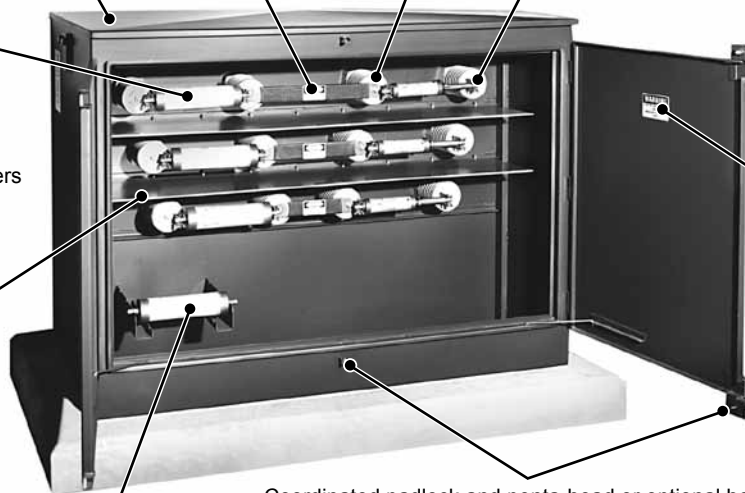

"Warning - Park the loadside elbow before removing fuse"

Optional spare fuse storage provisions

Coordinated padlock and penta-head or optional hex-head bolt (top and bottom) provides bolted-door security with visual confirmation by supervisory personnel. Security bolt is made captive with a stainless steel washer compressed to an oval shape to severely discourage removal

Standard Cable Training

The Source Isolated Safefront Switchgear shown in this Bulletin was designed to cable train for easy operation when the cables enter the switchgear in conduit and when the cables are direct buried. The need to design for different types of cable entrance is eliminated. In addition, "A" phase cables are longer than "B" phase cables and "B" phase cables are longer than "C" phase cables to reduce the possibility of switching error. Generous space is provided at every parking stand to allow use of a parking or feed-thru accessory. Installation as shown on the recommended Cable Training drawings (in this Bulletin) assures your operator he can perform all necessary switching operations, including parking, feed-thru and grounding. As shown, switchgear with one circuit arrangement can be replaced by switchgear with a different circuit arrangement and the existing cables need not be re-terminated.

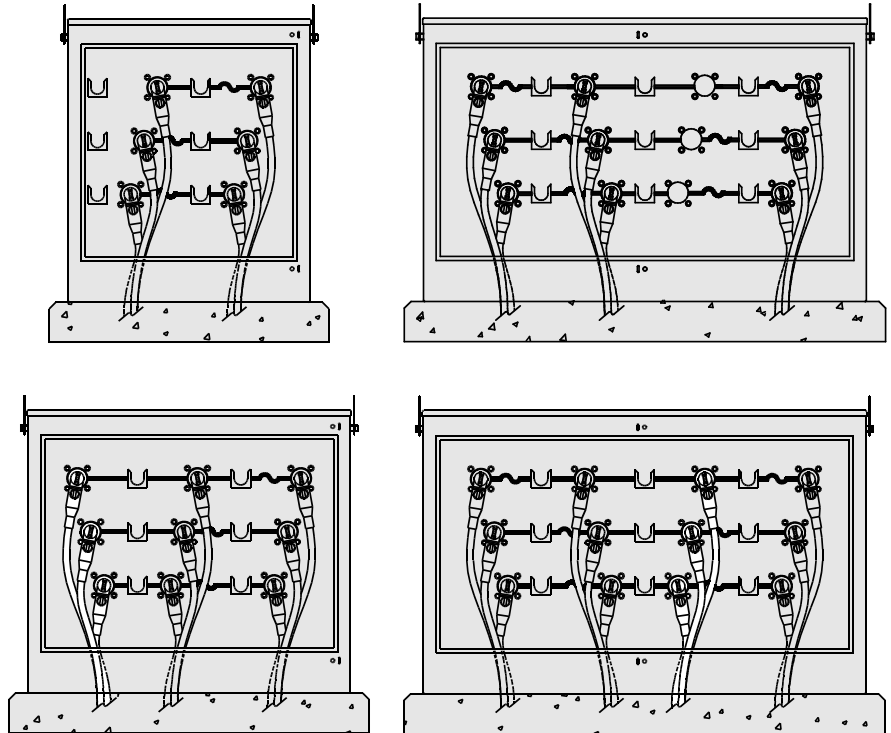

Selecting Switchgear

The Switchgear shown in the following circuit diagrams is rated 8.3/14.4 kV Grounded Wye Maximum design. Dimension drawings and recommended cable training for each design can be found on pages 4 through 11 of this bulletin. The continuous-current rating of the copper bus is 300 amperes. The continuous-current rating of the bushing well is 200 amps with an eight hour overload rating of 300 amps. Maximum fuse size is 140 amperes utilizing Eaton's Cooper Power Systems Clip-Mounted NX® or X-Limiter™ full range current-limiting fuses (and other manufacturers equal). Elliott Air-Insulated Bushing Wells are designed for "in-air" operation and accept Elastimold®, Eaton's Cooper Power Systems and other 15 kV class IEEE

loadbreak bushing inserts and elbow terminators. Each model can be ordered with or without the clip-mounted fuses (fuse sizes and description are found on page 16 of this bulletin). All loadbreak or loadmake operations must be accomplished with the loadbreak elbow terminators – clip-mounted fuses are not loadbreak devices. Two ground connectors, which accept #6 through #2/0 cable, are included and are installed as shown by the drawings. Spare-fuse holders (mounted below the lower bushings) can be supplied as an optional item.

The Typical Specification on pages 12, 13 and 14 describes the design, construction and available alternate fuse options.

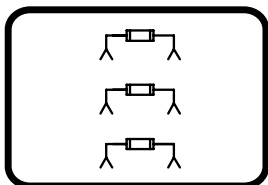

— 311S —

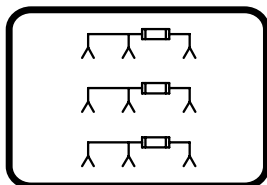

— 321S —

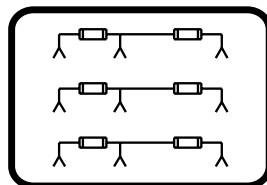

— 312S —

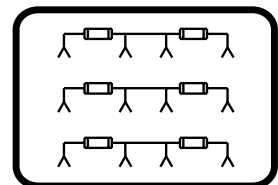

— 322S —

Safefront (elbow-terminated) Switchgear is available in other designs and voltage ratings. If you do not find a model to fit your need, please contact our representative or the factory.

Cable Training and Anchor Bolt Locations

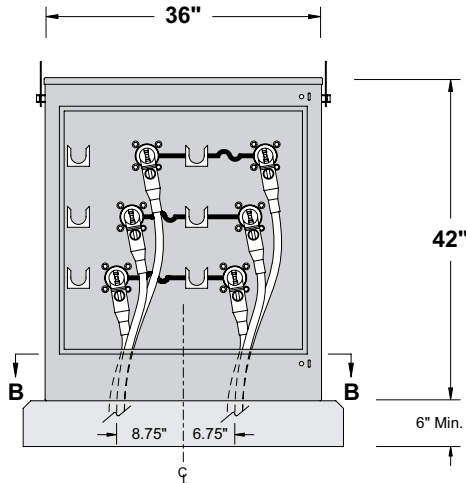

Front View
Door Removed

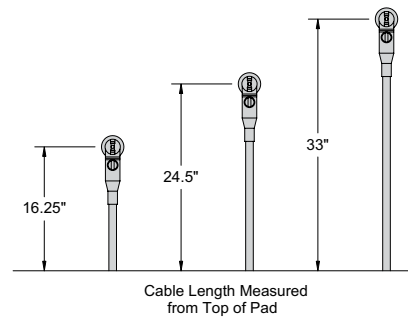

Cable Length Measured from Top of Pad

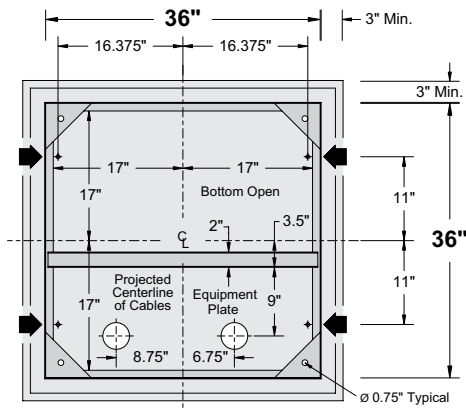

Section BB
and Typical Pad Dimensions

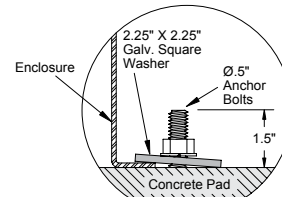

Alternate #1

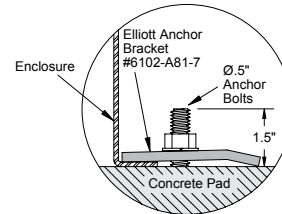

Alternate #2

Catalog Number	Fuse Mounting	Dimensions
EPMR-15-311S-E2-CM5	8.3 kV (Code 5) 1.5 to 140 Amp Clip Mounted Current-Limiting Fuse	Dimensions are listed above
EPMR-15-311S-E2-CM6	15.5 kV (Code 6) 1.5 to 125 Amp Clip Mounted Current-Limiting Fuse	Contact our Representative or the Factory for drawings

When additional cable terminating space is required, a 48" or 54" high enclosure can be supplied to increase cable terminating space by 6" or 12". To order a 48" high enclosure, suffix the catalog number "-48H". To order a 54" high enclosure, suffix the catalog number "-54H".

15-kV Safefront Mini-Switch Source Isolated Pad-Mounted Switchgear

140 Amp (Max) Clip-Mounted Current-Limiting Fuses

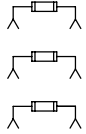

Three-Phase – Two Ways Per Phase
200 Amp Elliott Air-Insulated Bushing Wells
8.3/14.4 kV Grounded Wye Max Design
95 kV BIL

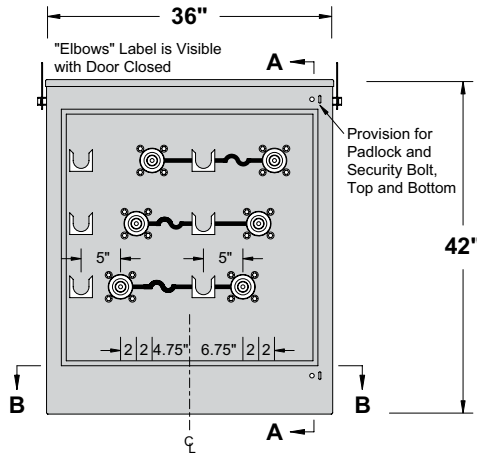

Front View
Door Removed

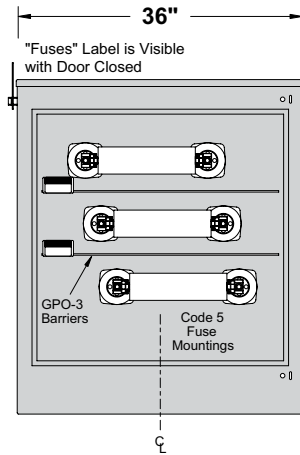

Rear View
Door & Door Safety
Barrier Removed

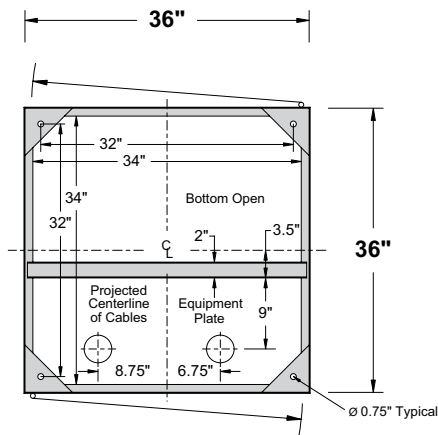

Section BB

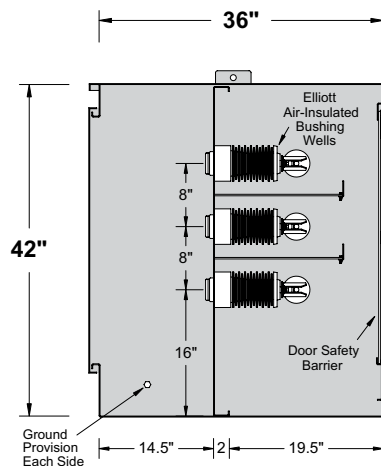

Section AA

Catalog Number	Fuse Mounting	Dimensions
EPMR-15-311S-E2-CM5	8.3 kV (Code 5) 1.5 to 140 Amp Clip Mounted Current-Limiting Fuse	Dimensions are listed above
EPMR-15-311S-E2-CM6	15.5 kV (Code 6) 1.5 to 125 Amp Clip Mounted Current-Limiting Fuse	Contact our Representative or the Factory for drawings

When additional cable terminating space is required, a 48" or 54" high enclosure can be supplied to increase cable terminating space by 6" or 12". To order a 48" high enclosure, suffix the catalog number "-48H". To order a 54" high enclosure, suffix the catalog number "-54H".



15-kV Safefront Mini-Switch Source Isolated Pad-Mounted Switchgear

140 Amp (Max) Clip-Mounted Current-Limiting Fuses

Bulletin
400-110
Page 6 2018

Cable Training and Anchor Bolt Locations

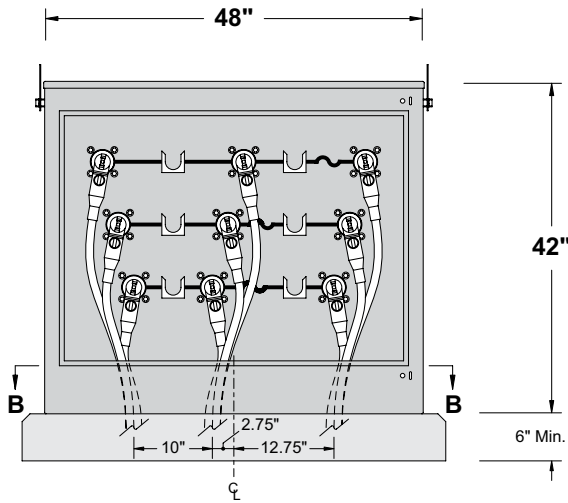

Front View
Door Removed

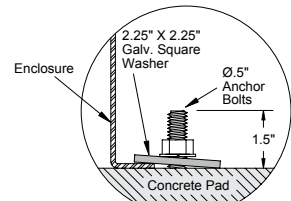
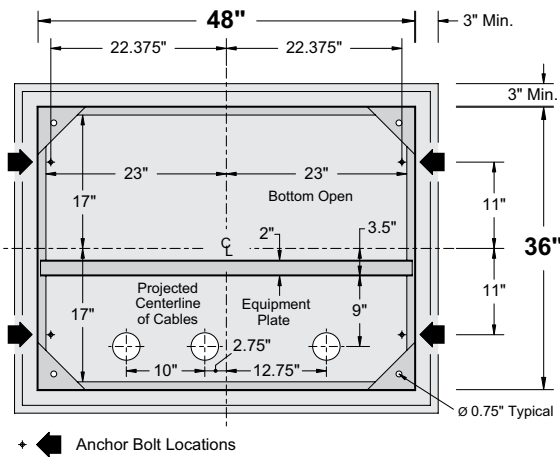
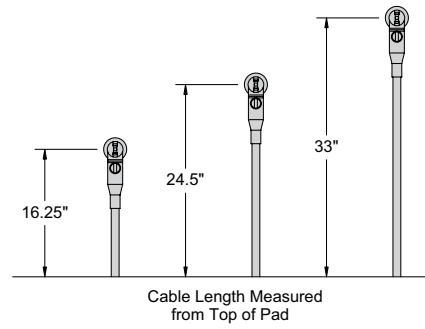

Alternate #1

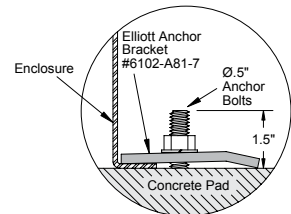

Alternate #2

Catalog Number	Fuse Mounting	Dimensions
EPMR-15-321S-E2-CM5	8.3 kV (Code 5) 1.5 to 140 Amp Clip Mounted Current-Limiting Fuse	Dimensions are listed above
EPMR-15-321S-E2-CM6	15.5 kV (Code 6) 1.5 to 125 Amp Clip Mounted Current-Limiting Fuse	Contact our Representative or the Factory for drawings

When additional cable terminating space is required, a 48" or 54" high enclosure can be supplied to increase cable terminating space by 6" or 12". To order a 48" high enclosure, suffix the catalog number "-48H". To order a 54" high enclosure, suffix the catalog number "-54H".

NX®, Arc-Strangler® and X-Limiter™ are either registered trademarks or trademarks of Eaton in the U.S. and other countries. Elastimold® is a registered trademark of ABB Asea Brown Boveri Ltd.

15-kV Safefront Mini-Switch Source Isolated Pad-Mounted Switchgear

140 Amp (Max) Clip-Mounted Current-Limiting Fuses

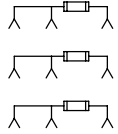

Three-Phase – Three Ways Per Phase

200 Amp Elliott Air-Insulated Bushing Wells
8.3/14.4 kV Grounded Wye Max Design
95 kV BIL

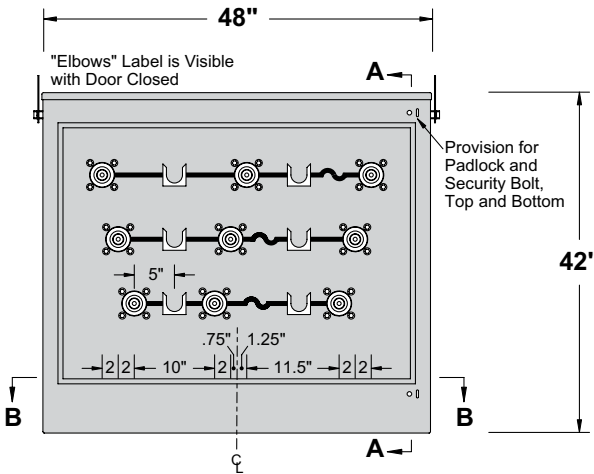

Front View
Door Removed

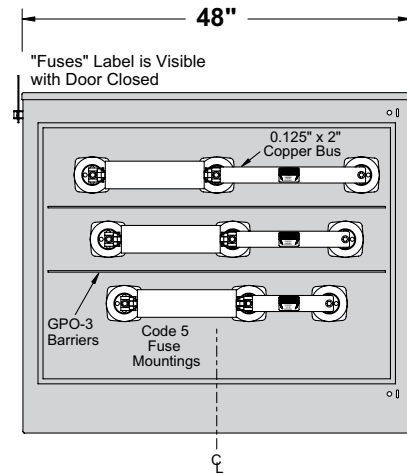

Rear View
Door & Door Safety Barrier Removed

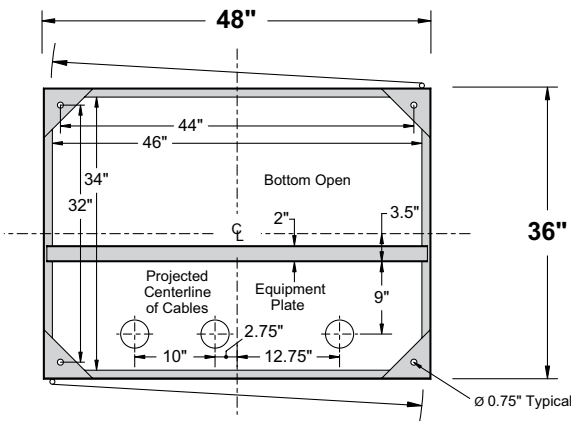

Section BB

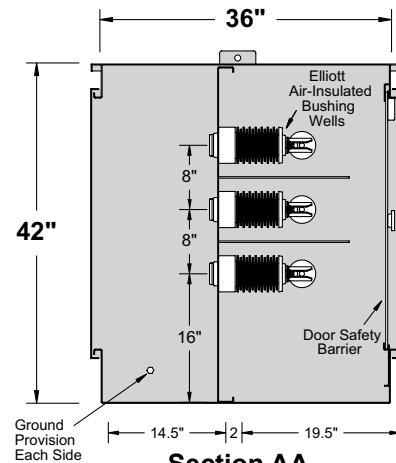

Section AA

Catalog Number	Fuse Mounting	Dimensions
EPMR-15-321S-E2-CM5	8.3 kV (Code 5) 1.5 to 140 Amp Clip Mounted Current-Limiting Fuse	Dimensions are listed above
EPMR-15-321S-E2-CM6	15.5 kV (Code 6) 1.5 to 125 Amp Clip Mounted Current-Limiting Fuse	Contact our Representative or the Factory for drawings

When additional cable terminating space is required, a 48" or 54" high enclosure can be supplied to increase cable terminating space by 6" or 12". To order a 48" high enclosure, suffix the catalog number "-48H". To order a 54" high enclosure, suffix the catalog number "-54H".



15-kV Safefront Mini-Switch Source Isolated Pad-Mounted Switchgear

140 Amp (Max) Clip-Mounted Current-Limiting Fuses

Bulletin
400-110
Page 8 2018

Cable Training and Anchor Bolt Locations

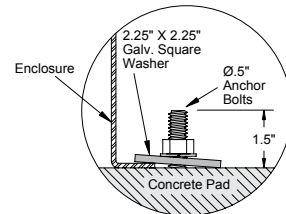
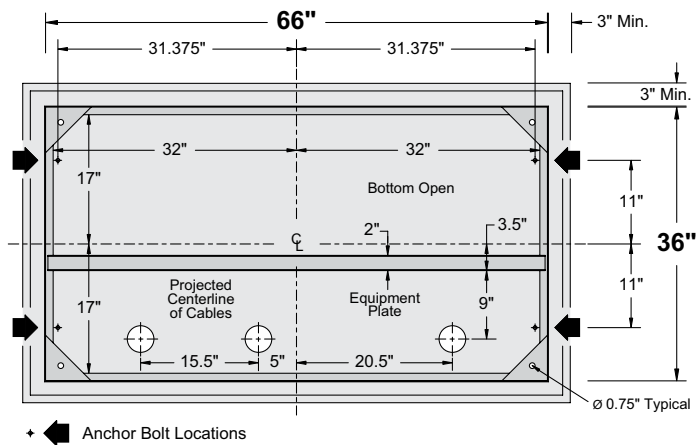
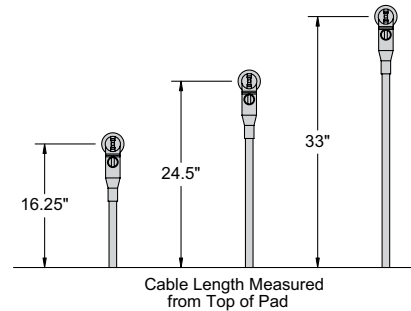
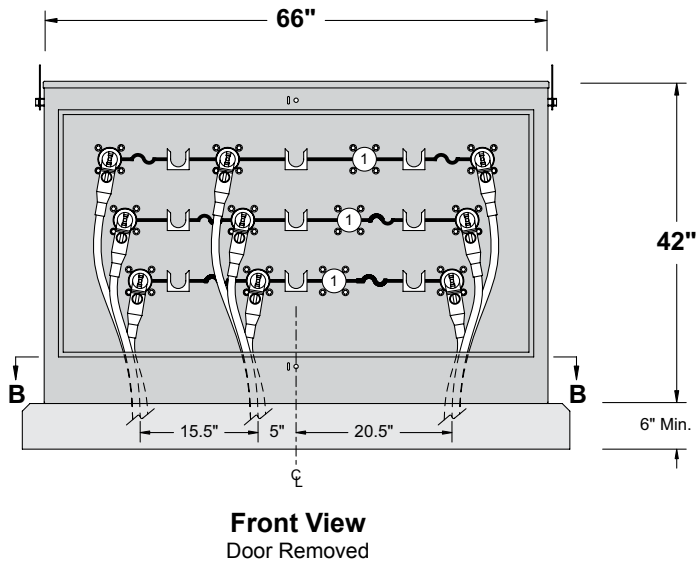

Alternate #1

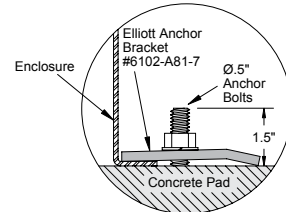

Alternate #2

① Bushing wells may be added if circuit requirements change - see page 15 in this bulletin.

Catalog Number	Fuse Mounting	Dimensions
EPMR-15-312S-E2-CM5	8.3 kV (Code 5) 1.5 to 140 Amp Clip Mounted Current-Limiting Fuse	Dimensions are listed above
EPMR-15-312S-E2-CM6	15.5 kV (Code 6) 1.5 to 125 Amp Clip Mounted Current-Limiting Fuse	Contact our Representative or the Factory for drawings

When additional cable terminating space is required, a 48" or 54" high enclosure can be supplied to increase cable terminating space by 6" or 12". To order a 48" high enclosure, suffix the catalog number "-48H". To order a 54" high enclosure, suffix the catalog number "-54H".

15-kV Safefront Mini-Switch Source Isolated Pad-Mounted Switchgear

140 Amp (Max) Clip-Mounted Current-Limiting Fuses

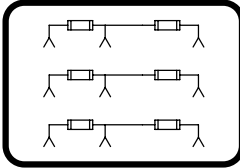

Three-Phase – Three Ways Per Phase

200 Amp Elliott Air-Insulated Bushing Wells
8.3/14.4 kV Grounded Wye Max Design
95 kV BIL

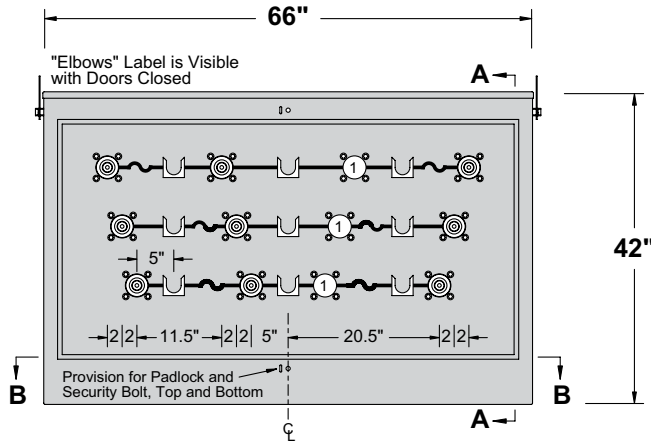

Front View
Door Removed

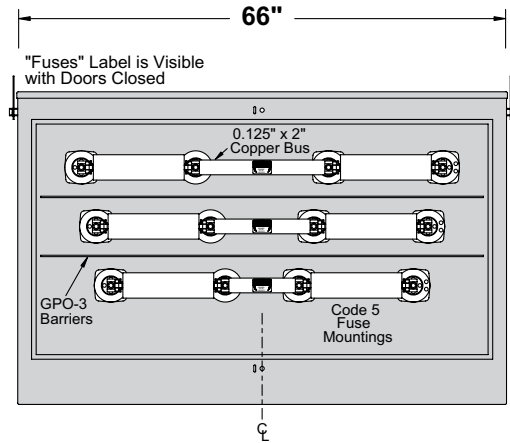

Rear View
Door & Door Safety
Barrier Removed

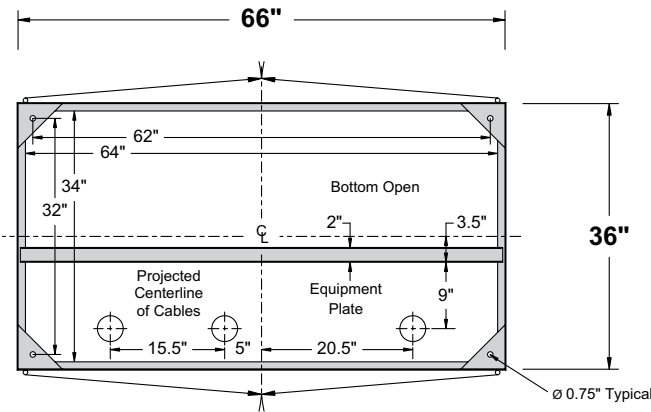

Section BB

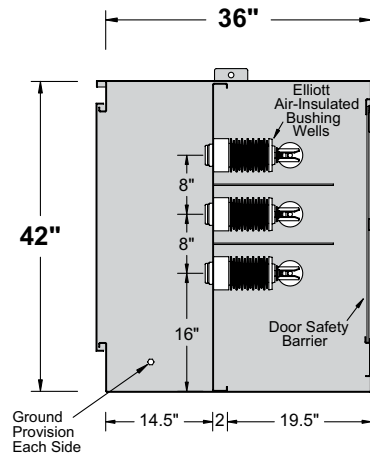

Section AA

① Bushing wells may be added if circuit requirements change - see page 15 in this bulletin.

Catalog Number	Fuse Mounting	Dimensions
EPMR-15-312S-E2-CM5	8.3 kV (Code 5) 1.5 to 140 Amp Clip Mounted Current-Limiting Fuse	Dimensions are listed above
EPMR-15-312S-E2-CM6	15.5 kV (Code 6) 1.5 to 125 Amp Clip Mounted Current-Limiting Fuse	Contact our Representative or the Factory for drawings

When additional cable terminating space is required, a 48" or 54" high enclosure can be supplied to increase cable terminating space by 6" or 12". To order a 48" high enclosure, suffix the catalog number "-48H". To order a 54" high enclosure, suffix the catalog number "-54H".

Cable Training and Anchor Bolt Locations

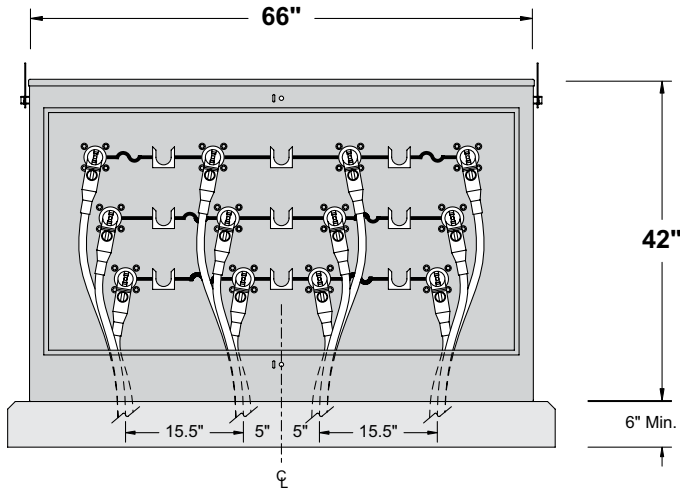

Front View
Door Removed

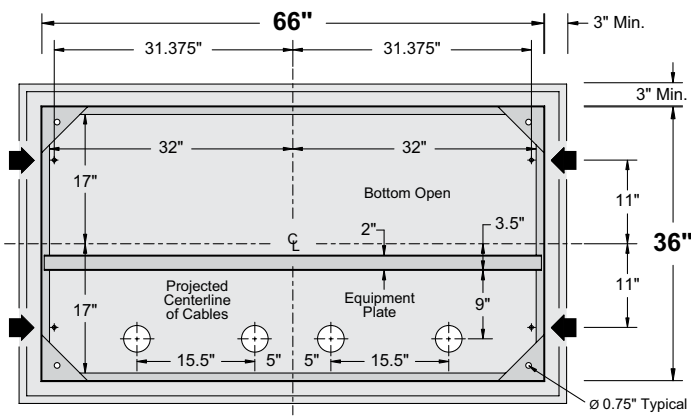
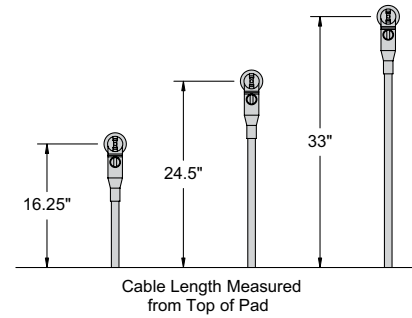

Section BB
and Typical Pad Dimensions

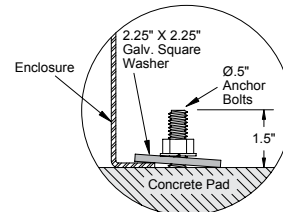

Alternate #1

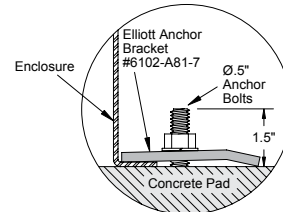

Alternate #2

Catalog Number	Fuse Mounting	Dimensions
EPMR-15-322S-E2-CM5	8.3 kV (Code 5) 1.5 to 140 Amp Clip Mounted Current-Limiting Fuse	Dimensions are listed above
EPMR-15-322S-E2-CM6	15.5 kV (Code 6) 1.5 to 125 Amp Clip Mounted Current-Limiting Fuse	Contact our Representative or the Factory for drawings

When additional cable terminating space is required, a 48" or 54" high enclosure can be supplied to increase cable terminating space by 6" or 12". To order a 48" high enclosure, suffix the catalog number "-48H". To order a 54" high enclosure, suffix the catalog number "-54H".

15-kV Safefront Mini-Switch Source Isolated Pad-Mounted Switchgear

140 Amp (Max) Clip-Mounted Current-Limiting Fuses

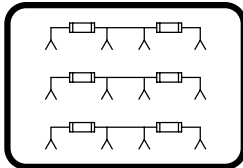

Three-Phase – Four Ways Per Phase

200 Amp Elliott Air-Insulated Bushing Wells
8.3/14.4 kV Grounded Wye Max Design
95 kV BIL

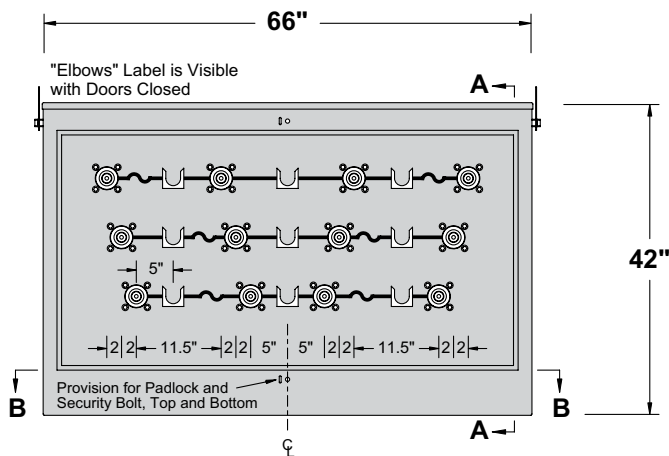

Front View
Door Removed

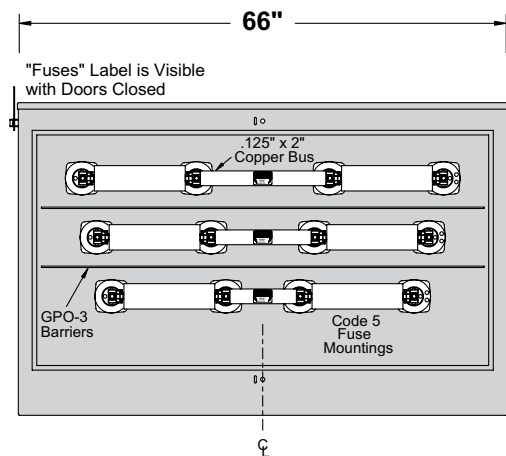

Rear View
Door & Door Safety Barrier Removed

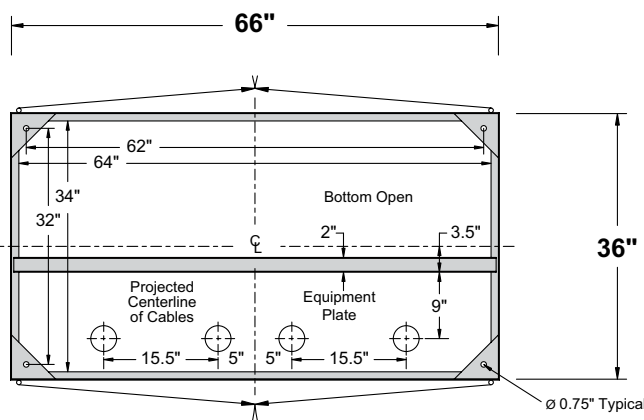

Section BB

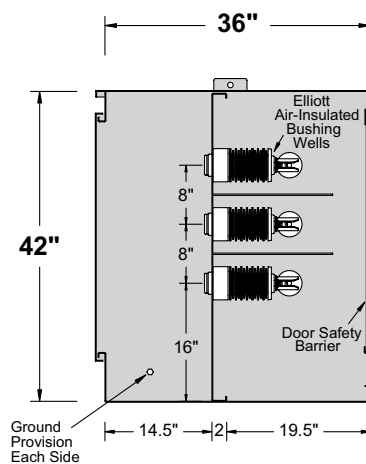

Section AA

Catalog Number	Fuse Mounting	Dimensions
EPMR-15-322S-E2-CM5	8.3 kV (Code 5) 1.5 to 140 Amp Clip Mounted Current-Limiting Fuse	Dimensions are listed above
EPMR-15-322S-E2-CM6	15.5 kV (Code 6) 1.5 to 125 Amp Clip Mounted Current-Limiting Fuse	Contact our Representative or the Factory for drawings

When additional cable terminating space is required, a 48" or 54" high enclosure can be supplied to increase cable terminating space by 6" or 12". To order a 48" high enclosure, suffix the catalog number "-48H". To order a 54" high enclosure, suffix the catalog number "-54H".

Typical Specification - Page 1 of 3

General

The switchgear shall be 15 kV class, 95 kV BIL, 200 ampere continuous current, suitable for use on 8.3/14.4 kV grounded wye max design systems. The switchgear shall be constructed for connection to the utility system with separable insulated connectors as described in IEEE Standard 386—latest revision (separable insulated connectors and loadbreak inserts shall be supplied by the user). The switchgear shall be designed for and contain fuse mountings in a compartment separated from the elbow compartment by a steel equipment plate. Separate access shall be provided for each compartment. A door safety barrier shall be provided inside the door(s) on the fuse compartment as recommended in IEEE Standard C2 (National Electrical Safety Code) Rule 381G. Tamper resistance shall meet the Enclosure Security requirements of IEEE Standard C57.12.28 (Pad-Mounted Equipment—Enclosure Integrity). Together, the tamper resistance and the door safety barrier shall resist unauthorized entry, protect authorized and unauthorized persons, and provide positive safety features when installed in areas accessible to the general public. The switchgear shall be constructed for outdoor installation in areas subject to heavy precipitation and in areas with windblown contamination. The equipment shall be “air-insulated” and completely assembled prior to shipment.

Enclosure Construction

The enclosure shall be tamper-resistant, all-welded construction utilizing 11-gauge minimum sheet steel. Corner plates and braces shall be used as necessary to assure rigidity. The enclosure top shall be cross-kinked to provide watershed and rigidity. The enclosure shall be open bottom with a 1-inch flange inside, all around. Separate compartments shall be provided for cable termination and for fuse mountings—each compartment equipped with its own individual access door(s) furnished with a stainless steel door holder that will latch the door open 100 degrees and 140 degrees and resist accidental closing. The equipment plate separating the two compartments shall be full length, constructed with 11-gauge minimum sheet steel braced to assure rigidity when operating the elbows and fuses. Doors shall be provided with provisions for padlocking and a recessed penta-head (or hex-head) security bolt to prevent unauthorized entry (coordinated to prevent installation of the padlock until the security bolt is tightened *when closing the door(s)* and to prevent a wrench from operating the security bolt until the padlock is removed *when opening the door(s)*). The security bolt shall be made captive with a stainless steel washer compressed to an oval shape to severely discourage removal. Hinges shall be stainless steel (with stainless steel pins not less than 0.3125-inch diameter) and shall be welded to both the enclosure and the door(s) to maintain door alignment for the life of the equipment. The

enclosure shall be nonventilated to minimize the entrance of airborne contamination, insects, rodents or reptiles. The protective finish shall include necessary grinding, cleaning and phosphating, two-component rust-inhibiting epoxy primer and a Pad-Mount Green two-component polyurethane top coat finish (Munsell color 7GY 3.29/1.5). The primer and top coat shall be electronically monitored during application to insure proper ratio and mixing of each component. Total average thickness of paint (after curing) shall be not less than 5 mils. The protective coating shall meet the Enclosure Coating System requirements of IEEE Standard C57.12.28 (Pad-Mounted Equipment—Enclosure Integrity). Removable lift provisions, adequate to withstand handling with normal utility equipment, shall be provided on the outside of the enclosure. Threaded openings for lift provision bolts shall be blind holes to prevent the entrance of wire or other foreign objects into the enclosure when lift provisions are removed.

Bushings and Terminals

Bushings shall be 200 ampere Elliott #1101-225B, 25 kV class (15.2 kV to ground) Air-Insulated Bushing Wells, 125 kV BIL, per IEEE Standard 386-2016 Fig. 3 (Interface 3: a 200 A Bushing Well Interface) *for use with either 8.3/14.4 kV or 15.2/26.3 kV separable insulated connectors* (Elastimold®, Eaton's Cooper Power Systems or other approved equal). The bushing wells shall be pressure-molded cycloaliphatic epoxy with a 0.75-inch diameter copper conductor on the “air-insulated” side that is drilled and tapped 0.375-inch – 16UNC x 1-inch deep to provide direct connection of the bus and/or live parts. Leakage distance from the apparatus connection end of the bushing well to ground shall be not less than 30 inches to assure trouble-free operation in a wet and/or contaminated environment. Integral shielding shall be provided to eliminate partial discharge caused by off-center mounting and mounting holes that may have sharp edges or burrs. Bushing wells shall mount in a 3.125-inch diameter opening and bolt in place to allow field replacement with standard tools. The bushing well mounting bolts shall be self-locking stainless steel serrated-flange hex-head bolts that “cut” through the enclosure protective finish to ground the integral shielding of each bushing well. The head of one or more of the mounting bolts for each bushing well shall include a 0.156-inch diameter hole to provide a connection to ground for the loadbreak insert shielding ground wire as recommended by separable insulated connector manufacturers. To assure adequate strength for apparatus support, the bushing well shall withstand a minimum cantilever loading of 600 pounds for five minutes without damage. The bushing well interface shall be free of all voids, holes and heat sinks to assure proper mating with separable insulated connectors. Each bushing well shall be tested in free air, mounted in a grounded steel plate not less

Typical Specification - Page 2 of 3

than 10 inches x 10 inches, with a bushing well plug (Eaton's Cooper Power Systems #IBWP225 or equal) installed in the well interface to accurately simulate operating conditions (*gas or liquid dielectric in the interface shall not be acceptable for this test*). Each bushing well shall meet the requirements for 25 kV devices in accordance with IEEE Standard 386 (latest revision), including 100 percent production testing.

Bus and Fuse Mountings

Bus shall be copper with all burrs and sharp corners removed prior to installation. Fuse clips shall be keyed to prevent rotation and to maintain alignment. Positive pressure shall be assured by use of stainless steel fasteners and lock washers or compression washers at all connection points. All connections shall provide direct contact of current-carrying parts and shall not depend on current transfer through fastener thread-to-thread contact. The bus shall be arranged to allow inspection and tightening of all connections (with standard hand tools) without the necessity of removing phase barriers, ground barriers or fuse mountings. Fuses and their blown-fuse indicators shall be visible (*when the fuse compartment door(s) are open*) without removal of the clear-polycarbonate door safety barrier to allow easy identification of blown fuses without de-energizing or removing the fuse from service. Electrical components shall be "air-insulated" and positioned to allow visual inspection of all internal connections and components *without removing the clear-polycarbonate door safety barrier*, de-energizing or removing the equipment from service.

Alternate 1: Fuse mountings shall be Mounting Code 5 to accept 1.5 amp to 100 amp (max), 8.3 kV Eaton's Cooper Power Systems NX® and 6 amp to 140 amp (max), 8.3 kV Eaton's Cooper Power Systems X-Limiter™ clip-mounted current-limiting fuses. *When 1.5 amp to 40 amp 8.3 kV Code 4 fuses are supplied, one Elliott Industries #3901-CM4-5 fuse extender per fuse shall be supplied to extend the Code 4 fuse length to fit Mounting Code 5 fuse mountings.* A Warning Sign, Elliott #7201-W2003-318, shall be provided inside the fuse compartment door(s) to warn the operator to "Park the load side cable before installing or removing fuses." A Danger Sign, Elliott #7203-D2003-313, shall be provided in a prominent location near the fuse clips to warn the operator "Do not remove fuse under load." Spare-fuse storage is optional. When specified, a spare-fuse holder shall be provided that will allow storage (and retrieval) of Code 4 or Code 5 fuses with hot-line tools. Spare-fuse storage shall not interfere with opening or closing the doors.

Alternate 2: Fuse mountings shall be Mounting Code 6 to accept 1.5 amp to 100 amp (max), 15.5 kV Eaton's Cooper Power Systems NX® and 6 amp to 125 amp (max), 15.5 kV Eaton's Cooper Power Systems X-Limiter™ clip-mounted current-limiting fuses. *When 1.5 amp to 40 amp*

15.5 kV Code 5 fuses are supplied, one Elliott Industries #3901-CM5-6 fuse extender per fuse shall be supplied to extend the Code 5 fuse length to fit Mounting Code 6 fuse mountings. A Warning Sign, Elliott #7201-W2003-318, shall be provided inside the fuse compartment door(s) to warn the operator to "Park the load side cable before installing or removing fuses." A Danger Sign, Elliott #7203-D2003-313, shall be provided in a prominent location near the fuse clips to warn the operator "Do not remove fuse under load." Spare-fuse storage is optional. When specified, a spare-fuse holder shall be provided that will allow storage (and retrieval) of Code 5 or Code 6 fuses with hot-line tools. Spare-fuse storage shall not interfere with opening or closing the doors.

Barriers

Phase and ground barriers shall be provided to assure correct phase-to-phase and phase-to-ground clearances for proper operation at rated voltage. These barriers shall be glass-reinforced polyester (NEMA GPO-3 class material) not less than 0.1875-inch thick.

A removable insulating barrier with a "DANGER – Keep Out! – Hazardous voltage" sign, Elliott #7203-D2003-309, shall be located inside the door(s) on the fuse compartment as recommended in Rule 381G of IEEE Standard C2 (National Electrical Safety Code). This door safety barrier shall be constructed of 0.25-inch clear polycarbonate (Lexan or equal) and shall completely close the door opening and be provided with a nonconductive safety latch requiring a positive action to remove the barrier. Handles and other hardware extending through this door safety barrier shall be nonconductive material. Handles shall be keyed to prevent rotation for secure handling. Complete visual inspection of the internal components shall be possible without removing the door safety barrier.

Grounding Provisions

Two high-conductivity bronze eyebolt-type ground lugs, which accept #6 through #2/0 copper conductor, shall be installed in the cable terminating compartment (located on each side of the door opening in an accessible position).

Accessory Equipment

Stainless steel parking stands shall be provided in the quantity required to allow use of feed-thru bushings, parking bushings and grounding bushings. The parking stands shall be welded in place, in a position to allow the use of hot-line tools for installation of feed-thru bushings, etc. The parking stands shall be *unpainted* (except welds shall be painted) to provide a ground for feed-thru bushings and other devices that may be placed into the parking stands.

A corrosion proof nameplate with permanent thermal transfer printing shall be installed inside one door on the elbow

Typical Specification - Page 3 of 3

compartment. It shall be located at the top corner farthest from the elbows when the door is open. The nameplate will provide Type of Equipment, Model Number, Amps Continuous, kV Maximum, BIL, Serial Number, Job Number, Date Manufactured and Weight of Equipment.

Bus and fuse connections between bushings shall be displayed (on the cable side of the equipment plate) using 0.5-inch-wide solid orange-color pressure-sensitive vinyl tape and die-cut orange-color pressure-sensitive vinyl fuse symbols not less than 2.5 inches high. The resulting schematic shall clearly indicate the circuit arrangement of the switchgear. The schematic shall be legible at a distance of six feet or more.

When enclosures have more than one door (or other access provision) each access shall be labeled in near proximity of the locking provisions with a pressure-sensitive vinyl label using letters not less than 0.375-inch nor more than 0.625-inch high. The label shall indicate the type of equipment behind the access (elbows, fuses, bus, etc.).

When specified, four anchor-bolt brackets, Elliott #6102-A81-7 or approved equal, shall be supplied with each

switchgear to provide a means of clamping the equipment to the concrete pad.

Packaging

Each switchgear shall be bolted to a solid-top wood pallet (to prevent the forks of a forklift truck from entering the open bottom of the equipment) to prevent hidden damage. The equipment shall be wrapped with 0.125-inch thick polyethylene foam or other suitable material to minimize damage to the finish during shipment.

Drawings

When specified, drawings shall be furnished for each switchgear that include:

- 1) enclosure dimensions and location of components.
- 2) proposed cable training layout and dimensions.
- 3) proposed pad dimensions and location of anchor bolts.

200 Amp Bushing Well #1101-225B

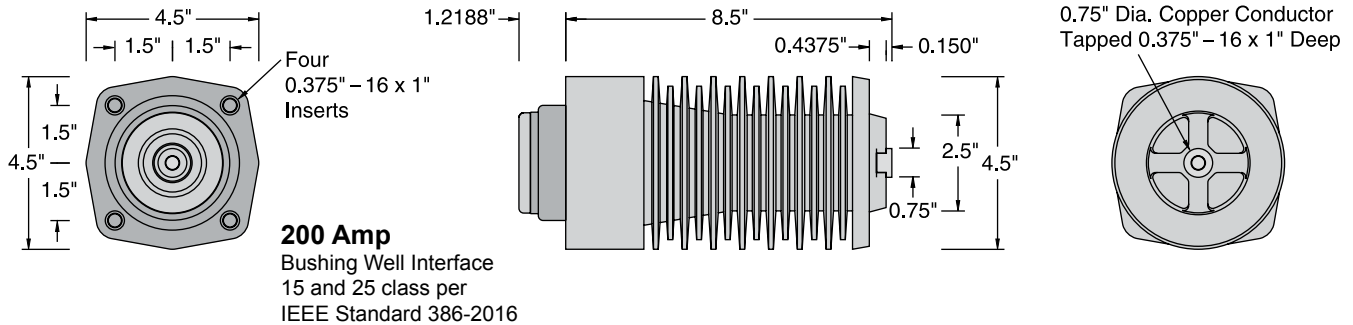

Voltage Class.....	25 kV
Phase to Ground Voltage.....	15.2 kV
BIL.....	125 kV
AC Withstand - 1 Min. Dry.....	40 kV
10 Sec. Dew.....	40 kV
DC Withstand - 15 Min. Dry.....	78 kV
Corona Extinction Level - Minimum.....	19 kV
Continuous Current.....	200 Amps
Momentary - RMS, Sym., 0.17 sec.....	10,000 Amps
RMS, Sym., 3 sec.....	3,500 Amps

Leakage Distance, Inches.....	34
Dry Arcing Distance, Inches.....	8.5
Mechanical - Strength Rating, Pounds	
Cantilever, Ultimate 2.5 inches past end.....	>1,000
Tensile, Pounds.....	>5,000
Torsion, Inch Pounds (Bolt Breaks).....	>700
Compression, Pounds.....	20,000
Insert Thread Size.....	0.375"-16 x 1"
Conductor (Live End) Thread Size.....	0.375"-16 x 1"
Net Weight, Pounds.....	6.75

Bushing Well Installation Instructions

The #EPMR-15-312S-E2-CM5 and #EPMR-15-312S-E2-CM6 three-phase Safefront Mini-Switches have equipment plates punched to accept twelve bushing wells. The extra mounting holes are closed with insulator bushings. If circuit arrangements change, bushing wells can be added to provide the #EPMR-15-322S-E2-CM5 and #EPMR-15-322S-E2-CM6 circuit arrangement shown on pages 10 and 11 in this bulletin.

The mounting hardware used to mount the insulator bushing is the same hardware used to install a bushing well. There is no need to drill holes when modification is required.

NOTE: *The mini-switch must be de-energized and grounded in accordance with your company's normal safety procedure before any modifications are made.*

Procedure for Bushing Well Installation

NOTE: *The shipping cap on the bushing well should be left in place to prevent contamination of the interface.*

1. Remove the fuse(s).
2. Remove the bus bar.
3. Remove the insulator assembly from the equipment plate (retain for future use).
4. Install the bushing well into the mounting hole from the fuse side.
5. Install serrated flange bolts. Bolts should be tightened in a uniform manner applying no more than 90 inch lbs. torque to each bolt. The serration must "cut" into the mounting plate to provide a connection from the shielding to the grounded equipment mounting plate.
6. Connect the copper bus bar and fuse clip to the bushing just installed using hardware previously removed.
7. Tighten the bolt on both ends of the bus bar no more than 200 inch lbs.

IMPORTANT: *Do not energize this bushing well with only the shipping cap in place.* To do so would lead to failure of this bushing and create a hazard to operating personnel. *This product is designed to be used only when it is mated with an appropriate 15 kV or 25 kV class bushing insert (or elbow) conforming to the latest revision of IEEE Standard 386.* The bushing insert (or elbow) should be installed in accordance with the instructions supplied by the insert manufacturer.

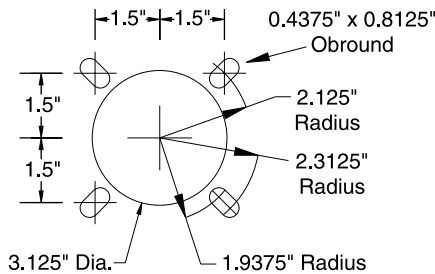

Uni-Mount Mounting Holes

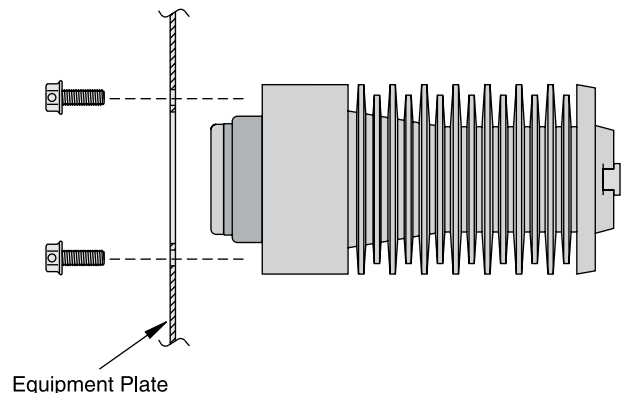

Fuse Selection Information

**NX® Current-Limiting Fuses
Clip Mounted Style**

50,000 amps Symmetrical Interrupting Rating			
Rating		Mounting ^① Code Number*	Catalog Number
Voltage (kV)	Continuous Current (amp)		
For Single and Parallel Unit Clip Style Mountings			
8.3	1.5	4	FA3H1
	3	4	FA3H3
	4.5	4	FA3H4
	6	4	FA3H6
	8	4	FA3H8
	10	4	FA3H10
	12	4	FA3H12
	18	4	FA3H18
	20	4	FA3H20
	25	4	FA3H25
	30	4	FA3H30
	40	4	FA3H40
	50	5	FA3H50
	65	5	FA3H65
80	5	FA3H80	
100	5	FA3H100	
15.5	1.5	5	FA4H1
	3	5	FA4H3
	4.5	5	FA4H4
	6	5	FA4H6
	8	5	FA4H8
	10	5	FA4H10
	12	5	FA4H12
	18	5	FA4H18
	20	5	FA4H20
	25	5	FA4H25
	30	5	FA4H30
	40	5	FA4H40
	50	6	FA4H50
	65	6	FA4H65
80	6	FA4H80	
100	6	FA4H100 ^②	

②At present, 100 amp, 15.5 kV fuse is suitable for systems up to 13.5 kV maximum voltage rating.

Features

Silent - No gases are expelled because the arc is confined and cooled and the vapor quickly condensed by a sand filler.

Safe - No explosion or strong mechanical force is produced to damage surrounding equipment; no burning particles that might be a fire hazard.

Current-limiting - Fault current is held to a low value by a fulgurite produced by the fault current itself. *Fast, full-range clearing* from minimum melt to maximum fuse rating.

Blown-fuse indication - A red button in the end of the contact projects and is visible after the fuse has operated.

**X-Limiter™ Full Range Current-Limiting Fuses
Clip Mounted Style**

50,000 amps Symmetrical Interrupting Rating			
Rating		Mounting ^① Code Number*	Catalog Number
Voltage (kV)	Continuous Current (amp)		
For Single and Parallel Unit Clip Style Mountings			
8.3	06	4	83F06-I/I
	08	4	83F08-I/I
	10	4	83F10-I/I
	12	4	83F12-I/I
	18	4	83F18-I/I
	20	4	83F20-I/I
	25	4	83F25-I/I
	30	4	83F30-I/I
	40	4	83F40-I/I
	50	5	83F50-I/I
	65	5	83F65-I/I
	80	5	83F80-I/I
	100	5	83F100-I/I
	125	5	83F125-I/I
140	5	83F140-I/I	
15.5	06	5	155F06-I/I
	08	5	155F08-I/I
	10	5	155F10-I/I
	12	5	155F12-I/I
	18	5	155F18-I/I
	20	5	155F20-I/I
	25	5	155F25-I/I
	30	5	155F30-I/I
	40	5	155F40-I/I
	50	6	155F50-I/I
	65	6	155F65-I/I
	80	6	155F80-I/I
	100	6	155F100-I/I
	125	6	155F125-I/I

*Code number of mounting must match code number of fuse or switchblade.

①Fuse extenders must be used to extend 1.5 to 40 amp fuses so they fit the 140 amp or 125 amp fuse mountings in Elliott Safefront Mini-Switches.

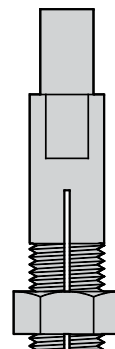

Catalog No. 3901-	Extends Fuse Code	To Fit Mfg. Code
CM4-5	4	5
CM5-6	5	6
CM4-6	4	6

For other combinations see Bulletin 3901

Installation is easy using two adjustable wrenches. The fuse extender is pushed onto the top contact of the fuse and the compression nut is tightened. To remove the extender, loosen the compression nut and pull the extender off.