

**25-kV Safefront Mini-Switch
Phase Isolated Pad-Mounted Switchgear**
125 Amp (Max) Clip-Mounted Current-Limiting Fuses

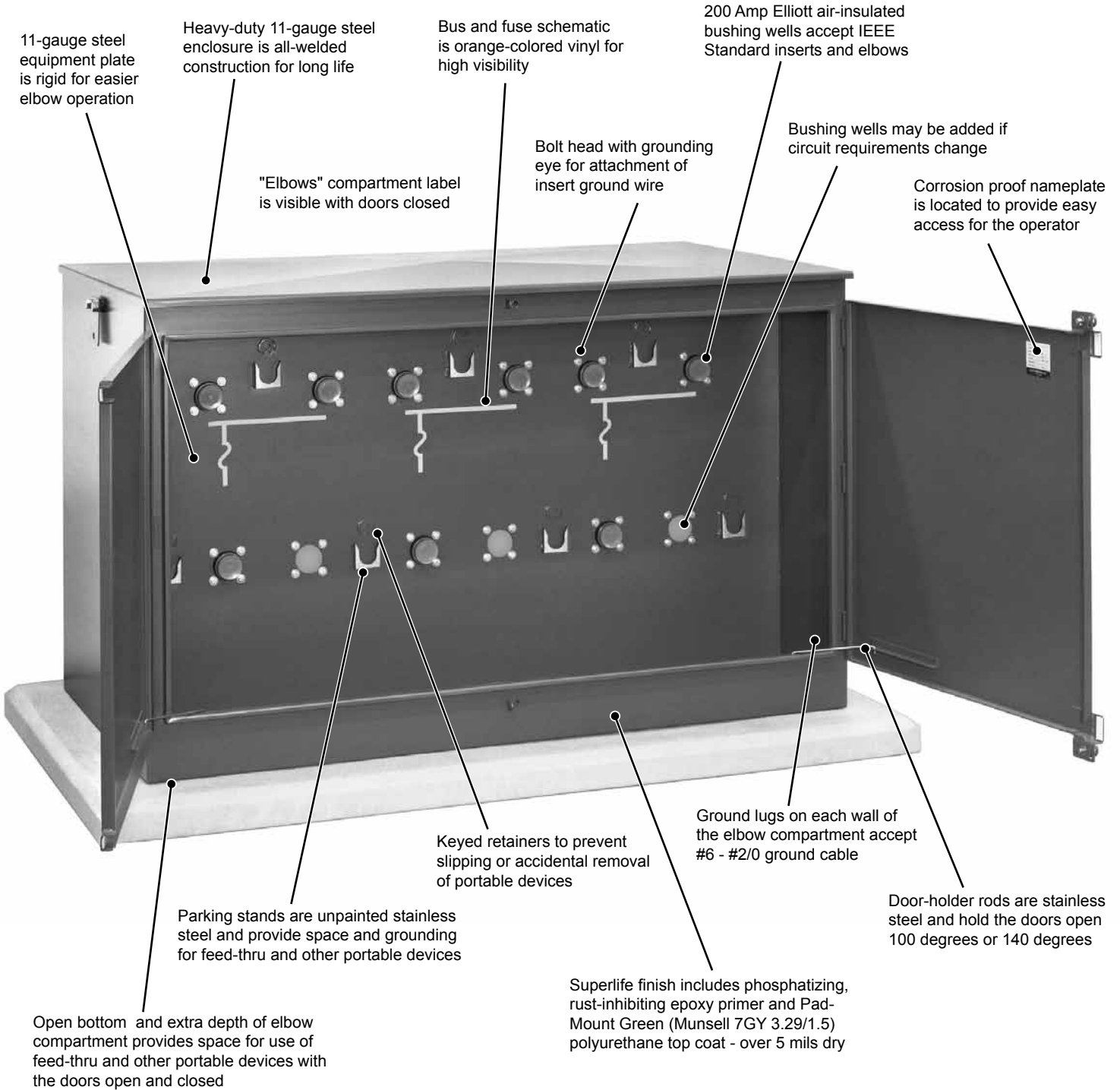

ENCLOSURE OPTIONS:

- 1) 0.125" #5052H32 Aluminum
- 2) 12-gauge #304L Stainless Steel

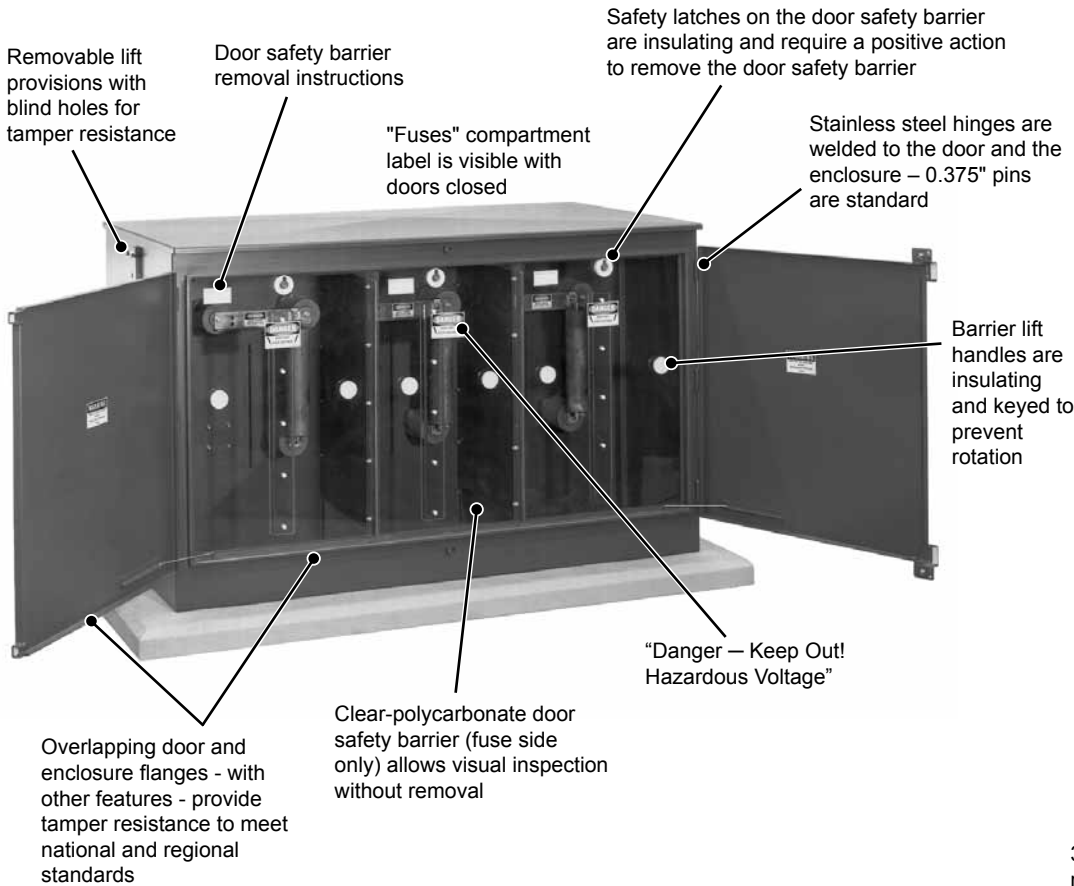

Field-Proven Components including Elliott bushing wells specifically designed for "in-air" operation gives you long-term reliable service

Standard Cable Training means quick, economical installation and assures proper operation for the life of the equipment

Deep Elbow Compartment and careful placement of bushing wells and parking stands makes switching and grounding easier and safer

Tamper-Resistant Enclosure meets National and Regional Enclosure Integrity Standards and virtually eliminates the entrance of airborne contamination to reduce maintenance

"In-Air" Insulation eliminates leaking or contamination of insulating medium for long trouble-free operation

"In-Air" Visibility allows visual inspection of all components without the inconvenience or expense associated with equipment which must be de-energized for inspection

"In-Air" Accessibility means every connection may be checked and tightened using hot stick tools without de-energizing the equipment

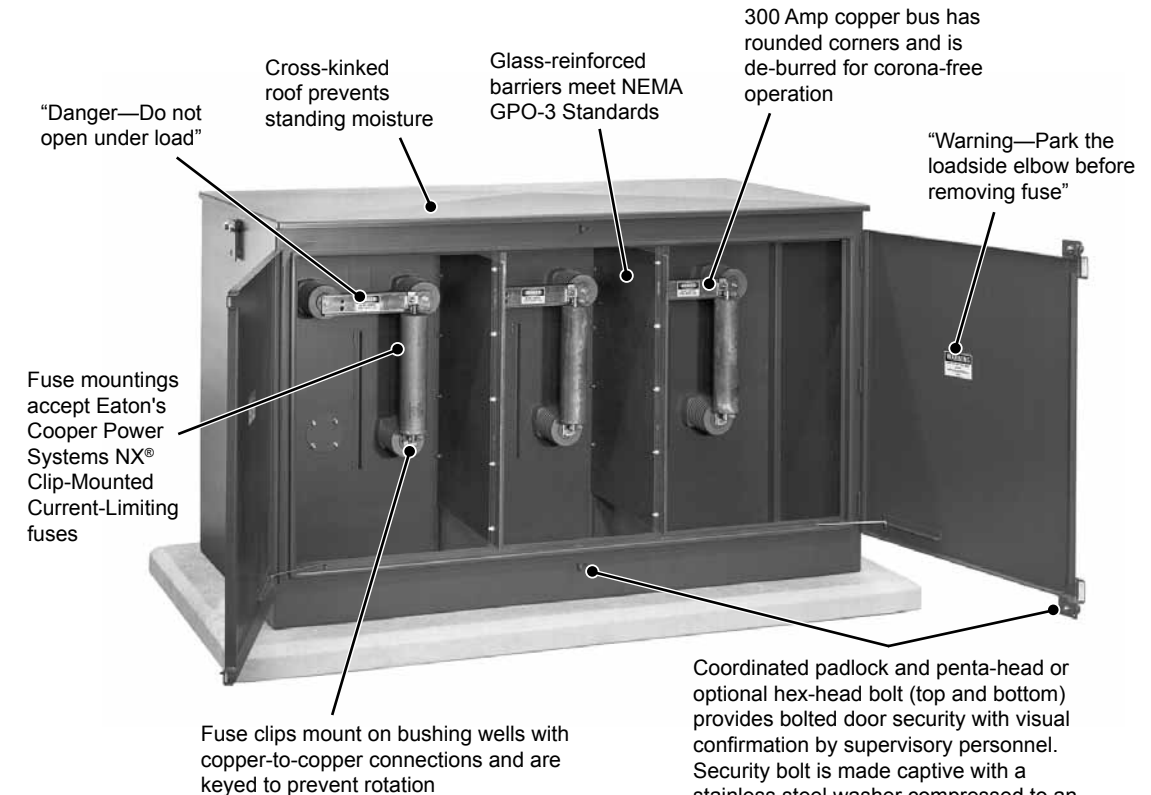

Standard Cable Training

The Safefront switchgear shown in this Bulletin was designed to employ the cable training shown in the single phase drawings below. Common bushing well locations provide the advantages of standard cable training for all circuits. Switchgear with one circuit arrangement can be replaced by switchgear with a different circuit arrangement and the existing cables need not be reterminated. The equipment plate of the single-phase mini-switch is punched to accept four bushing wells. The equipment plate of the three-phase mini-switch is punched to accept twelve bushing wells. Adapter plates cover the mounting holes not in use. Bushing wells can be added or removed in the field using only standard tools. There is no need to drill holes when modification is required. Fuse barrier angles are provided in each design for installation of fuse barriers if circuit requirements ever change. Generous space is provided at every parking stand to allow use of a parking or feed-thru accessory. The upper parking stand is positioned above the bushing wells for easy transfer of elbows to a parking or feed-thru accessory and yet keep the cables clear of the lower bushing wells and parking stands when the upper elbows are in a parking or feed-thru accessory. Lower parking stands are positioned slightly below the bushing wells for easy transfer of elbows to a parking or feed-thru accessory.

Dimension drawings showing two phase designs are available upon request.

Safefront (elbow-terminated) switchgear is available for 200, 600, 900 and 1250 amperes and voltage ratings including 15 kV, 25 kV and 35 kV. If you do not find a model to fit your need, please contact our representative or the factory.

Selecting Switchgear

The switchgear shown in the circuit diagrams below is rated 15.2/26.3 kV Grounded Wye Maximum Design. Dimension drawings showing each single and three phase design can be found on pages 4 through 19 of this bulletin. The continuous-current rating of the bushing wells is 200 amperes with an eight-hour overload rating of 300 amperes.

Maximum fuse size is 100 amperes utilizing Eaton's Cooper Power Systems Clip-Mounted NX® full-range current-limiting fuses. Maximum fuse size is 125 amperes utilizing Eaton's Cooper Power Systems X-Limiter™ full-range current-limiting fuses. Each model can be ordered with or without the Clip-Mounted Fuses (fuse sizes and description are found on page 24 of this bulletin).

Elliott Air-Insulated Bushing Wells are designed for "in-air" operation and accept Elastimold®, Eaton's Cooper Power Systems and other 25 kV class IEEE Standard loadbreak bushing inserts and elbow terminators. When clip-mounted fuses are specified, all loadbreak or loadmake operations must be accomplished with the loadbreak elbow terminators. The continuous-current rating of the copper bus is 300 amperes. Two ground connectors which accept #6 through #2/0 cable, are included and are installed as shown by the drawings.

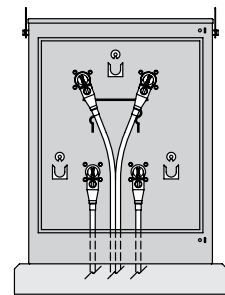
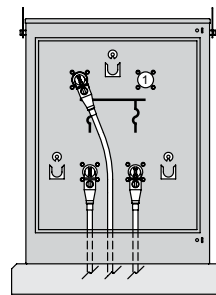
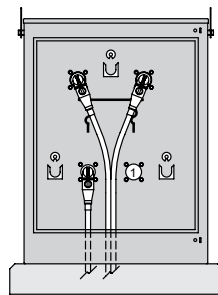
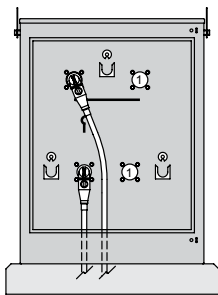

① Bushing wells may be added if circuit requirements change - see page 23 in this bulletin.

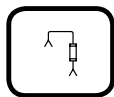

EPMR-25-111-E2-CM6

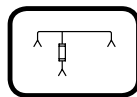

EPMR-25-121-E2-CM6

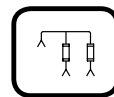

EPMR-25-112-E2-CM6

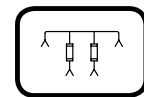

EPMR-25-122-E2-CM6

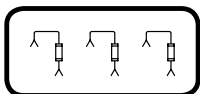

EPMR-25-311P-E2-CM6

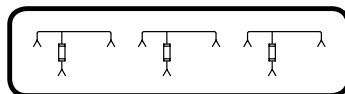

EPMR-25-321P-E2-CM6

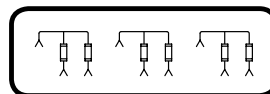

EPMR-25-312P-E2-CM6

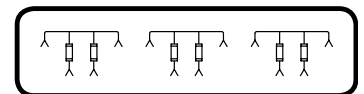

EPMR-25-322P-E2-CM6

Cable Training and Anchor Bolt Locations

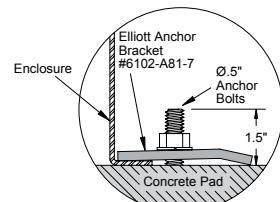
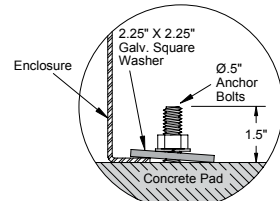
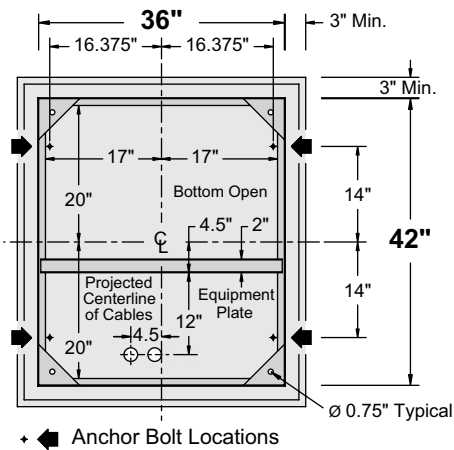
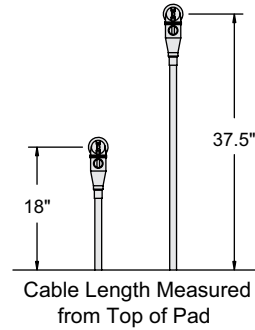
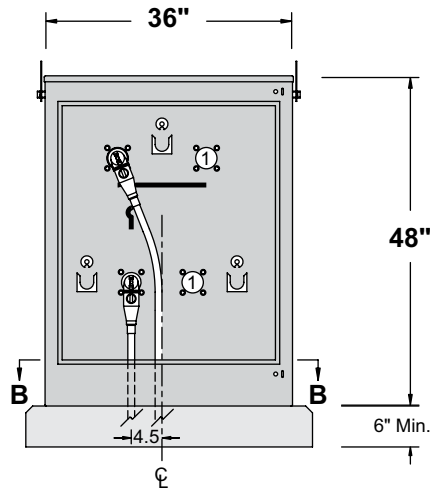

① Bushing wells may be added if circuit requirements change - see page 23 in this bulletin.

| | |
|-----------------------------|--|
| <h2>EPMR-25-111-E2-CM6</h2> | <p>15.5 kV (Code 6) 1.5 To 100 Amp NX® or 6 to 125 Amp X-Limiter™ Clip Mounted Fuse 23 kV (Code 6) 6 to 40 Amp Clip Mounted NX® or X-Limiter™ Fuse For parallel fuses see Note ② page 24</p> |
|-----------------------------|--|

When additional cable terminating space is required, a 54" high enclosure can be supplied to increase cable terminating space by 6". To order a 54" high enclosure, suffix the catalog number "-54H".

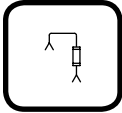

Single Phase – Two Ways Per Phase

200 Amp Elliott Air-Insulated Bushing Wells
15.2 kV Max Design
125 kV BIL

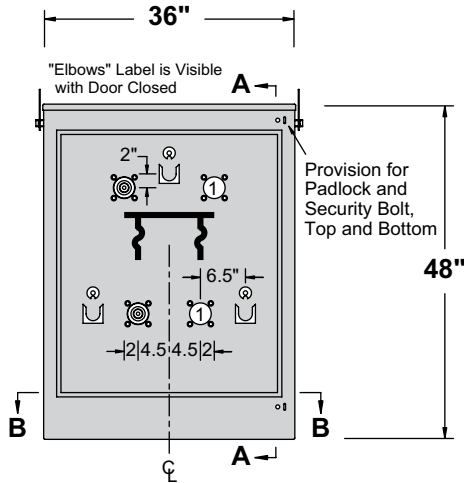

Front View
Door Removed

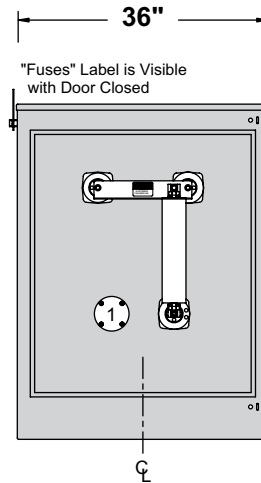

Rear View
Door & Door Safety
Barrier Removed

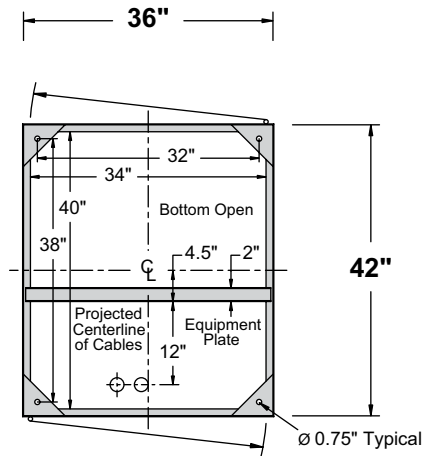

Section BB

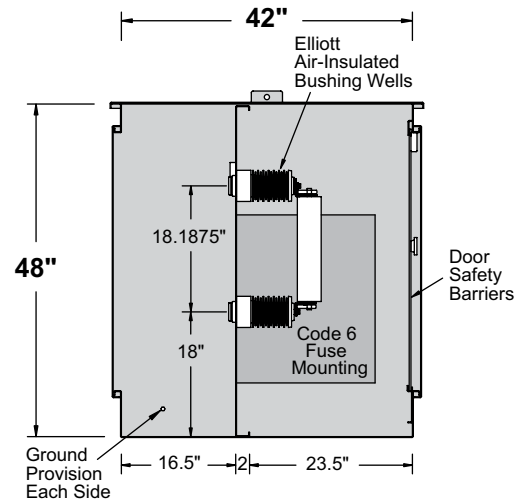

Section AA

① Bushing wells may be added if circuit requirements change - see page 23 in this bulletin.

EPMR-25-111-E2-CM6

15.5 kV (Code 6) 1.5 To 100 Amp NX® or
6 to 125 Amp X-Limiter™ Clip Mounted Fuse
23 kV (Code 6) 6 to 40 Amp
Clip Mounted NX® or X-Limiter™ Fuse
For parallel fuses see Note ② page 24

When additional cable terminating space is required, a 54" high enclosure can be supplied to increase cable terminating space by 6". To order a 54" high enclosure, suffix the catalog number "-54H".

Cable Training and Anchor Bolt Locations

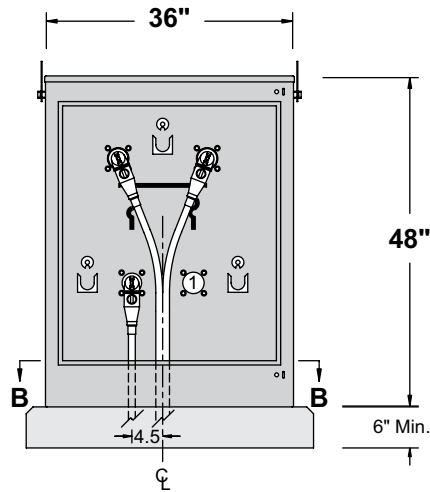

Front View
Door Removed

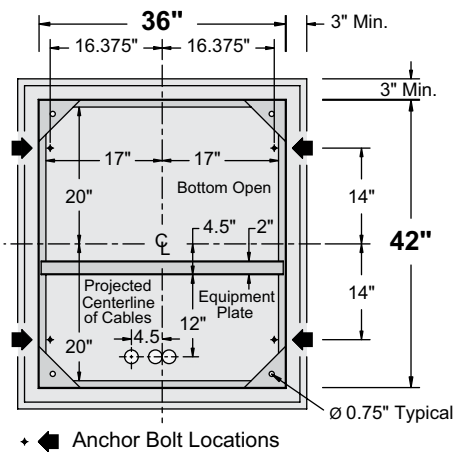
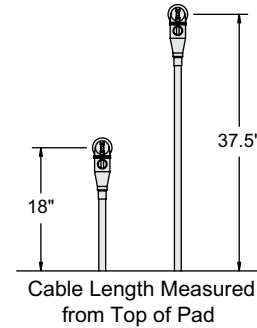

Section BB
and Typical Pad Dimensions

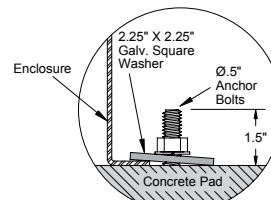

Alternate #1

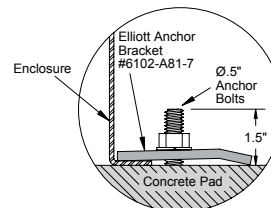

Alternate #2

① Bushing wells may be added if circuit requirements change - see page 23 in this bulletin.

EPMR-25-121-E2-CM6

15.5 kV (Code 6) 1.5 To 100 Amp NX® or
6 to 125 Amp X-Limiter™ Clip Mounted Fuse
23 kV (Code 6) 6 to 40 Amp
Clip Mounted NX® or X-Limiter™ Fuse
For parallel fuses see Note ② page 24

When additional cable terminating space is required, a 54" high enclosure can be supplied to increase cable terminating space by 6". To order a 54" high enclosure, suffix the catalog number "-54H".

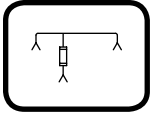

Single Phase – Three Ways Per Phase

200 Amp Elliott Air-Insulated Bushing Wells
15.2 kV Max Design
125 kV BIL

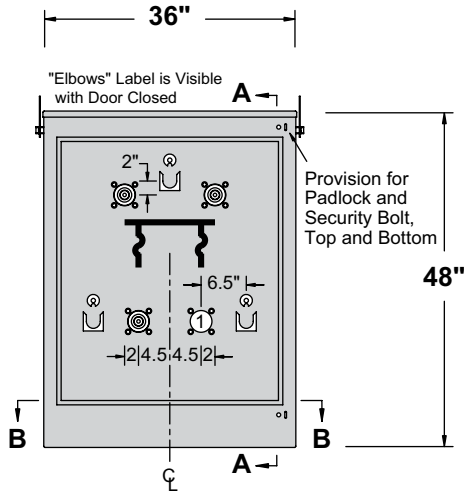

Front View
Door Removed

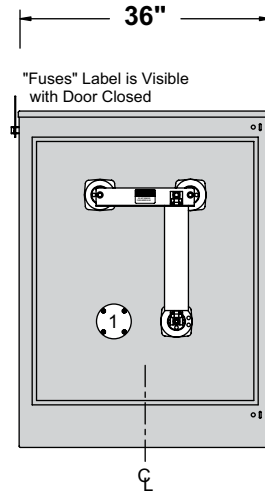

Rear View
Door & Door Safety
Barrier Removed

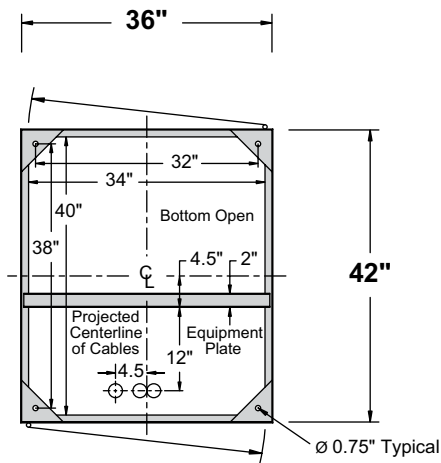

Section BB

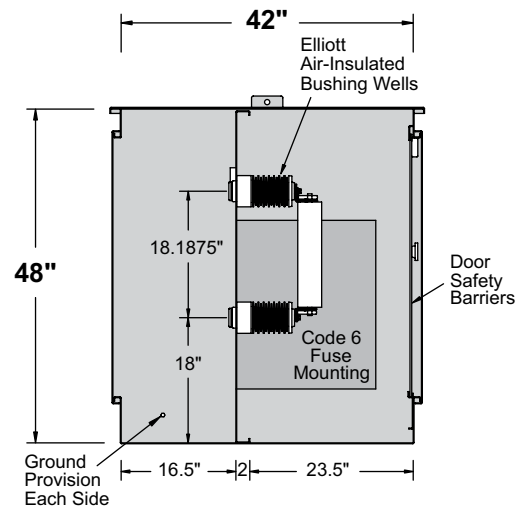

Section AA

① Bushing wells may be added if circuit requirements change - see page 23 in this bulletin.

EPMR-25-121-E2-CM6

15.5 kV (Code 6) 1.5 To 100 Amp NX® or
6 to 125 Amp X-Limiter™ Clip Mounted Fuse
23 kV (Code 6) 6 to 40 Amp
Clip Mounted NX® or X-Limiter™ Fuse
For parallel fuses see Note ② page 24

When additional cable terminating space is required, a 54" high enclosure can be supplied to increase cable terminating space by 6". To order a 54" high enclosure, suffix the catalog number "-54H".

Cable Training and Anchor Bolt Locations

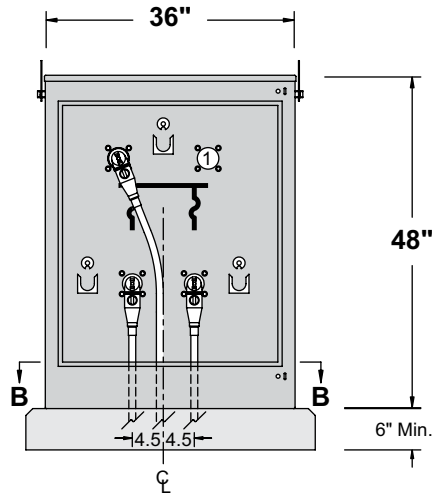

Front View
Door Removed

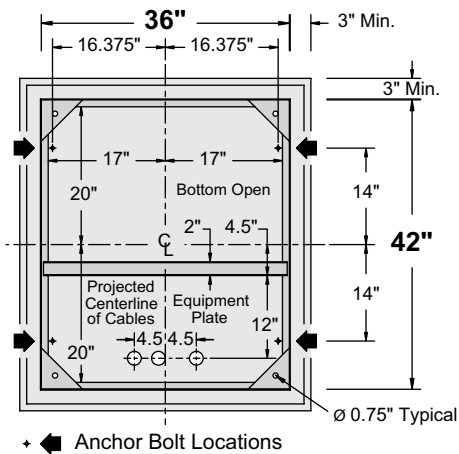
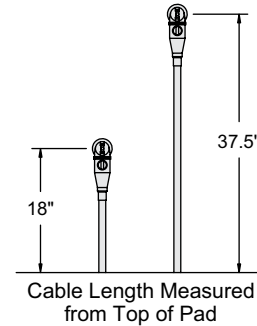

Section BB
and Typical Pad Dimensions

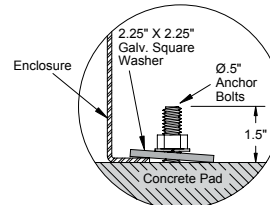

Alternate #1

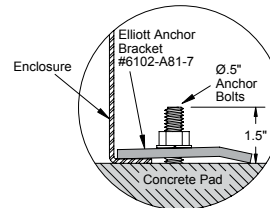

Alternate #2

① Bushing wells may be added if circuit requirements change - see page 23 in this bulletin.

EPMR-25-112-E2-CM6

15.5 kV (Code 6) 1.5 To 100 Amp NX® or
6 to 125 Amp X-Limiter™ Clip Mounted Fuse
23 kV (Code 6) 6 to 40 Amp
Clip Mounted NX® or X-Limiter™ Fuse
For parallel fuses see Note ② page 24

When additional cable terminating space is required, a 54" high enclosure can be supplied to increase cable terminating space by 6". To order a 54" high enclosure, suffix the catalog number "-54H".

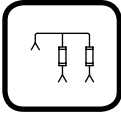

Single Phase – Three Ways Per Phase

200 Amp Elliott Air-Insulated Bushing Wells
15.2 kV Max Design
125 kV BIL

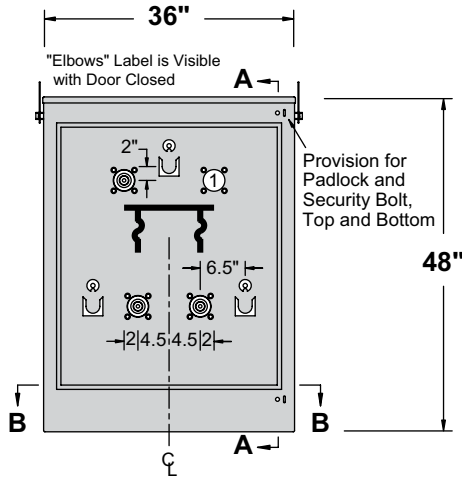

Front View
Door Removed

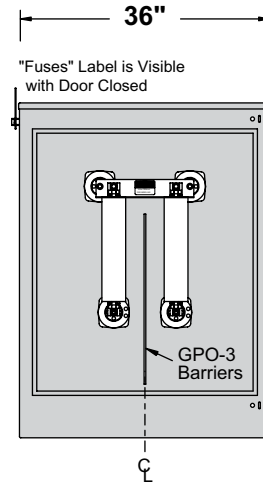

Rear View
Door & Door Safety
Barrier Removed

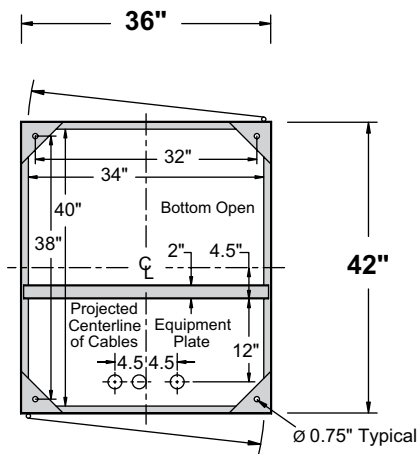

Section BB

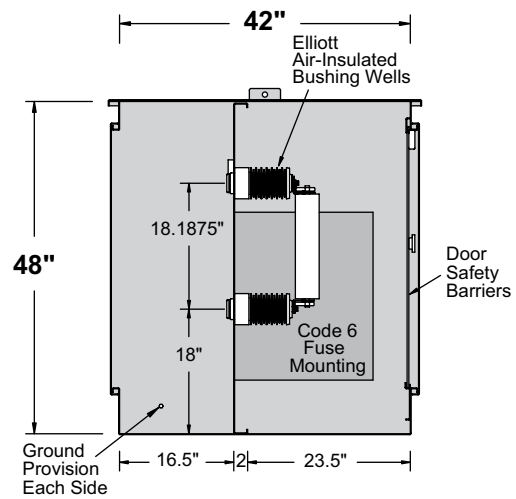

Section AA

① Bushing wells may be added if circuit requirements change - see page 23 in this bulletin.

EPMR-25-112-E2-CM6

15.5 kV (Code 6) 1.5 To 100 Amp NX® or
6 to 125 Amp X-Limiter™ Clip Mounted Fuse
23 kV (Code 6) 6 to 40 Amp
Clip Mounted NX® or X-Limiter™ Fuse
For parallel fuses see Note ② page 24

When additional cable terminating space is required, a 54" high enclosure can be supplied to increase cable terminating space by 6". To order a 54" high enclosure, suffix the catalog number "-54H".

Cable Training and Anchor Bolt Locations

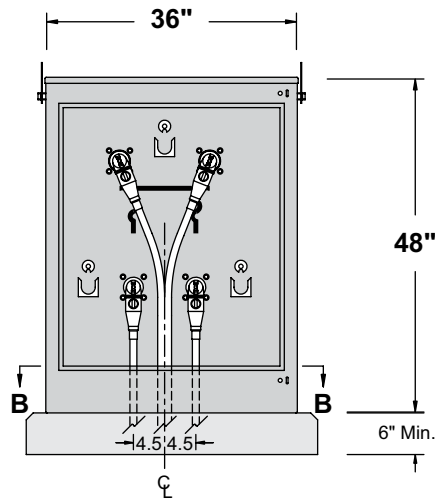

Front View
Door Removed

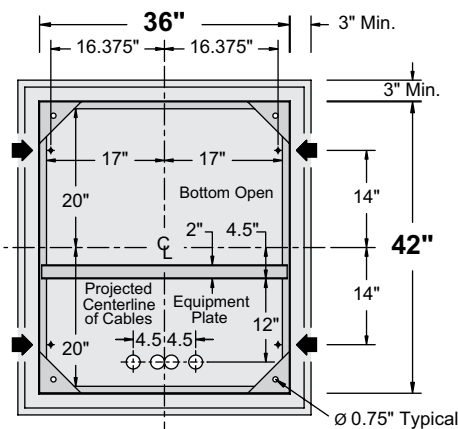
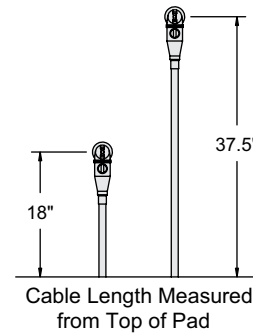

Section BB
and Typical Pad Dimensions

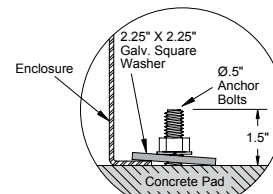

Alternate #1

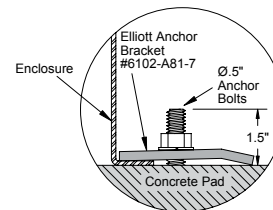

Alternate #2

EPMR-25-122-E2-CM6

15.5 kV (Code 6) 1.5 To 100 Amp NX® or
6 to 125 Amp X-Limiter™ Clip Mounted Fuse
23 kV (Code 6) 6 to 40 Amp
Clip Mounted NX® or X-Limiter™ Fuse
For parallel fuses see Note ② page 24

When additional cable terminating space is required, a 54" high enclosure can be supplied to increase cable terminating space by 6". To order a 54" high enclosure, suffix the catalog number "-54H".

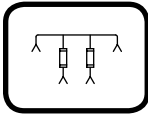

Single Phase – Four Ways Per Phase

200 Amp Elliott Air-Insulated Bushing Wells
15.2 kV Max Design
125 kV BIL

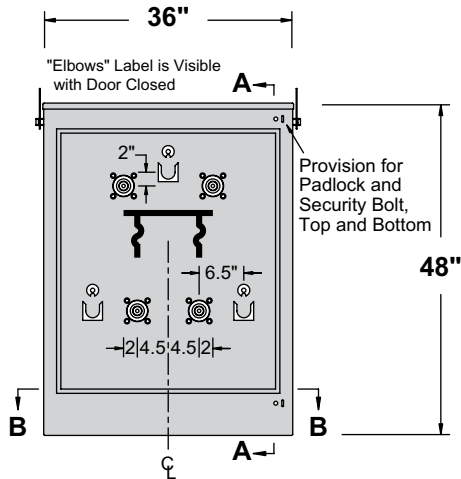

Front View
Door Removed

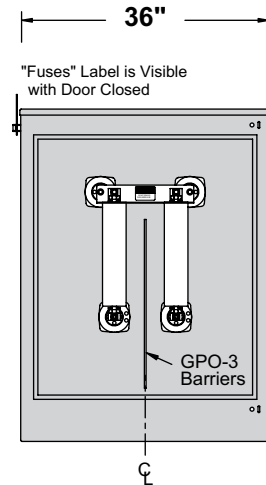

Rear View
Door & Door Safety
Barrier Removed

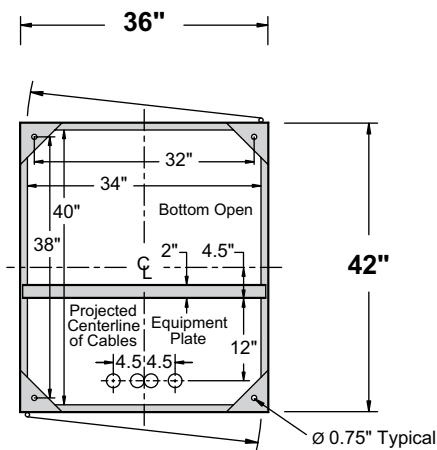

Section BB

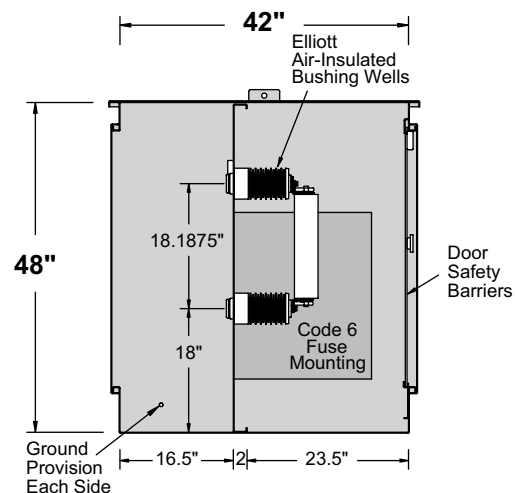

Section AA

EPMR-25-122-E2-CM6

15.5 kV (Code 6) 1.5 To 100 Amp NX® or
6 to 125 Amp X-Limiter™ Clip Mounted Fuse
23 kV (Code 6) 6 to 40 Amp
Clip Mounted NX® or X-Limiter™ Fuse
For parallel fuses see Note ② page 24

When additional cable terminating space is required, a 54" high enclosure can be supplied to increase cable terminating space by 6". To order a 54" high enclosure, suffix the catalog number "-54H".



25-kV Safefront Mini-Switch Phase Isolated Pad-Mounted Switchgear

125 Amp (Max) Clip-Mounted Current-Limiting Fuses

Bulletin
400-206
Page 12 2018

Cable Training and Anchor Bolt Locations

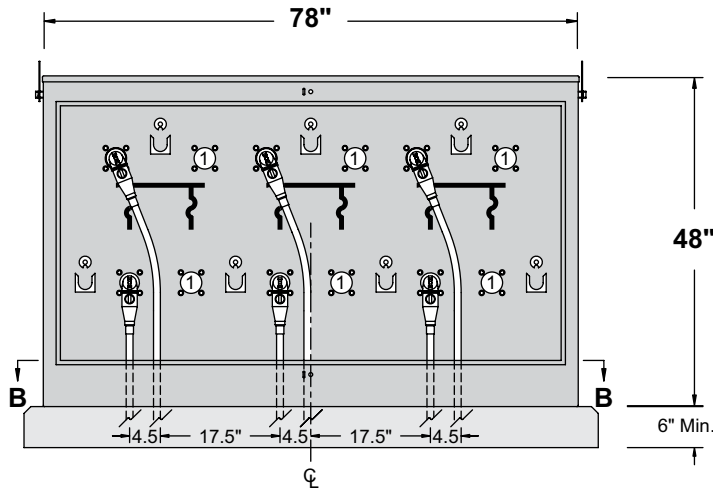

Front View
Doors Removed

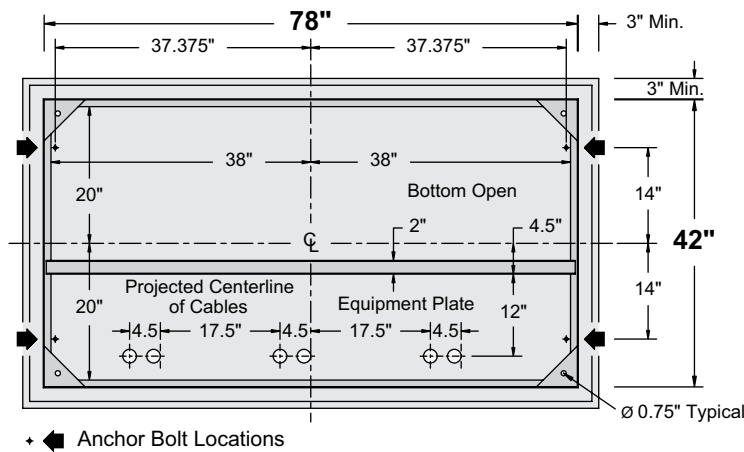
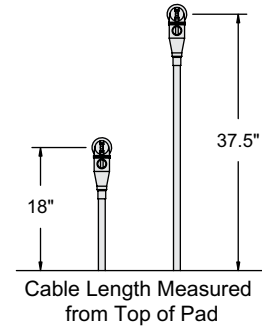

Section BB
and Typical Pad Dimensions

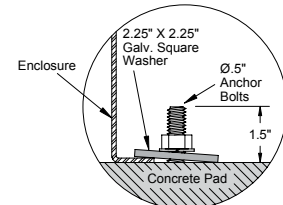

Alternate #1

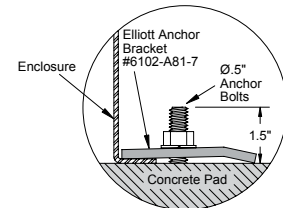

Alternate #2

① Bushing wells may be added if circuit requirements change - see page 23 in this bulletin.

EPMR-25-311P-E2-CM6

15.5 kV (Code 6) 1.5 To 100 Amp NX® or
6 to 125 Amp X-Limiter™ Clip Mounted Fuse
23 kV (Code 6) 6 to 40 Amp
Clip Mounted NX® or X-Limiter™ Fuse
For parallel fuses see Note ② page 24

When additional cable terminating space is required, a 54" high enclosure can be supplied to increase cable terminating space by 6". To order a 54" high enclosure, suffix the catalog number "-54H".

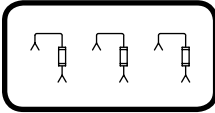

Three Phase – Two Ways Per Phase
200 Amp Elliott Air-Insulated Bushing Wells
15.2/26.3 kV Grounded Wye Max Design
125 kV BIL

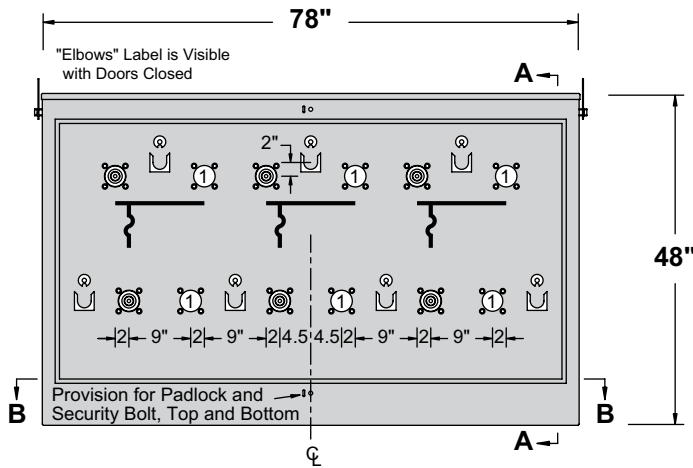

Front View
Doors Removed

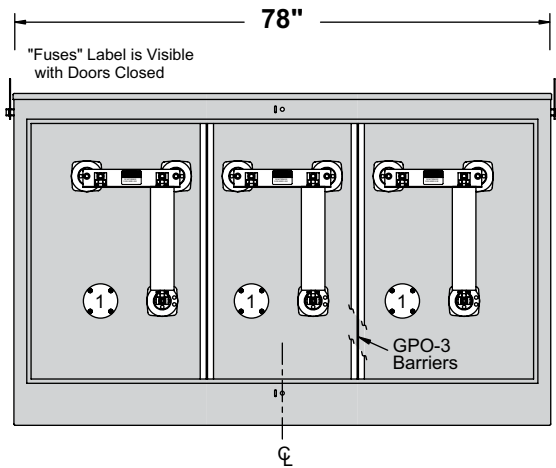

Rear View
Doors & Door Safety
Barriers Removed

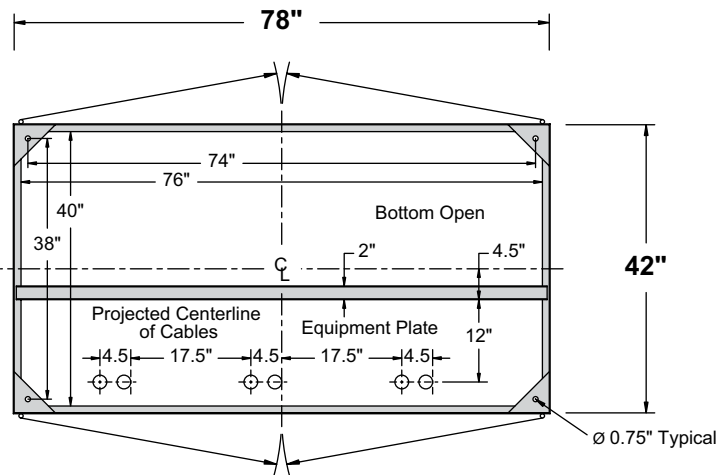

Section BB

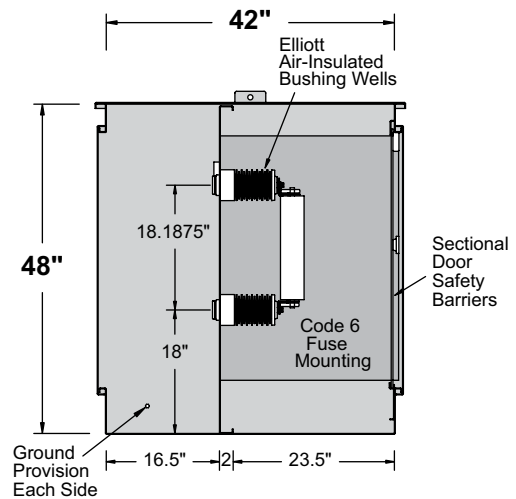

Section AA

① Bushing wells may be added if circuit requirements change - see page 23 in this bulletin.

EPMR-25-311P-E2-CM6

15.5 kV (Code 6) 1.5 To 100 Amp NX® or
6 to 125 Amp X-Limiter™ Clip Mounted Fuse
23 kV (Code 6) 6 to 40 Amp
Clip Mounted NX® or X-Limiter™ Fuse
For parallel fuses see Note ② page 24

When additional cable terminating space is required, a 54" high enclosure can be supplied to increase cable terminating space by 6". To order a 54" high enclosure, suffix the catalog number "-54H".



25-kV Safefront Mini-Switch Phase Isolated Pad-Mounted Switchgear

125 Amp (Max) Clip-Mounted Current-Limiting Fuses

Bulletin
400-206
Page 14 2018

Cable Training and Anchor Bolt Locations

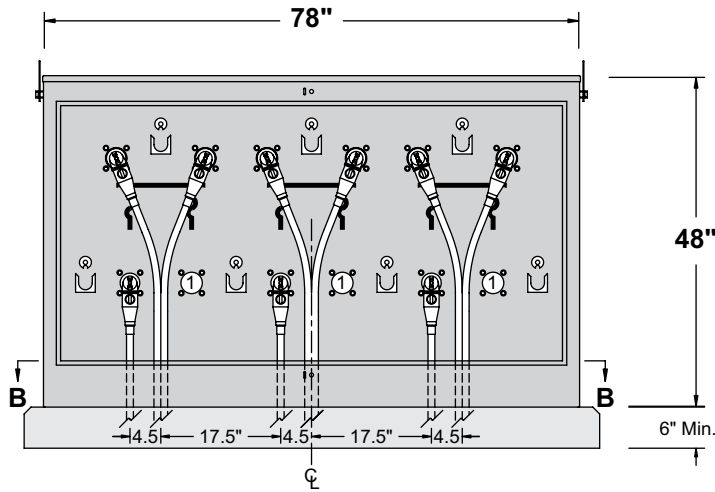

Front View
Doors Removed

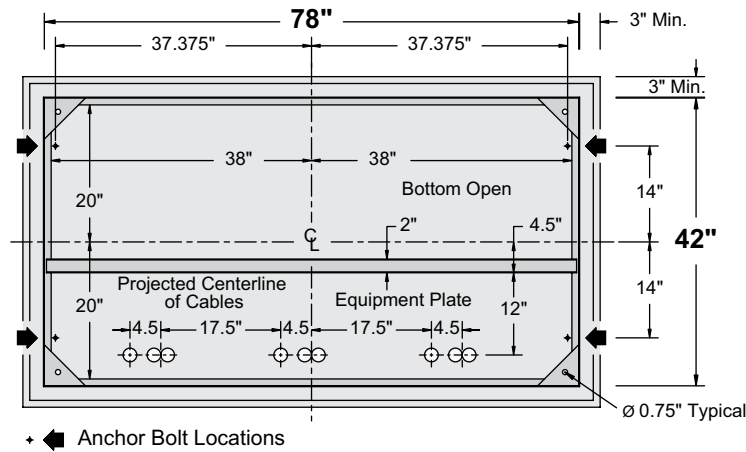
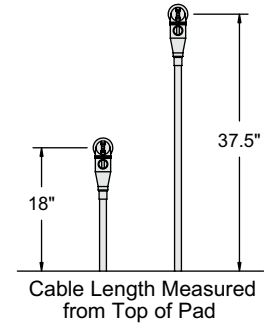

Section BB
and Typical Pad Dimensions

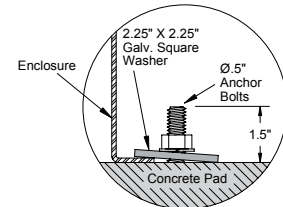

Alternate #1

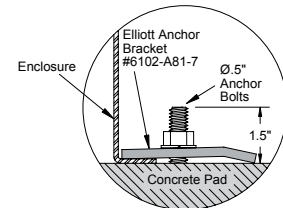

Alternate #2

Ⓢ Bushing wells may be added if circuit requirements change - see page 23 in this bulletin.

EPMR-25-321P-E2-CM6

15.5 kV (Code 6) 1.5 To 100 Amp NX® or
6 to 125 Amp X-Limiter™ Clip Mounted Fuse
23 kV (Code 6) 6 to 40 Amp
Clip Mounted NX® or X-Limiter™ Fuse
For parallel fuses see Note Ⓢ page 24

When additional cable terminating space is required, a 54" high enclosure can be supplied to increase cable terminating space by 6". To order a 54" high enclosure, suffix the catalog number "-54H".

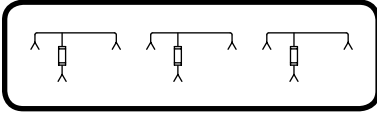

Three Phase – Three Ways Per Phase
200 Amp Elliott Air-Insulated Bushing Wells
15.2/26.3 kV Grounded Wye Max Design
125 kV BIL

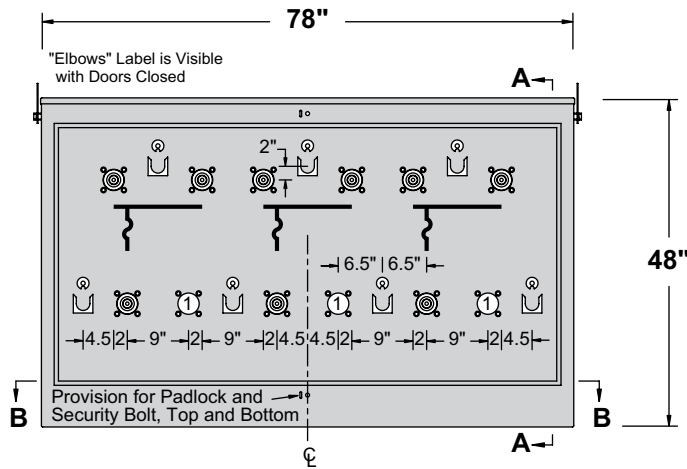

Front View
Doors Removed

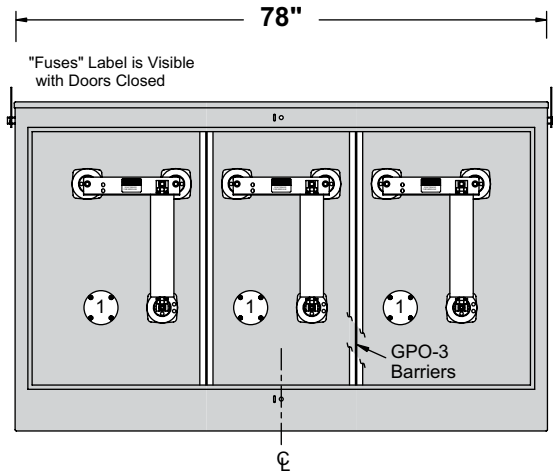

Rear View
Doors & Door Safety
Barriers Removed

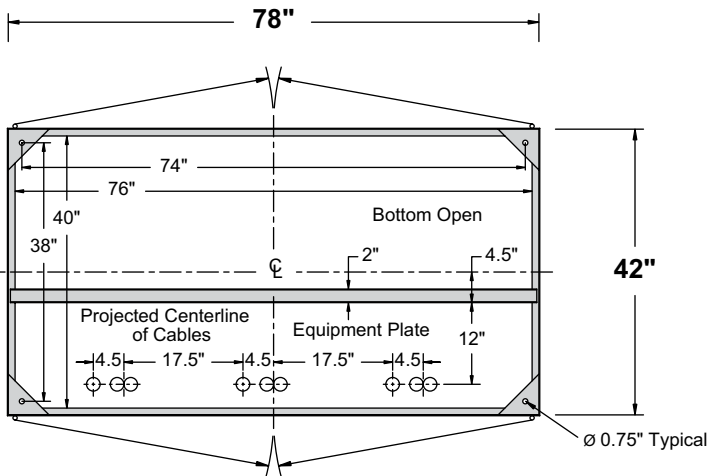

Section BB

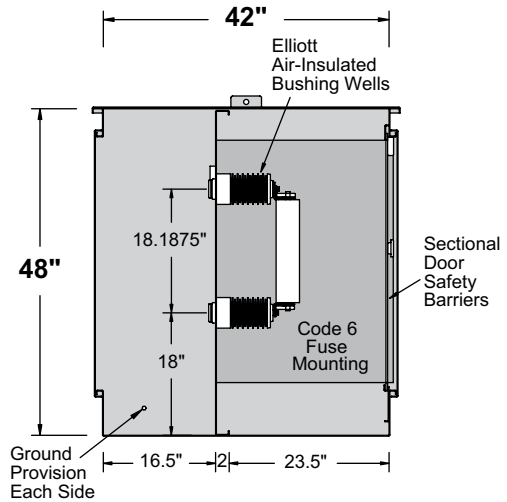

Section AA

① Bushing wells may be added if circuit requirements change - see page 23 in this bulletin.

EPMR-25-321P-E2-CM6

15.5 kV (Code 6) 1.5 To 100 Amp NX® or
6 to 125 Amp X-Limiter™ Clip Mounted Fuse
23 kV (Code 6) 6 to 40 Amp
Clip Mounted NX® or X-Limiter™ Fuse
For parallel fuses see Note ② page 24

When additional cable terminating space is required, a 54" high enclosure can be supplied to increase cable terminating space by 6". To order a 54" high enclosure, suffix the catalog number "-54H".

Cable Training and Anchor Bolt Locations

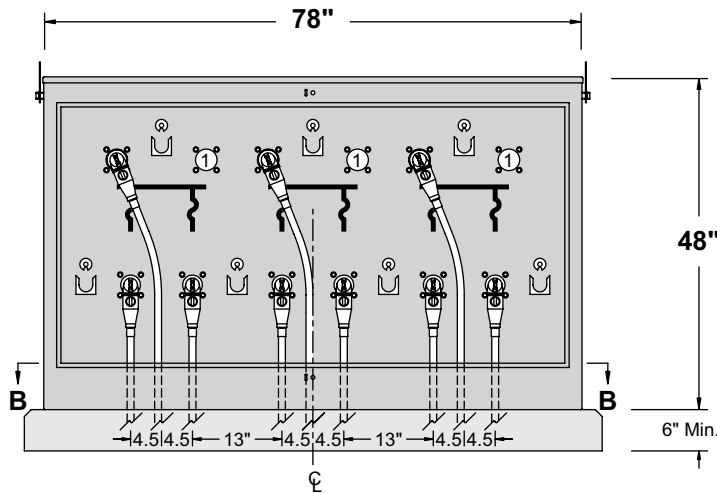

Front View
Doors Removed

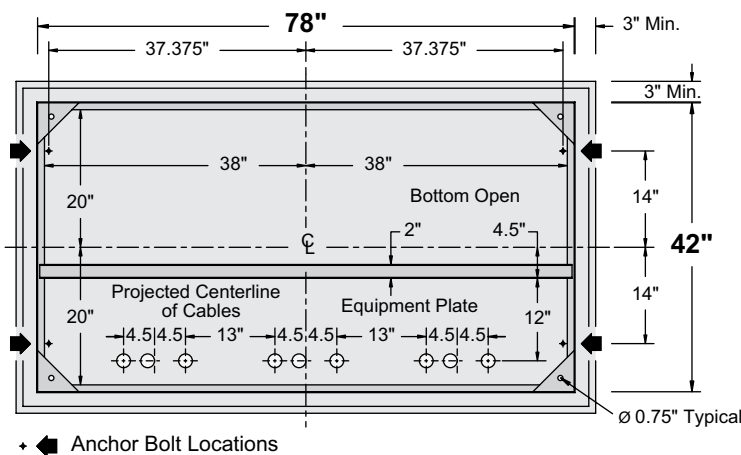
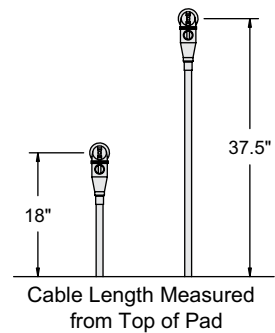

Section BB
and Typical Pad Dimensions

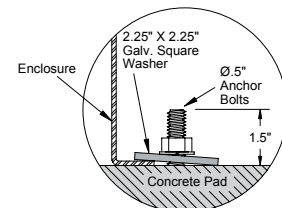

Alternate #1

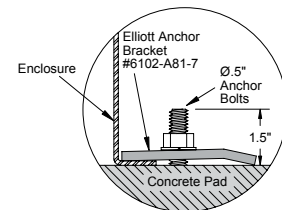

Alternate #2

① Bushing wells may be added if circuit requirements change - see page 23 in this bulletin.

EPMR-25-312P-E2-CM6

15.5 kV (Code 6) 1.5 To 100 Amp NX® or
6 to 125 Amp X-Limiter™ Clip Mounted Fuse
23 kV (Code 6) 6 to 40 Amp
Clip Mounted NX® or X-Limiter™ Fuse
For parallel fuses see Note ② page 24

When additional cable terminating space is required, a 54" high enclosure can be supplied to increase cable terminating space by 6". To order a 54" high enclosure, suffix the catalog number "-54H".

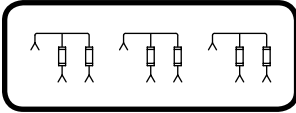

Three Phase – Three Ways Per Phase
200 Amp Elliott Air-Insulated Bushing Wells
15.2/26.3 kV Grounded Wye Max Design
125 kV BIL

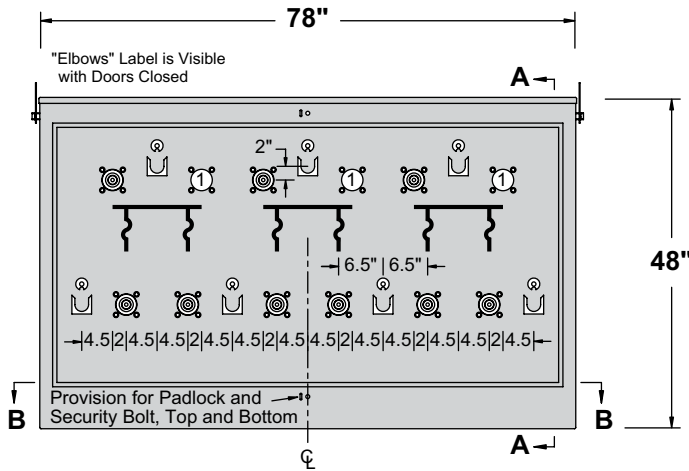

Front View
Doors Removed

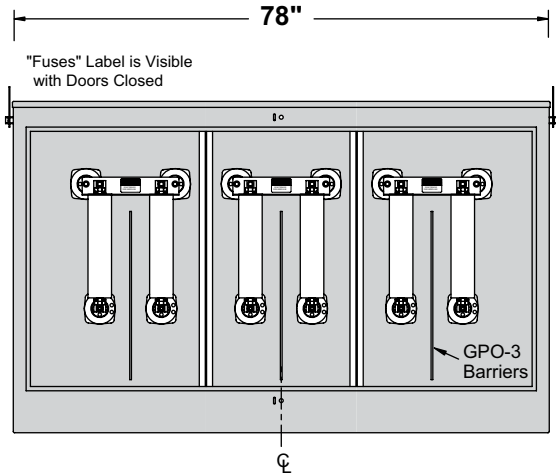

Rear View
Doors & Door Safety
Barriers Removed

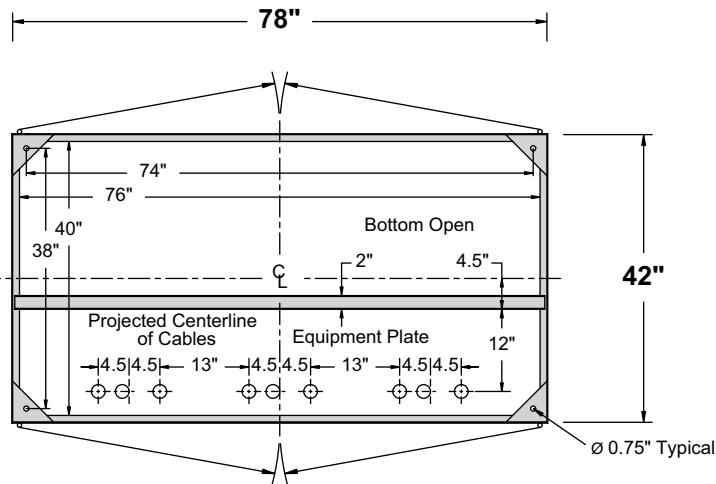

Section BB

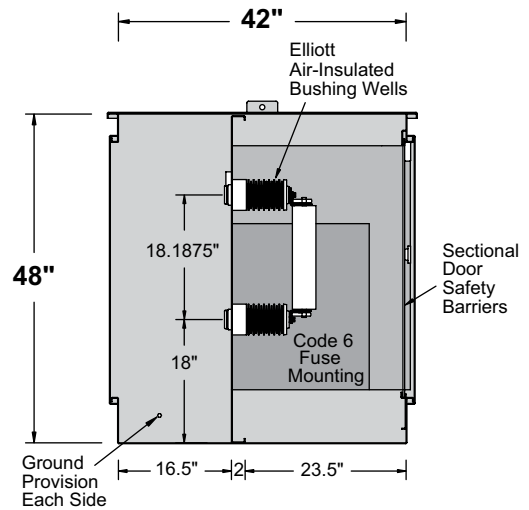

Section AA

① Bushing wells may be added if circuit requirements change - see page 23 in this bulletin.

EPMR-25-312P-E2-CM6

15.5 kV (Code 6) 1.5 To 100 Amp NX® or
6 to 125 Amp X-Limiter™ Clip Mounted Fuse
23 kV (Code 6) 6 to 40 Amp
Clip Mounted NX® or X-Limiter™ Fuse
For parallel fuses see Note ② page 24

When additional cable terminating space is required, a 54" high enclosure can be supplied to increase cable terminating space by 6". To order a 54" high enclosure, suffix the catalog number "-54H".

Cable Training and Anchor Bolt Locations

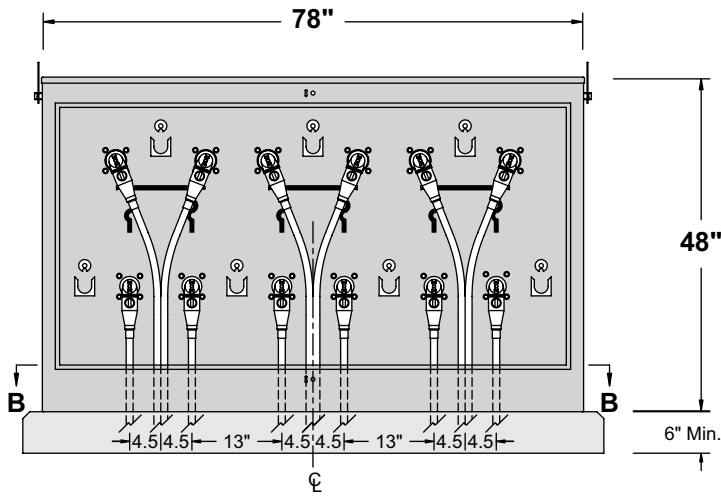

Front View
Doors Removed

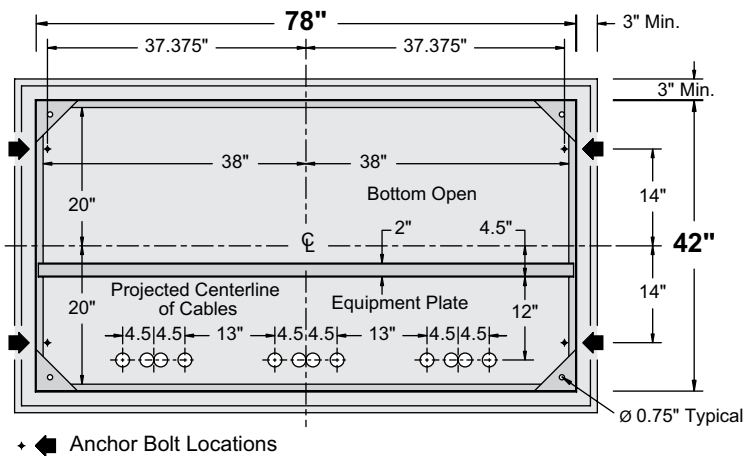
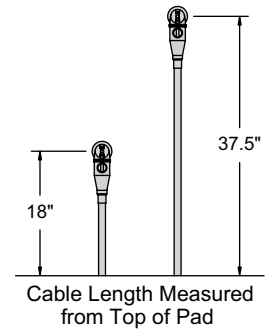

Section BB
and Typical Pad Dimensions

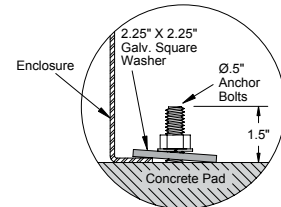

Alternate #1

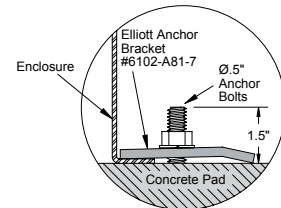

Alternate #2

EPMR-25-322P-E2-CM6

15.5 kV (Code 6) 1.5 To 100 Amp NX® or
6 to 125 Amp X-Limiter™ Clip Mounted Fuse
23 kV (Code 6) 6 to 40 Amp
Clip Mounted NX® or X-Limiter™ Fuse
For parallel fuses see Note ② page 24

When additional cable terminating space is required, a 54" high enclosure can be supplied to increase cable terminating space by 6". To order a 54" high enclosure, suffix the catalog number "-54H".

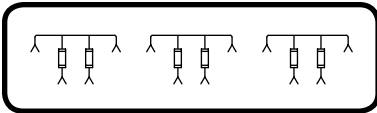

Three Phase – Four Ways per Phase
200 Amp Elliott Air-Insulated Bushing Wells
15.2/26.3 kV Grounded Wye Max Design
125 kV BIL

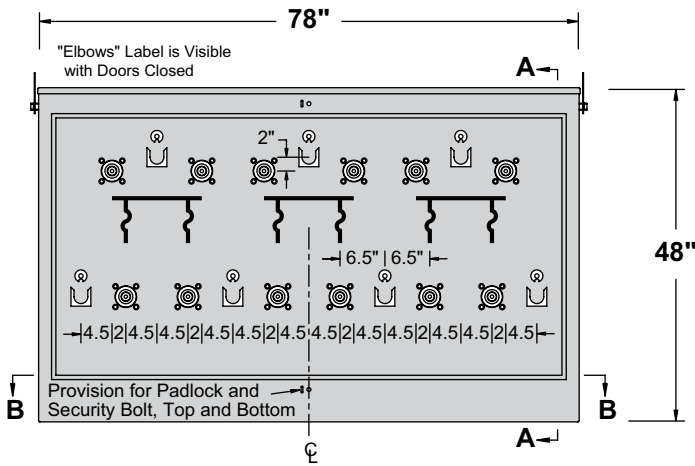

Front View
Doors Removed

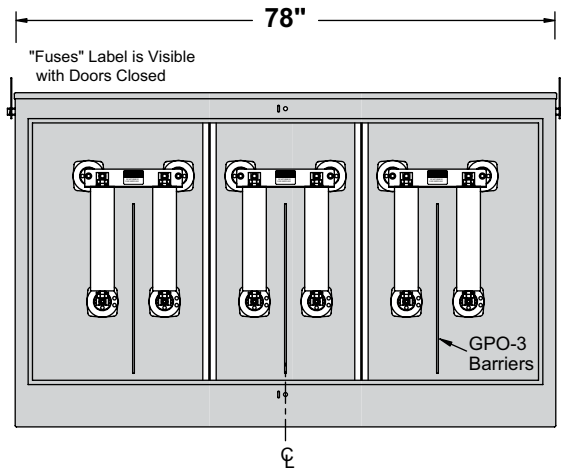

Rear View
Doors & Door Safety
Barriers Removed

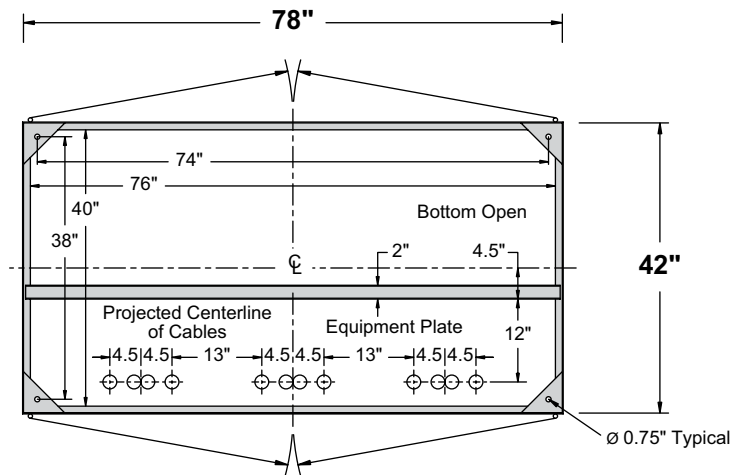

Section BB

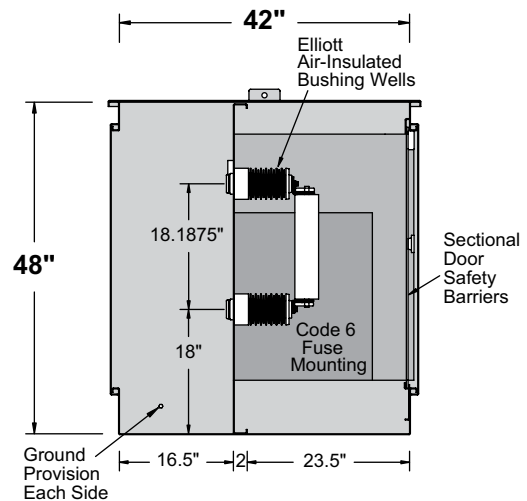

Section AA

EPMR-25-322P-E2-CM6

15.5 kV (Code 6) 1.5 To 100 Amp NX® or
6 to 125 Amp X-Limiter™ Clip Mounted Fuse
23 kV (Code 6) 6 to 40 Amp
Clip Mounted NX® or X-Limiter™ Fuse
For parallel fuses see Note ② page 24

When additional cable terminating space is required, a 54" high enclosure can be supplied to increase cable terminating space by 6". To order a 54" high enclosure, suffix the catalog number "-54H".

Typical Specification - Page 1 of 3

General

The switchgear shall be 25 kV class, 125 kV BIL, 200 ampere continuous current, suitable for use on 15.2/26.3 kV grounded wye max design systems. The switchgear shall be constructed for connection to the utility system with separable insulated connectors as described in IEEE Standard 386—latest revision (separable insulated connectors and loadbreak inserts shall be supplied by the user). The switchgear shall be designed for and contain fuse mountings in a compartment separated from the elbow compartment by a steel equipment plate. Separate access shall be provided for each compartment. A door safety barrier shall be provided inside the door(s) on the fuse compartment as recommended in IEEE Standard C2 (National Electrical Safety Code) Rule 381G. Tamper resistance shall meet the Enclosure Security requirements of IEEE Standard C57.12.28 (Pad-Mounted Equipment—Enclosure Integrity). Together, the tamper resistance and the door safety barrier shall resist unauthorized entry, protect authorized and unauthorized persons, and provide positive safety features when installed in areas accessible to the general public. The switchgear shall be constructed for outdoor installation in areas subject to heavy precipitation and in areas with windblown contamination. The equipment shall be “air-insulated” and completely assembled prior to shipment.

Enclosure Construction

The enclosure shall be tamper-resistant, all-welded construction utilizing 11-gauge minimum sheet steel. Corner plates and braces shall be used as necessary to assure rigidity. The enclosure top shall be cross-kinked to provide watershed and rigidity. The enclosure shall be open bottom with a 1-inch flange inside, all around. Separate compartments shall be provided for cable termination and for fuse mountings—each compartment equipped with its own individual access door(s) furnished with a stainless steel door holder that will latch the door open 100 degrees and 140 degrees and resist accidental closing. The equipment plate separating the two compartments shall be full length, constructed with 11-gauge minimum sheet steel braced to assure rigidity when operating the elbows and fuses. Doors shall be provided with provisions for padlocking and a recessed penta-head (or hex-head) security bolt to prevent unauthorized entry (coordinated to prevent installation of the padlock until the security bolt is tightened *when closing the door(s)* and to prevent a wrench from operating the security bolt until the padlock is removed *when opening the door(s)*). The security bolt shall be made captive with a stainless steel washer compressed to an oval shape to severely discourage removal. Hinges shall be stainless steel (with stainless steel pins not less than 0.3125-inch diameter) and shall be welded to both the enclosure and the door(s) to maintain door alignment for the life of the equipment. The enclosure

shall be nonventilated to minimize the entrance of airborne contamination, insects, rodents or reptiles. The protective finish shall include necessary grinding, cleaning and phosphatizing, two-component rust-inhibiting epoxy primer and a Pad-Mount Green two-component polyurethane top coat finish (Munsell color 7GY 3.29/1.5). The primer and top coat shall be electronically monitored during application to insure proper ratio and mixing of each component. Total average thickness of paint (after curing) shall be not less than 5 mils. The protective coating shall meet the Enclosure Coating System requirements of IEEE Standard C57.12.28 (Pad-Mounted Equipment—Enclosure Integrity). Removable lift provisions, adequate to withstand handling with normal utility equipment, shall be provided on the outside of the enclosure. Threaded openings for lift provision bolts shall be blind holes to prevent the entrance of wire or other foreign objects into the enclosure when lift provisions are removed.

Bushings and Terminals

Bushings shall be 200 ampere Elliott #1101-225B, 25 kV class (15.2 kV to ground) Air-Insulated Bushing Wells, 125 kV BIL, per IEEE Standard 386-2016 Fig. 3 (Interface 3: a 200 A Bushing Well Interface) *for use with either 8.3/14.4 kV or 15.2/26.3 kV separable insulated connectors* (Elastimold®, Eaton's Cooper Power Systems or other approved equal). The bushing wells shall be pressure-molded cycloaliphatic epoxy with a 0.75-inch diameter copper conductor on the “air-insulated” side that is drilled and tapped 0.375-inch – 16UNC x 1-inch deep to provide direct connection of the bus and/or live parts. Leakage distance from the apparatus connection end of the bushing well to ground shall be not less than 30 inches to assure trouble-free operation in a wet and/or contaminated environment. Integral shielding shall be provided to eliminate partial discharge caused by off-center mounting and mounting holes that may have sharp edges or burrs. Bushing wells shall mount in a 3.125-inch diameter opening and bolt in place to allow field replacement with standard tools. The bushing well mounting bolts shall be self-locking stainless steel serrated-flange hex-head bolts that “cut” through the enclosure protective finish to ground the integral shielding of each bushing well. The head of one or more of the mounting bolts for each bushing well shall include a 0.156-inch diameter hole to provide a connection to ground for the loadbreak insert shielding ground wire as recommended by separable insulated connector manufacturers. To assure adequate strength for apparatus support, the bushing well shall withstand a minimum cantilever loading of 600 pounds for five minutes without damage. The bushing well interface shall be free of all voids, holes and heat sinks to assure proper mating with separable insulated connectors. Each bushing well shall be tested in free air, mounted in a grounded steel plate not less than 10 inches x 10 inches, with a bushing well plug (Eaton's Cooper

Typical Specification - Page 2 of 3

Power Systems #IBWP225 or equal) installed in the well interface to accurately simulate operating conditions (*gas or liquid dielectric in the interface shall not be acceptable for this test*). Each bushing well shall meet the requirements for 25 kV devices in accordance with IEEE Standard 386 (latest revision), including 100 percent production testing.

Bus and Fuse Mountings

Bus shall be copper with all burrs and sharp corners removed prior to installation. Fuse clips shall be keyed to prevent rotation and to maintain alignment. Positive pressure shall be assured by use of stainless steel fasteners and lock washers or compression washers at all connection points. All connections shall provide direct contact of current-carrying parts and shall not depend on current transfer through fastener thread-to-thread contact. The bus shall be arranged to allow inspection and tightening of all connections (with standard hand tools) without the necessity of removing phase barriers, ground barriers, or fuse mountings. Fuses and their blown-fuse indicators shall be visible (*when the fuse compartment door(s) are open*) without removal of the clear-polycarbonate door safety barrier to allow easy identification of blown fuses without de-energizing or removing the fuse from service. Electrical components shall be "air-insulated" and positioned to allow visual inspection of all internal connections and components *without removing the clear-polycarbonate door safety barrier*, de-energizing or removing the equipment from service.

Alternate 1: Fuse mountings shall be Mounting Code 6 to accept 1.5 amp to 100 amp (max), 15.5 kV Eaton's Cooper Power Systems NX® and 6 amp to 125 amp (max), 15.5 kV Eaton's Cooper Power Systems X-Limiter™ clip-mounted current-limiting fuses. *When 1.5 amp to 40 amp 15.5 kV Code 5 fuses are supplied, one Elliott #3901-CM5-6 fuse extender per fuse shall be supplied to extend the Code 5 fuse length to fit Mounting Code 6 fuse mountings.* A Warning Sign, Elliott #7201-W2003-318, shall be provided inside the fuse compartment door(s) to warn the operator to "Park the load side cable before installing or removing fuses." A Danger Sign, Elliott #7203-D2003-313, shall be provided in a prominent location near the fuse clips to warn the operator "Do not remove fuse under load." Spare-fuse storage is optional. When specified, spare-fuse storage shall be provided that will allow storage (and retrieval) of Code 5 or Code 6 fuses with hot-line tools. Spare-fuse storage shall not interfere with opening or closing the doors.

Alternate 2: Fuse mountings shall be Mounting Code 6 to accept 1.5 amp to 40 amp (max), 23 kV Eaton's Cooper Power Systems NX® and X-Limiter™ clip-mounted current-limiting fuses. A Warning Sign, Elliott #7201-W2003-318, shall be provided inside the fuse compartment door(s) to warn the operator to "Park the load side cable before installing or removing fuses." A

Danger Sign, Elliott #7203-D2003-313, shall be provided in a prominent location near the fuse clips to warn the operator "Do not remove fuse under load." Spare-fuse storage is optional. When specified spare-fuse storage shall be provided that will allow storage (and retrieval) of Code 5 or Code 6 fuses with hot-line tools. Spare-fuse storage shall not interfere with opening or closing the doors.

Barriers

Phase and ground barriers shall be provided to assure correct phase-to-phase and phase-to-ground clearances for correct operation at rated voltage. These barriers shall be glass-reinforced polyester (NEMA GPO-3 class material) not less than 0.1875-inch thick.

For each phase, a removable insulating barrier with a "DANGER – Keep Out! – Hazardous Voltage" sign, Elliott #7203-D2003-309, shall be located inside the door(s) on the fuse compartment as recommended in Rule 381G of IEEE Standard C2 (National Electrical Safety Code). These *sectional door safety barriers* shall be constructed of 0.25-inch clear polycarbonate (Lexan or equal) and *shall completely close the opening* to each phase. Each barrier shall be provided with a nonconductive safety latch requiring a positive action to remove the barrier. Handles and other hardware extending through the door safety barriers shall be nonconductive material. Handles shall be keyed to prevent rotation for secure handling. *Complete visual inspection of the internal components shall be possible without removing the door safety barrier.*

Grounding Provisions

Two high-conductivity bronze eyebolt-type ground lugs, which accept #6 through #2/0 copper conductor, shall be installed in the cable terminating compartment (located on each side of the door opening in an accessible position).

Accessory Equipment

Stainless steel parking stands shall be provided in the quantity required to allow use of feed-thru bushings, parking bushings and grounding bushings. The parking stands shall be welded in place, in a position to allow the use of hot-line tools for installation of feed-thru bushings, etc. The parking stands shall be *unpainted* (except welds shall be painted) *to provide a ground* for feed-thru bushings and other devices that may be placed into the parking stands. *Keyed retainers* shall be welded above each parking stand *to prevent slipping or accidental removal* of portable devices such as feed-thru bushings, etc.

A corrosion proof nameplate with permanent thermal transfer printing shall be installed inside one door on the elbow compartment. It shall be located at the top corner farthest from the elbows when the door is open. The nameplate will provide Type of Equipment, Model Number,

Typical Specification - Page 3 of 3

Amps Continuous, kV Maximum, BIL, Serial Number, Job Number, Date Manufactured and Weight of Equipment.

Bus and fuse connections between bushings shall be displayed (on the cable side of the equipment plate) using 0.5-inch-wide solid orange-color pressure-sensitive vinyl tape and die-cut orange-color pressure-sensitive vinyl fuse symbols not less than 2.5 inches high. The resulting schematic shall clearly indicate the circuit arrangement of the switchgear. The schematic shall be legible at a distance of six feet or more.

When enclosures have more than one door (or other access provision) each access shall be labeled in near proximity of the locking provisions with a pressure-sensitive vinyl label using letters not less than 0.375-inch nor more than 0.625-inch high. The label shall indicate the type of equipment behind the access (elbows, fuses, bus, etc.).

When specified, four anchor-bolt brackets, Elliott #6102-A81-7 or approved equal, shall be supplied with each switchgear to provide a means of clamping the equipment to

the concrete pad.

Packaging

Each switchgear shall be bolted to a solid-top wood pallet (to prevent the forks of a forklift truck from entering the open bottom of the equipment) to prevent hidden damage. The equipment shall be wrapped with 0.125-inch thick polyethylene foam or other suitable material to minimize damage to the finish during shipment.

Drawings

When specified, drawings shall be furnished for each switchgear that include:

- 1) enclosure dimensions and location of components.
- 2) proposed cable-training layout and dimensions.
- 3) proposed pad dimensions and location of anchor bolts.

200 Amp Bushing Well #1101-225B

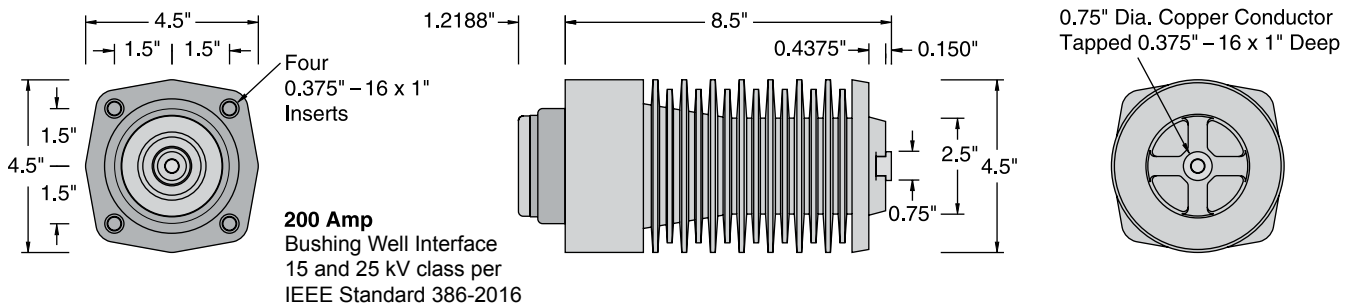

| | |
|--|-------------|
| Voltage Class..... | 25 kV |
| Phase-to-Ground Voltage..... | 15.2 kV |
| BIL..... | 125 kV |
| AC Withstand - 1 Min. Dry..... | 40 kV |
| 10 Sec. Dew..... | 40 kV |
| DC Withstand - 15 Min. Dry..... | 78 kV |
| Corona Extinction Level - Minimum..... | 19 kV |
| Continuous Current..... | 200 Amps |
| Momentary - RMS, Sym., 0.17 sec..... | 10,000 Amps |
| RMS, Sym., 3 sec..... | 3,500 Amps |

| | |
|---|----------------|
| Leakage Distance, Inches..... | 34 |
| Dry Arcing Distance, Inches..... | 8.5 |
| Mechanical - Strength Rating, Pounds | |
| Cantilever, Ultimate 2.5 inches past end..... | >1,000 |
| Tensile, Pounds..... | >5,000 |
| Torsion, Inches-Pounds (bolt breaks)..... | >700 |
| Compression, Pounds..... | 20,000 |
| Insert Thread Size..... | 0.375"-16 x 1" |
| Conductor (live end) Thread Size..... | 0.375"-16 x 1" |
| Net Weight, Pounds (kg)..... | 6.75 (3.06) |

Bushing Well Installation Instructions

The single-phase Safefront Mini-Switches shown in this bulletin have equipment plates punched to accept four bushing wells. The three-phase Safefront Mini-Switches have equipment plates punched to accept twelve bushing wells. The extra mounting holes are closed with “bushing-style” insulators or adapter plates. If circuit requirements change, bushing wells can be added or removed to provide the circuit arrangements shown in this bulletin. The mounting hardware

used to mount the “bushing-style” insulator or adapter plate is the same hardware used to install a bushing well. There is no need to drill holes when modification is required.

NOTE: *The mini-switch must be de-energized and grounded in accordance with your company's normal safety procedure before any modifications are made.*

Procedure for Bushing Well Installation

NOTE: *The shipping cap on the bushing well should be left in place to prevent contamination of the interface.*

1. Remove the fuses.
2. Remove the bus bar.
3. Remove the “bushing-style” insulator or adapter plate from the equipment plate (retain for future use).
4. Install the bushing well into the mounting hole from the fuse side.
5. Install the serrated-flange bolts. Bolts should be tightened in a uniform manner applying no more than 90 inch-pounds torque to each bolt. The serrated-flange bolts must “cut” into the mounting plate to provide a connection from the shielding to the grounded equipment mounting plate.
6. Connect the copper bus bar to the bushing well just installed using hardware previously removed.
7. Tighten the bolt on both ends of the bus bar no more than 216 inch-pounds.

IMPORTANT: *Do not energize this bushing well with only the shipping cap in place.* To do so would lead to failure of the bushing well and create a hazard to operating personnel. *This product is designed to be used only when it is mated with an appropriate 25 kV class bushing insert and elbow conforming to the latest revision of IEEE Standard 386.* The bushing insert and elbow should be installed in accordance with the instructions supplied by the connector manufacturer.

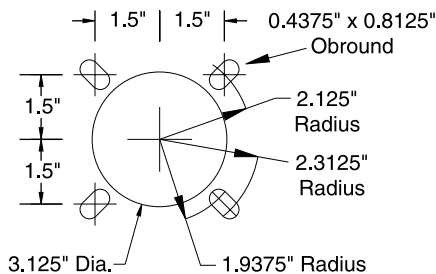

Uni-Mount Mounting Holes

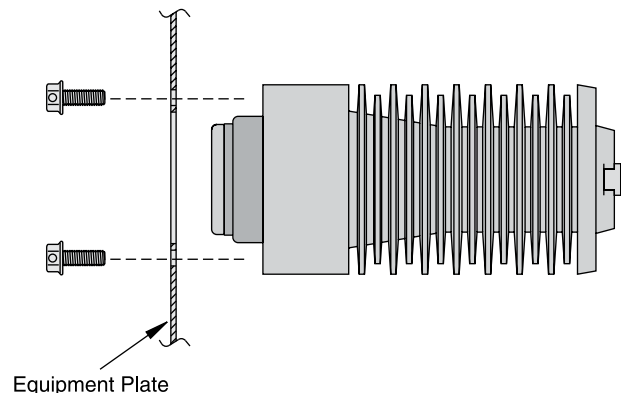

**Fuse Selection Information
NX® and X-Limiter™ Current-Limiting Fuses Clip-Mounted Style**

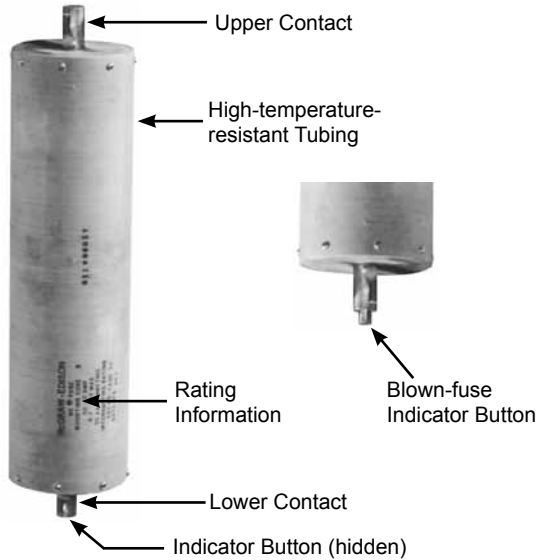

**Eaton's Cooper Power Systems
Type NX® Current-Limiting Fuse**

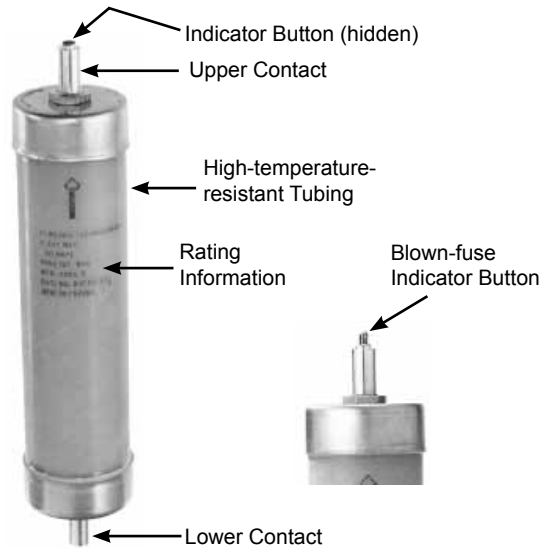

**Eaton's Cooper Power Systems
X-Limiter™ Full-Range Current-Limiting Fuse**

| 50,000 amps Symmetrical Interrupting Rating | | | | |
|---|--------------------------------|--|--------------------------|---------------------------------|
| Rating | | Mounting ^① Code Number* | NX® Catalog Number | X-Limiter™ Catalog Number |
| Voltage (kV) | Continuous Current (amp) | | | |
| For Single and Parallel Unit Clip-Style Mountings | | | | |
| 15.5 | 1.5 | 5 | FA3H1 | -- |
| | 3 | 5 | FA3H3 | -- |
| | 4.5 | 5 | FA3H4 | -- |
| | 6 | 5 | FA4H6 | 155F06-I/I |
| | 8 | 5 | FA4H8 | 155F08-I/I |
| | 10 | 5 | FA4H10 | 155F10-I/I |
| | 12 | 5 | FA4H12 | 155F12-I/I |
| | 18 | 5 | FA4H18 | 155F18-I/I |
| | 20 | 5 | FA4H20 | 155F20-I/I |
| | 25 | 5 | FA4H25 | 155F25-I/I |
| | 30 | 5 | FA4H30 | 155F30-I/I |
| | 40 | 5 | FA4H40 | 155F40-I/I |
| | 50 | 6 | FA4H50 | 155F50-I/I |
| | 65 | 6 | FA4H65 | 155F65-I/I |
| 80 | 6 | FA4H80 | 155F80-I/I | |
| 100 | 6 | FA4H100† | 155F100-I/I | |
| 125 | 6 | -- | 155F125-I/I | |
| 23 ^② | 6 | 6 | FA5H6 | 23F006-I/I |
| | 8 | 6 | FA5H8 | 23F008-I/I |
| | 10 | 6 | FA5H10 | 23F010-I/I |
| | 12 | 6 | FA5H12 | 23F012-I/I |
| | 18 | 6 | FA5H18 | 23F018-I/I |
| | 20 | 6 | FA5H20 | 23F020-I/I |
| | 25 | 6 | FA5H25 | 23F025-I/I |
| | 30 | 6 | FA5H30 | 23F030-I/I |
| | 40 | 6 | FA5H40 | 23F040-I/I |

*Code number of mounting must match code number of fuse.

† At present, 100 amp, 15.5-kV fuse is suitable for systems up to 13.5 kV maximum voltage rating.

① Fuse extenders must be used to extend 1.5 to 40 amp fuses so they fit the 125 amp fuse mountings in Elliott Safefront Switchgear.

| Catalog No. | Extends Fuses Code | To Fit Mfg. Code |
|--|-----------------------|---------------------|
| 3901- | | |
| CM5-6 | 5 | 6 |
| For other combinations see Bulletin 3901 | | |

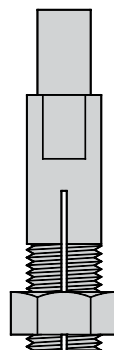

Installation is easy using two adjustable wrenches. The fuse extender is pushed onto the top contact of the fuse and the compression nut is tightened. To remove the extender, loosen the compression nut and pull the extender off.

② See Bulletin 3902. The Elliott Parallel Fuse Adapter is designed to parallel two clip-mounted fuses and allow the assembly to be installed in a fuse mounting designed for a single fuse. *For example: two 40 amp Code 6 fuses assembled in the Parallel Fuse Adapters may be installed in a Code 6 single fuse mounting to achieve an 80 amp rating.*