

Heavy-duty 11-gauge steel enclosure is all-welded construction for long life

200-amp Elliott air-insulated bushing wells accept IEEE Standard inserts and elbows

Parking stands for the upper two phases extend 3" per IEEE C57.12.26 for improved switching

11-gauge steel equipment plate is rigid for easier elbow operation

"Elbows" compartment label is visible with door closed

Bolt head with grounding eye for attachment of insert ground wire

Bus schematic is orange-colored vinyl for high visibility

Corrosion proof nameplate is located to provide easy access for the operator

Parking stands are unpainted stainless steel and provide space and grounding for feed-thru and other portable devices

Keyed retainers to prevent slipping or accidental removal of portable devices

Door-holder rods are stainless steel and hold the door open 100 degrees or 140 degrees

Superlife finish includes phosphatizing, rust-inhibiting epoxy primer and Pad-Mount Green (Munsell 7GY 3.29/1.5) polyurethane top coat - over 3 mils dry

Ground lugs on each wall of the elbow compartment accept #6 - #2/0 ground cable

Open bottom and extra depth of elbow compartment provide space for use of feed-thru and other portable devices with the doors open and closed

ENCLOSURE OPTIONS:

- 1) 0.125" #5052H32 Aluminum
- 2) 12-gauge #304L Stainless Steel

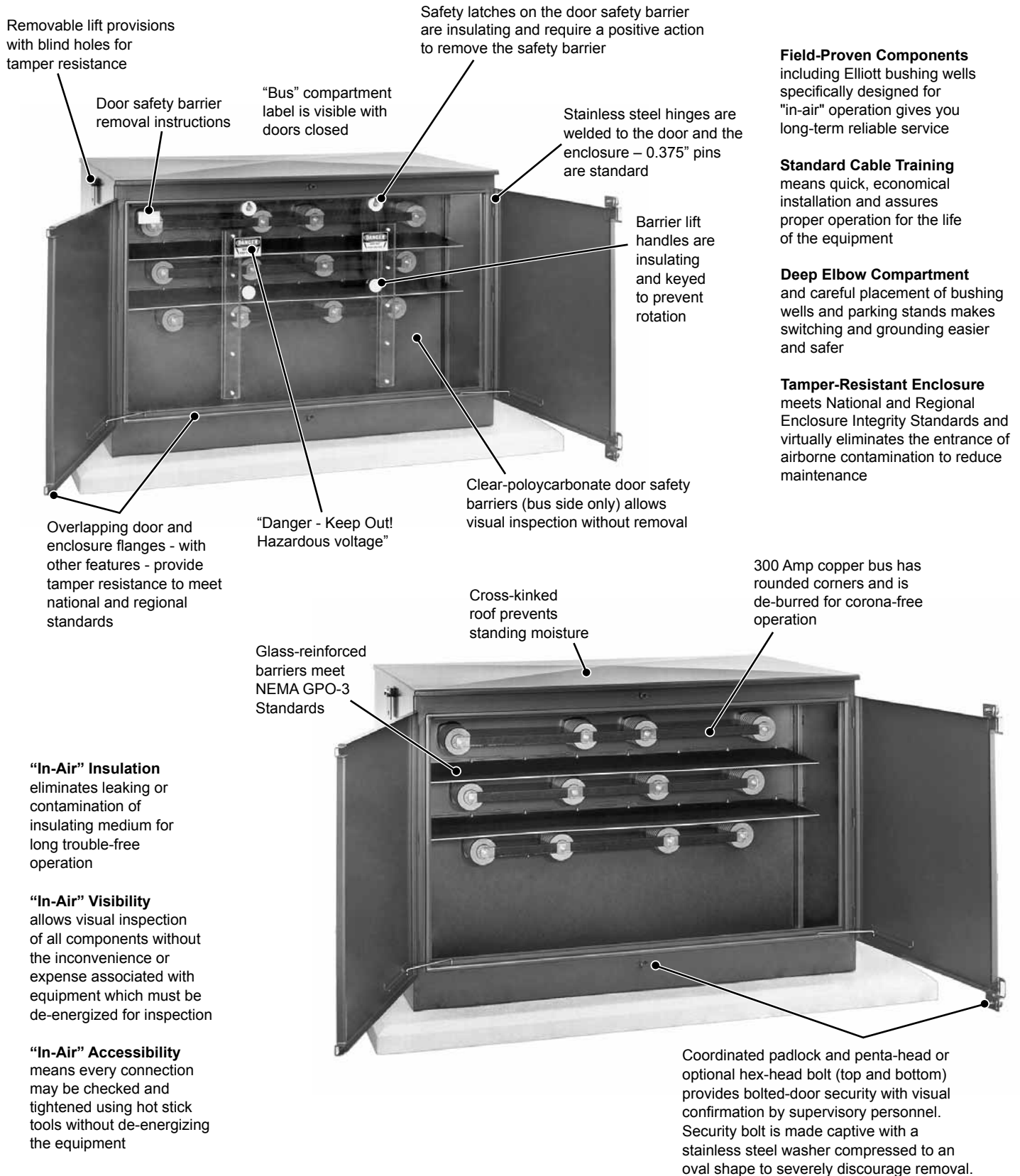

Removable lift provisions with blind holes for tamper resistance

Door safety barrier removal instructions

"Bus" compartment label is visible with doors closed

Safety latches on the door safety barrier are insulating and require a positive action to remove the safety barrier

Stainless steel hinges are welded to the door and the enclosure - 0.375" pins are standard

Field-Proven Components including Elliott bushing wells specifically designed for "in-air" operation gives you long-term reliable service

Standard Cable Training means quick, economical installation and assures proper operation for the life of the equipment

Deep Elbow Compartment and careful placement of bushing wells and parking stands makes switching and grounding easier and safer

Tamper-Resistant Enclosure meets National and Regional Enclosure Integrity Standards and virtually eliminates the entrance of airborne contamination to reduce maintenance

Barrier lift handles are insulating and keyed to prevent rotation

Overlapping door and enclosure flanges - with other features - provide tamper resistance to meet national and regional standards

"Danger - Keep Out! Hazardous voltage"

Clear-polycarbonate door safety barriers (bus side only) allows visual inspection without removal

300 Amp copper bus has rounded corners and is de-burred for corona-free operation

Cross-kinked roof prevents standing moisture

Glass-reinforced barriers meet NEMA GPO-3 Standards

"In-Air" Insulation eliminates leaking or contamination of insulating medium for long trouble-free operation

"In-Air" Visibility allows visual inspection of all components without the inconvenience or expense associated with equipment which must be de-energized for inspection

"In-Air" Accessibility means every connection may be checked and tightened using hot stick tools without de-energizing the equipment

Coordinated padlock and penta-head or optional hex-head bolt (top and bottom) provides bolted-door security with visual confirmation by supervisory personnel. Security bolt is made captive with a stainless steel washer compressed to an oval shape to severely discourage removal.

Standard Cable Training

The Source Isolated Safefront Cable Switching Stations shown in this Bulletin were designed to cable train for easy operation when the cables enter the cable switching station in conduit and when the cables are direct buried. The need to design for different types of cable entrance is eliminated. In addition, "A" phase cables are longer than "B" phase cables and "B" phase cables are longer than "C" phase cables to reduce the possibility of switching error. Common bushing well locations provide the advantage of standard cable training and pad dimensions for all circuits. Cable Switching Stations with one circuit arrangement can be replaced by cable switching stations with a different circuit arrangement and the existing cables need not be re-terminated. The equipment plate is punched to accommodate the installation of additional bushing wells and adapter plates cover the mounting holes not in use. Bushing wells can be added or deleted in the field using only standard tools. There is no need to drill or punch holes when modification is required. Generous space is provided at every parking stand to allow use of a parking or feed-thru accessory. Installation as shown on the recommended Cable Training drawings (in this bulletin) assures your operator they can perform all switching operations.

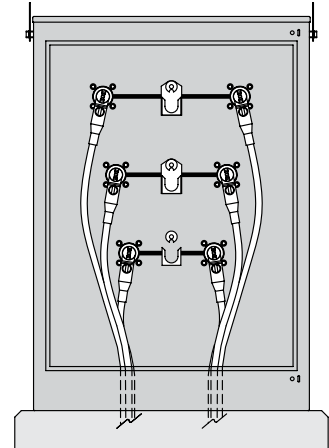

Selecting Switching Stations

The Safefront Cable Switching Stations shown in the circuit diagrams below are rated 21.1/36.6 kV Grounded Wye Maximum design. Dimension drawings and recommended cable training for each design can be found on pages 4 through 21 of this bulletin. The continuous current rating of the copper bus is 300 amperes. The continuous current rating of the bushing well is 200 amps with an eight hour overload rating of 300 amps. Elliott Air-Insulated Bushing Wells are designed for "in-air" operation and accept Elastimold® and other 35 kV class (200 Amp small loadbreak interface No. 2) IEEE Standard loadbreak bushing inserts and elbow terminators. All loadbreak or loadmake operations must be accomplished with the loadbreak elbow terminators. Two ground connectors, which accept #6 through #2/0 cable, are included and installed as shown by the drawings.

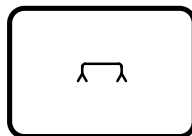

EPME-35-120-E2

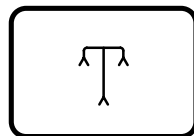

EPME-35-130-E2

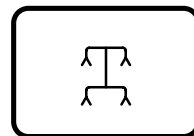

EPME-35-140-E2

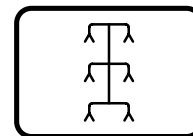

EPME-35-160-E2

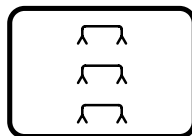

EPME-35-320S-E2

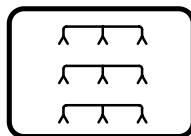

EPME-35-330S-E2

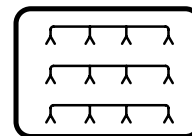

EPME-35-340S-E2

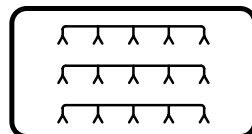

EPME-35-350S-E2

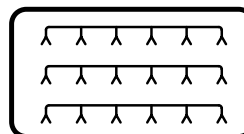

EPME-35-360S-E2

Safefront (elbow-terminated) Cable Switching stations are available for 600 and 1250 amperes and voltage ratings including 35 kV. If you do not find a model to fit your needs, please contact our representative or the factory.

Cable Training and Anchor Bolt Locations

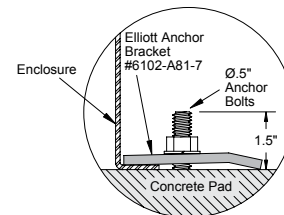
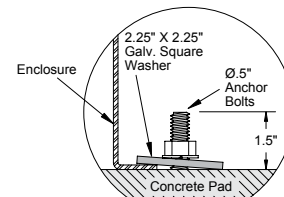
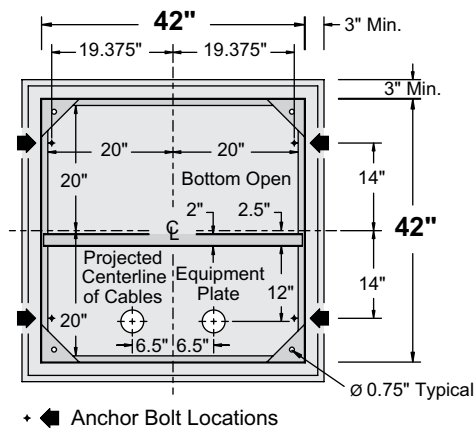
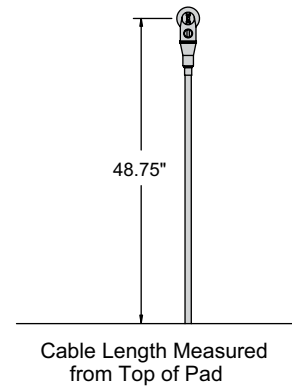
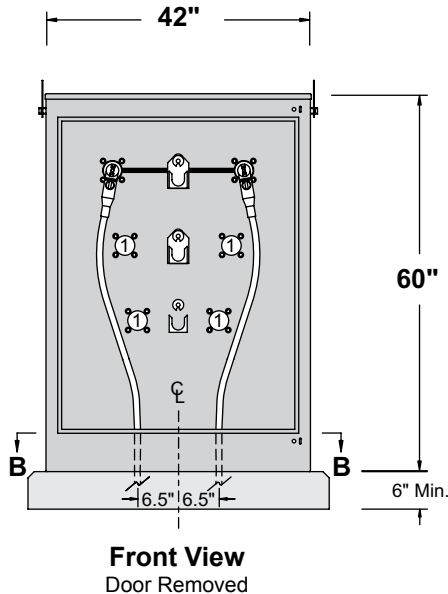

① Bushing wells may be added if circuit requirements change - see page 24 in this bulletin.

EPME-35-120-E2

Non-Fusible
 200-Amp Elliott Bushing Wells

When additional cable terminating space is required, a 66" high enclosure can be supplied to increase cable terminating space by 6". To order a 66" high enclosure, suffix the catalog number "-66H".

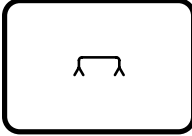

Single Phase – Two Ways Per Phase

200 Amp Elliott Air-Insulated Bushing Wells
 21.1 kV Max Design
 150 kV BIL

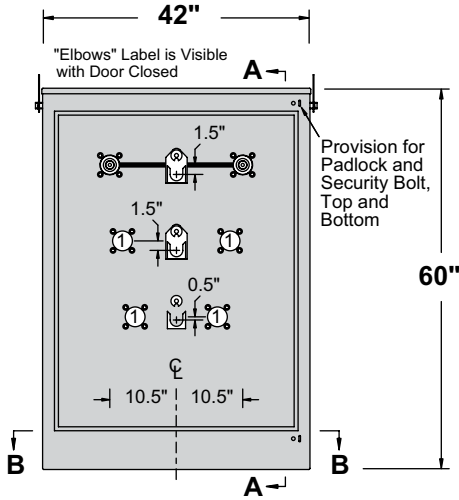

Front View
 Door Removed

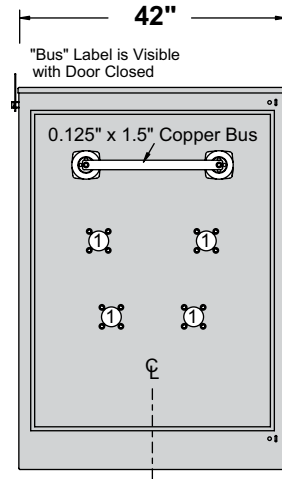

Rear View
 Door & Door Safety Barrier Removed

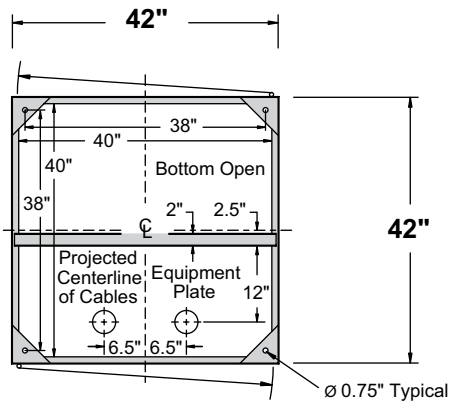

Section BB

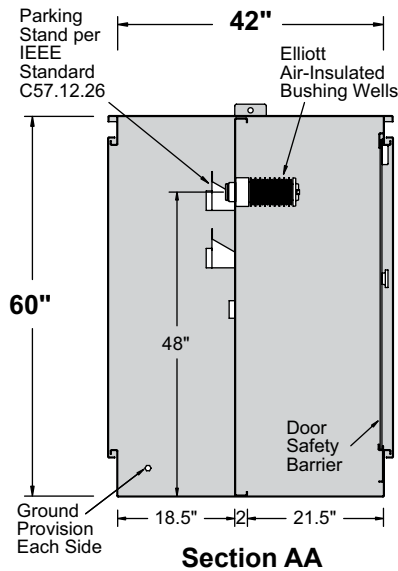

Section AA

① Bushing wells may be added if circuit requirements change - see page 24 in this bulletin.

EPME-35-120-E2	Non-Fusible 200-Amp Elliott Bushing Wells
-----------------------	--

When additional cable terminating space is required, a 66" high enclosure can be supplied to increase cable terminating space by 6". To order a 66" high enclosure, suffix the catalog number "-66H".

Cable Training and Anchor Bolt Locations

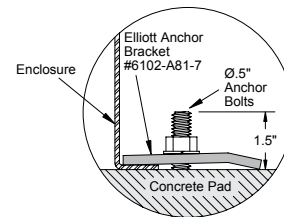
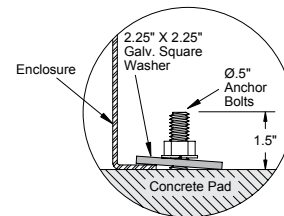
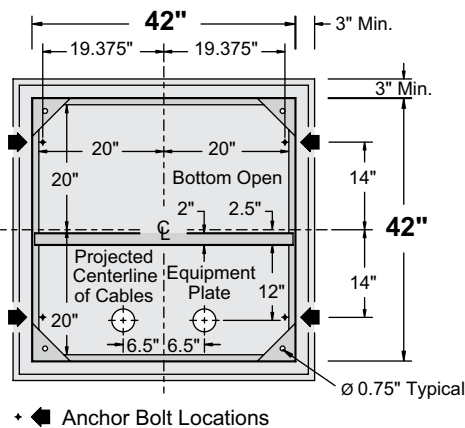
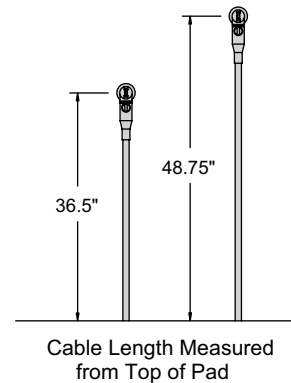
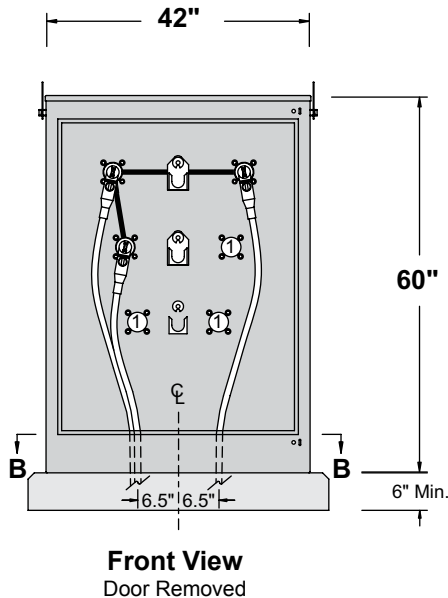

① Bushing wells may be added if circuit requirements change - see page 24 in this bulletin.

EPME-35-130-E2	Non-Fusible 200-Amp Elliott Bushing Wells
-----------------------	--

When additional cable terminating space is required, a 66" high enclosure can be supplied to increase cable terminating space by 6". To order a 66" high enclosure, suffix the catalog number "-66H".



Single Phase – Three Ways Per Phase

200 Amp Elliott Air-Insulated Bushing Wells
 21.1 kV Max Design
 150 kV BIL

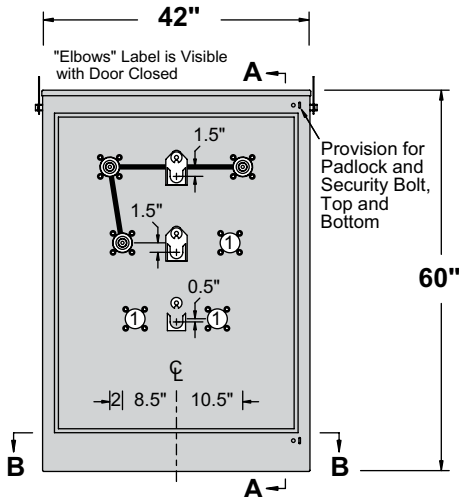

Front View
 Door Removed

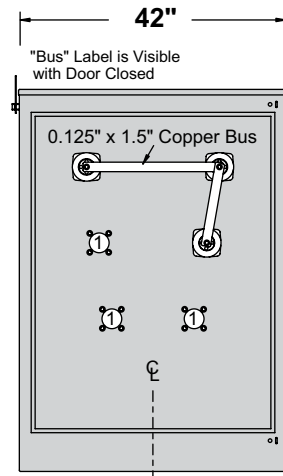

Rear View
 Door & Door Safety Barrier Removed

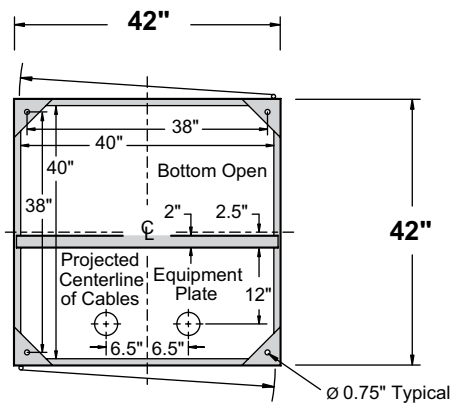

Section BB

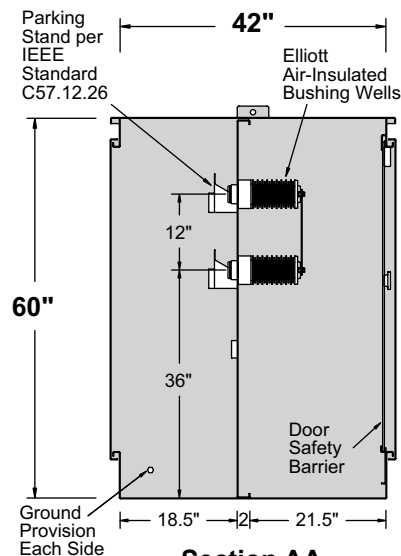

Section AA

① Bushing wells may be added if circuit requirements change - see page 24 in this bulletin.

EPME-35-130-E2

Non-Fusible
 200-Amp Elliott Bushing Wells

When additional cable terminating space is required, a 66" high enclosure can be supplied to increase cable terminating space by 6". To order a 66" high enclosure, suffix the catalog number "-66H".

Cable Training and Anchor Bolt Locations

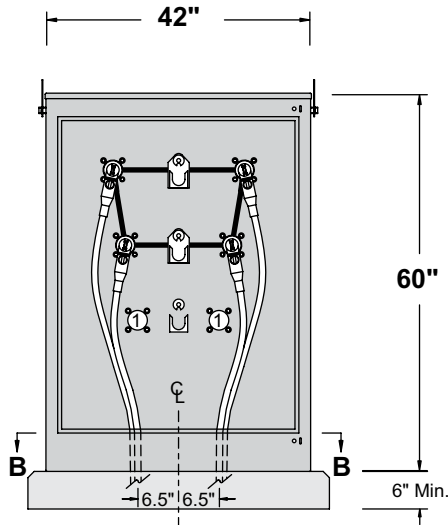

Front View
 Door Removed

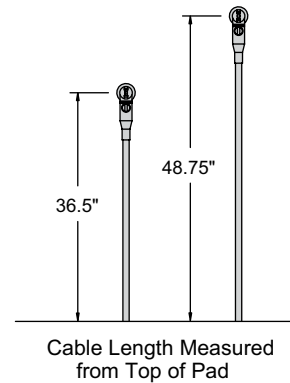

Cable Length Measured from Top of Pad

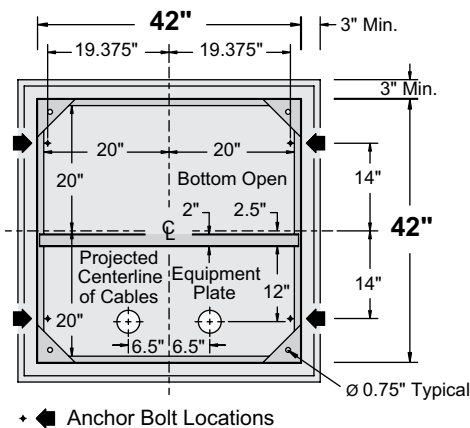

+ ◀ Anchor Bolt Locations

Section BB
 and Typical Pad Dimensions

① Bushing wells may be added if circuit requirements change - see page 24 in this bulletin.

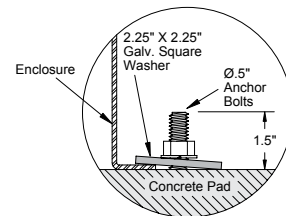

Alternate #1

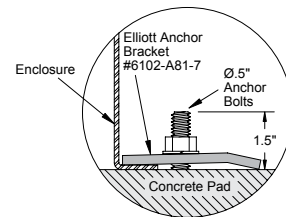

Alternate #2

EPME-35-140-E2

Non-Fusible
 200-Amp Elliott Bushing Wells

When additional cable terminating space is required, a 66" high enclosure can be supplied to increase cable terminating space by 6". To order a 66" high enclosure, suffix the catalog number "-66H".



Single Phase – Four Ways Per Phase

200 Amp Elliott Air-Insulated Bushing Wells
 21.1 kV Max Design
 150 kV BIL

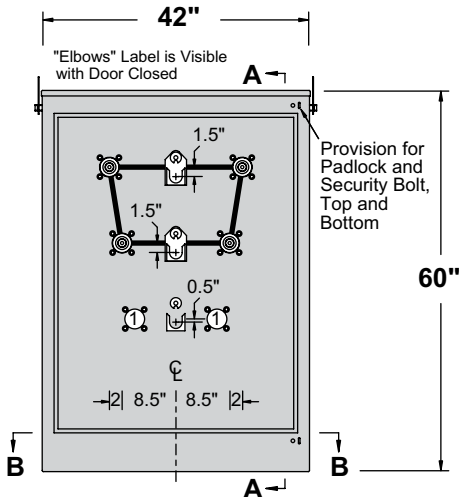

Front View
 Door Removed

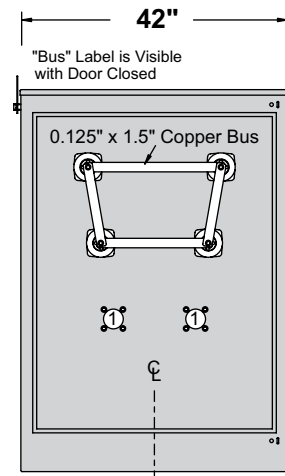

Rear View
 Door & Door Safety Barrier Removed

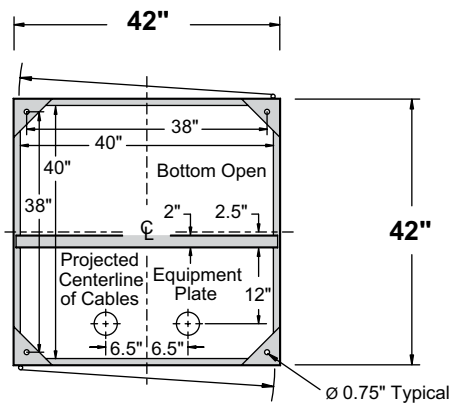

Section BB

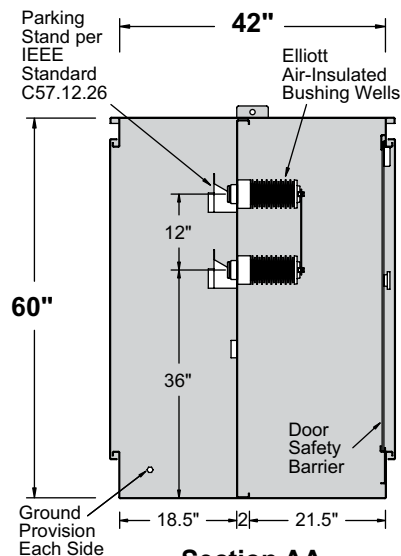

Section AA

① Bushing wells may be added if circuit requirements change - see page 24 in this bulletin.

EPME-35-140-E2

Non-Fusible
 200-Amp Elliott Bushing Wells

When additional cable terminating space is required, a 66" high enclosure can be supplied to increase cable terminating space by 6". To order a 66" high enclosure, suffix the catalog number "-66H".

Cable Training and Anchor Bolt Locations

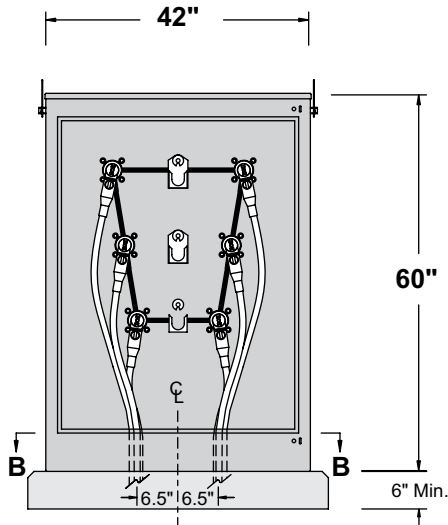

Front View
 Door Removed

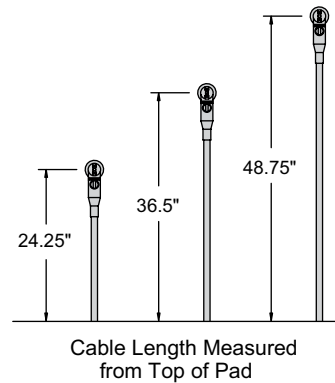

Cable Length Measured from Top of Pad

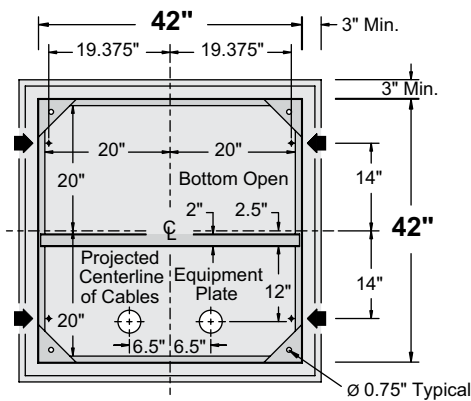

+ * Anchor Bolt Locations

Section BB
 and Typical Pad Dimensions

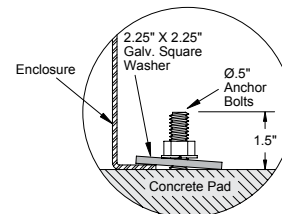

Alternate #1

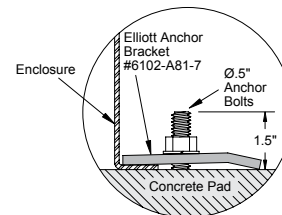

Alternate #2

EPME-35-160-E2

Non-Fusible
 200-Amp Elliott Bushing Wells

When additional cable terminating space is required, a 66" high enclosure can be supplied to increase cable terminating space by 6". To order a 66" high enclosure, suffix the catalog number "-66H".

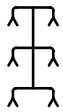

Single Phase – Six Ways Per Phase

200 Amp Elliott Air-Insulated Bushing Wells
 21.1 kV Max Design
 150 kV BIL

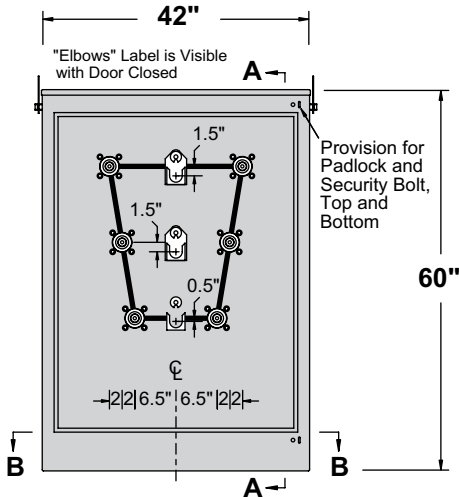

Front View
 Door Removed

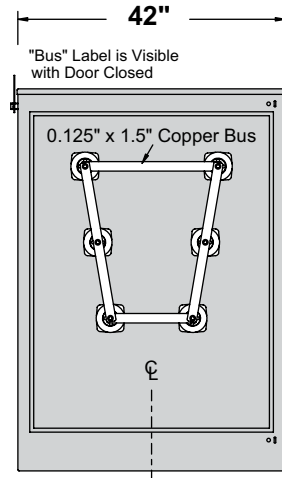

Rear View
 Door & Door Safety Barrier Removed

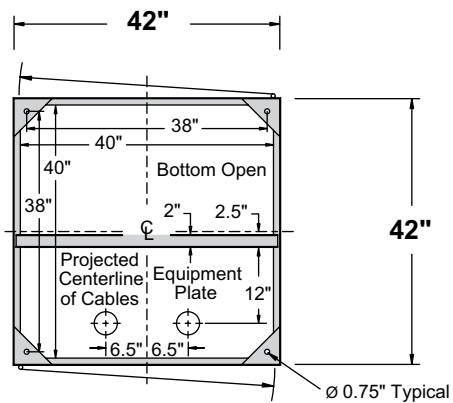

Section BB

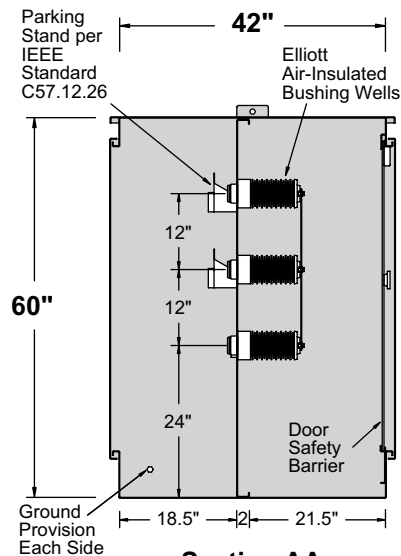

Section AA

EPME-35-160-E2

Non-Fusible
 200-Amp Elliott Bushing Wells

When additional cable terminating space is required, a 66" high enclosure can be supplied to increase cable terminating space by 6". To order a 66" high enclosure, suffix the catalog number "-66H".

Cable Training and Anchor Bolt Locations

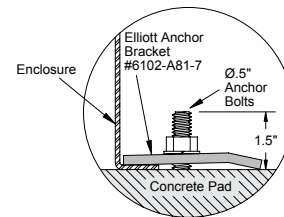
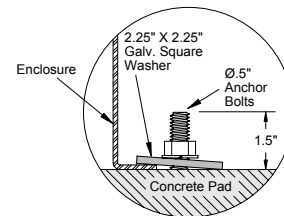
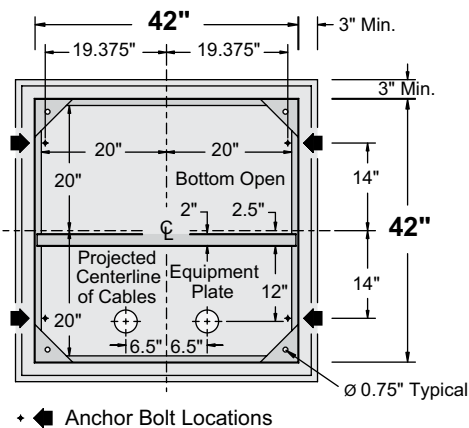
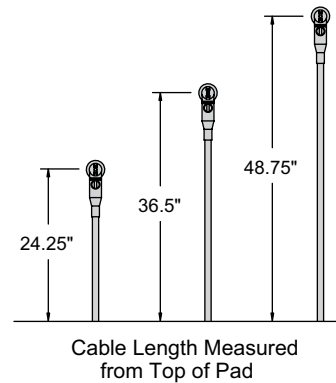
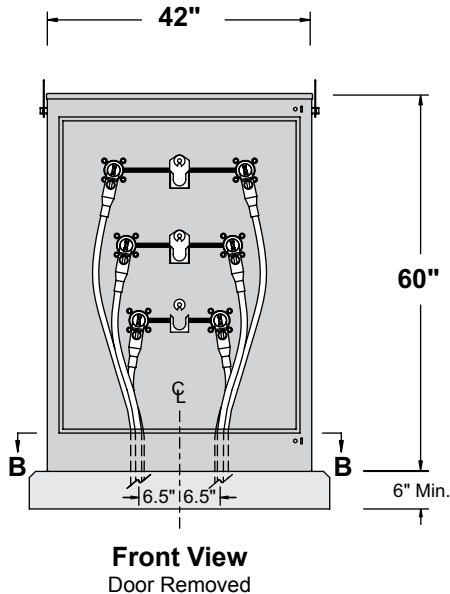

EPME-35-320S-E2 Non-Fusible
 200-Amp Elliott Bushing Wells

When additional cable terminating space is required, a 66" high enclosure can be supplied to increase cable terminating space by 6". To order a 66" high enclosure, suffix the catalog number "-66H".



Three Phase – Two Ways Per Phase

200 Amp Elliott Air-Insulated Bushing Wells

21.1/36.6 kV Grounded Wye Max Design

150 kV BIL

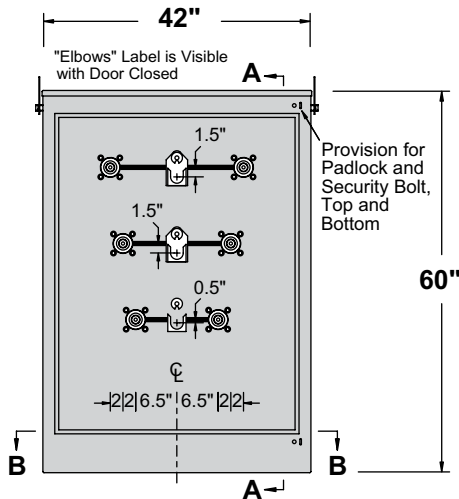

Front View
Door Removed

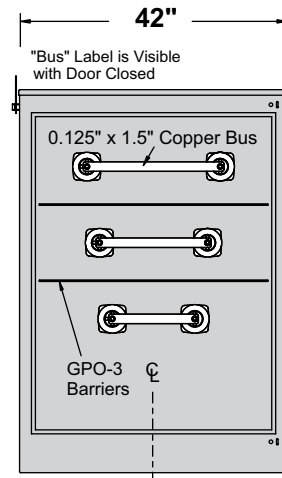

Rear View
Door & Door Safety Barrier Removed

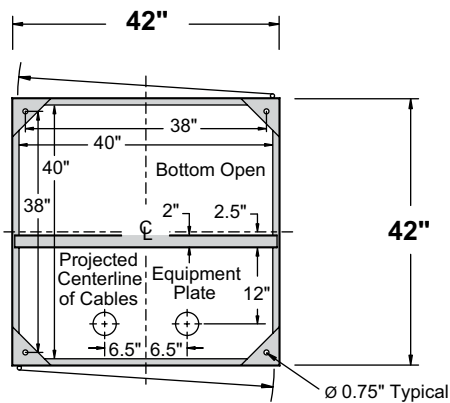

Section BB

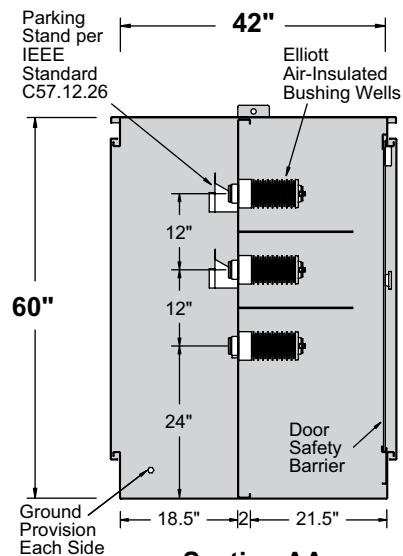

Section AA

EPME-35-320S-E2

Non-Fusible
200-Amp Elliott Bushing Wells

When additional cable terminating space is required, a 66" high enclosure can be supplied to increase cable terminating space by 6". To order a 66" high enclosure, suffix the catalog number "-66H".

Cable Training and Anchor Bolt Locations

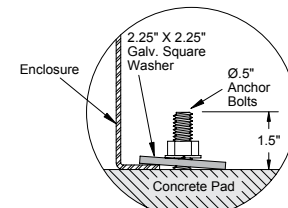
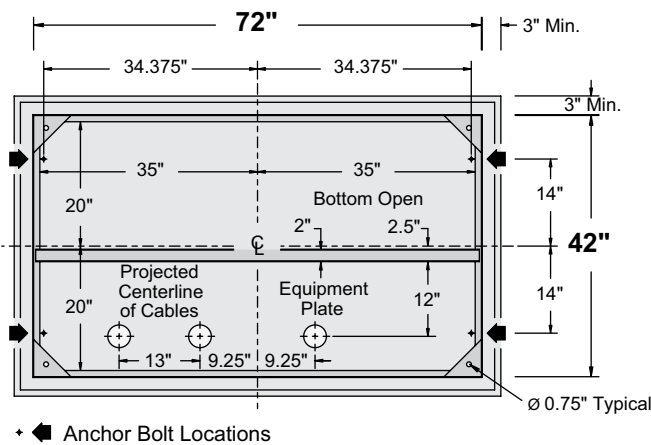
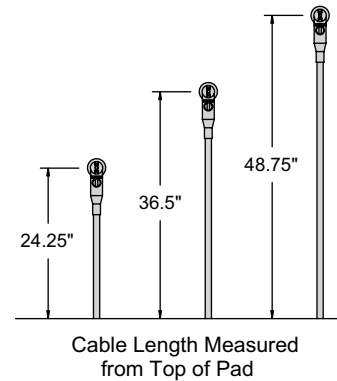
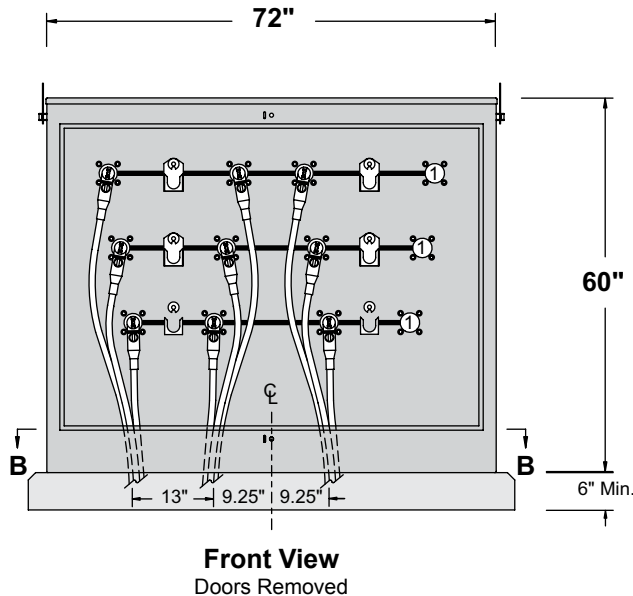

Alternate #1

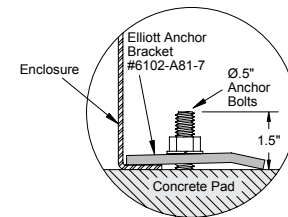

Alternate #2

Section BB
 and Typical Pad Dimensions

① Bushing wells may be added if circuit requirements change - see page 24 in this bulletin.

EPME-35-330S-E2	Non-Fusible 200-Amp Elliott Bushing Wells
------------------------	--

When additional cable terminating space is required, a 66" high enclosure can be supplied to increase cable terminating space by 6". To order a 66" high enclosure, suffix the catalog number "-66H".

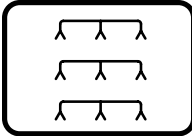

Three Phase – Three Ways Per Phase

200 Amp Elliott Air-Insulated Bushing Wells
 21.1/36.6 kV Grounded Wye Max Design
 150 kV BIL

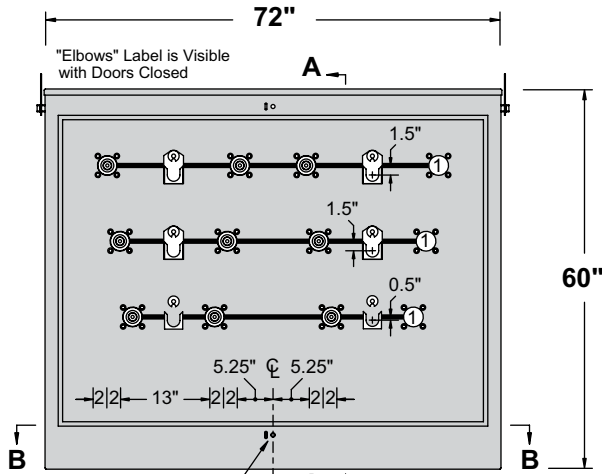

Front View
 Doors Removed

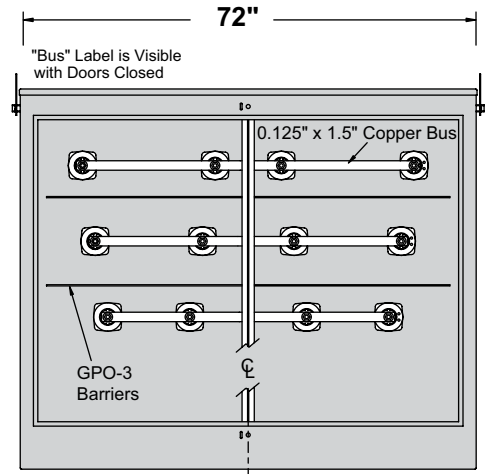

Rear View
 Doors & Door Safety Barriers Removed

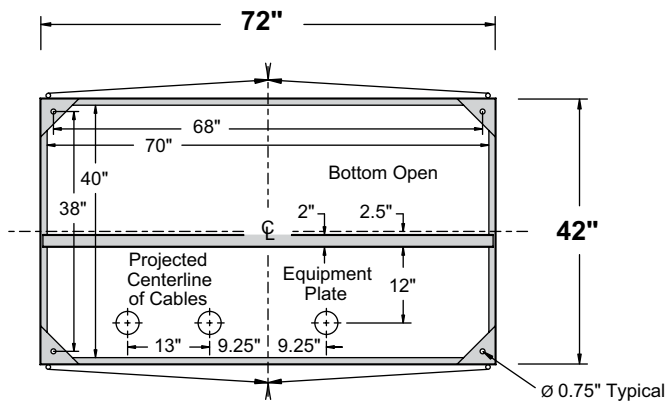

Section BB

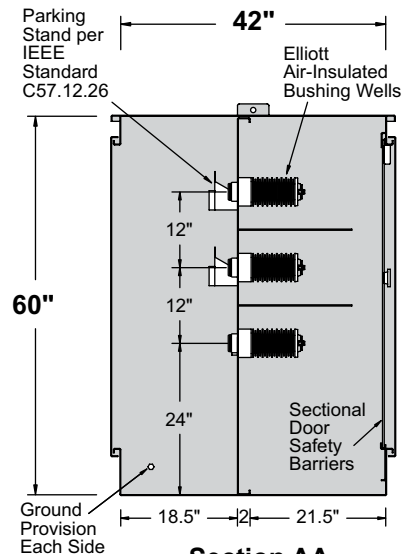

Section AA

① Bushing wells may be added if circuit requirements change - see page 24 in this bulletin.

EPME-35-330S-E2	Non-Fusible 200-Amp Elliott Bushing Wells
------------------------	--

When additional cable terminating space is required, a 66" high enclosure can be supplied to increase cable terminating space by 6". To order a 66" high enclosure, suffix the catalog number "-66H".

Cable Training and Anchor Bolt Locations

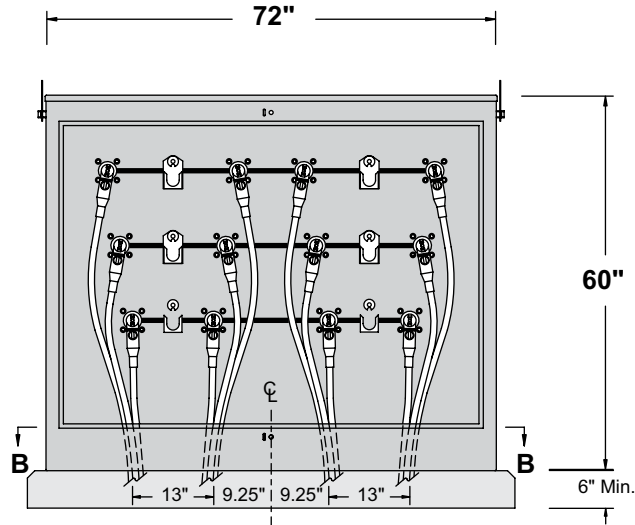

Front View
 Doors Removed

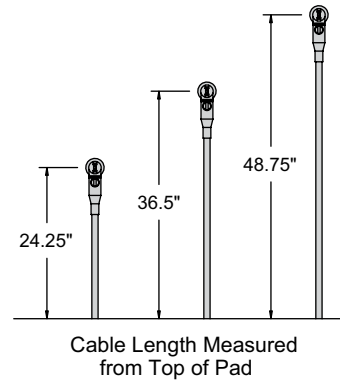

Cable Length Measured from Top of Pad

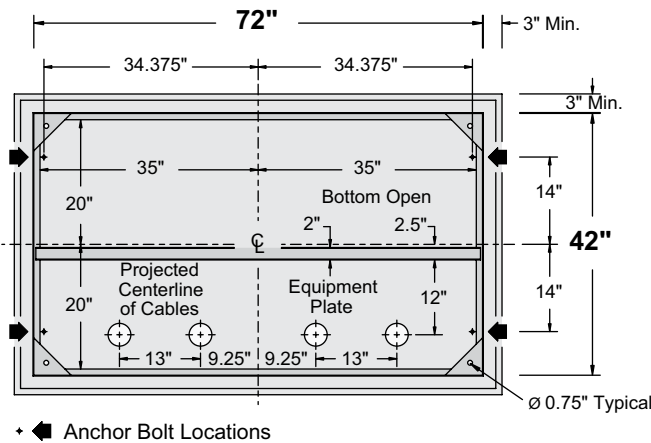

Anchor Bolt Locations

Section BB
 and Typical Pad Dimensions

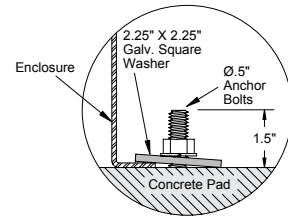

Alternate #1

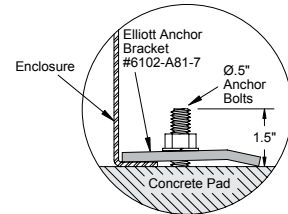

Alternate #2

EPME-35-340S-E2 Non-Fusible
 200-Amp Elliott Bushing Wells

When additional cable terminating space is required, a 66" high enclosure can be supplied to increase cable terminating space by 6". To order a 66" high enclosure, suffix the catalog number "-66H".

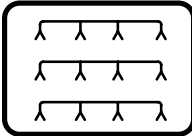

Three Phase – Four Ways Per Phase

200 Amp Elliott Air-Insulated Bushing Wells
 21.1/36.6 kV Grounded Wye Max Design
 150 kV BIL

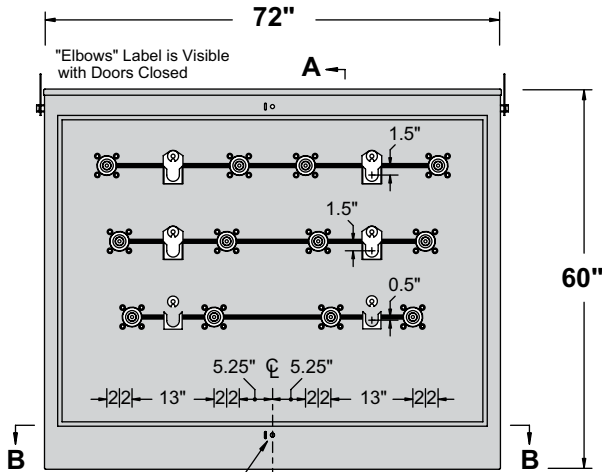

Front View
 Doors Removed

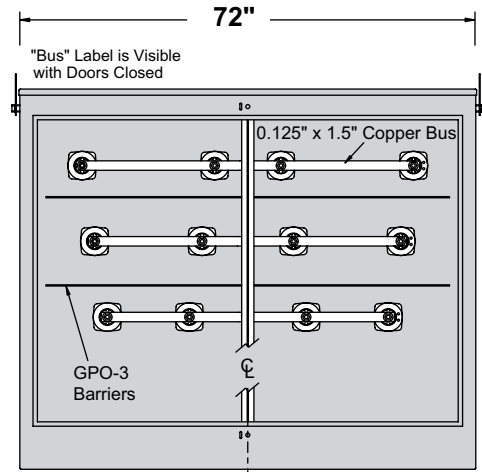

Rear View
 Doors & Door Safety Barriers Removed

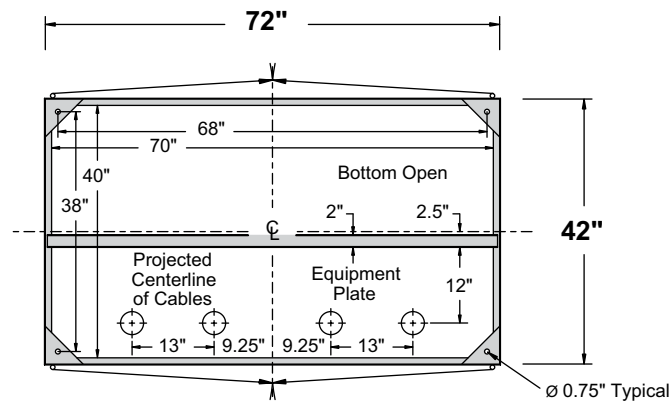

Section BB

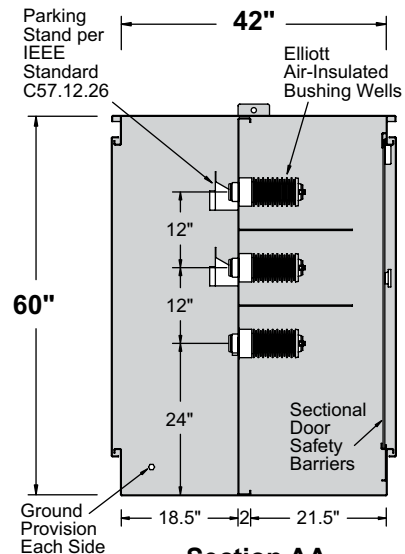

Section AA

EPME-35-340S-E2

Non-Fusible
 200-Amp Elliott Bushing Wells

When additional cable terminating space is required, a 66" high enclosure can be supplied to increase cable terminating space by 6". To order a 66" high enclosure, suffix the catalog number "-66H".

Cable Training and Anchor Bolt Locations

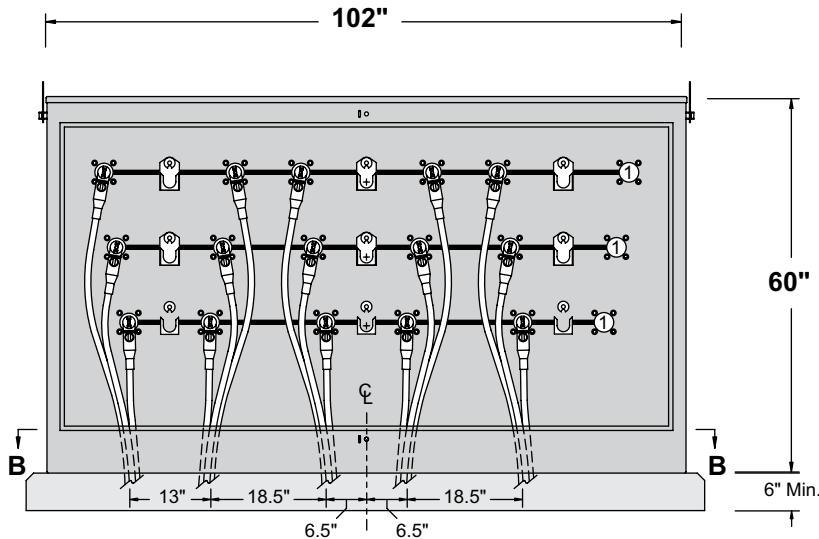

Front View
 Doors Removed

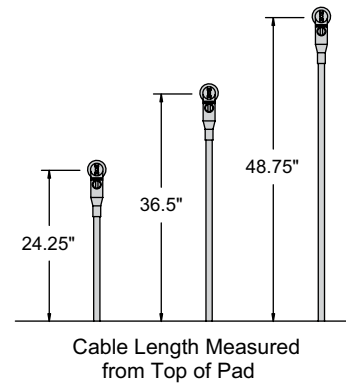

Cable Length Measured from Top of Pad

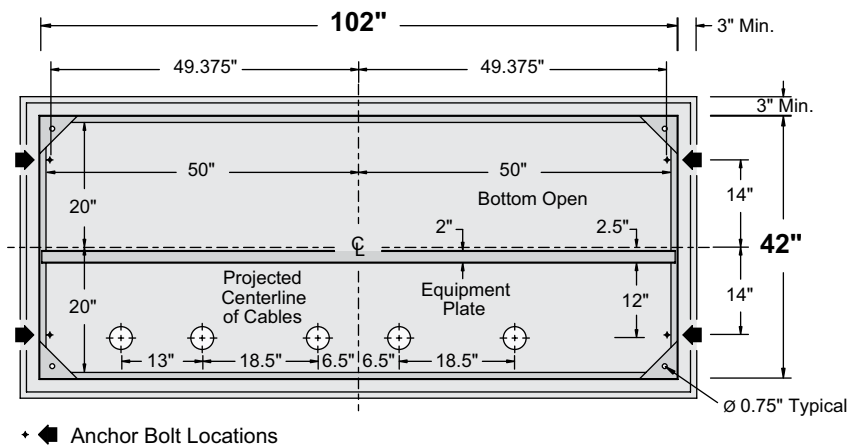

Anchor Bolt Locations

Section BB
 and Typical Pad Dimensions

① Bushing wells may be added if circuit requirements change - see page 24 in this bulletin.

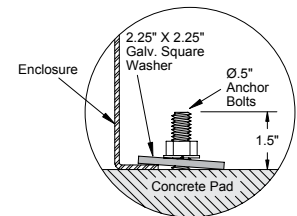

Alternate #1

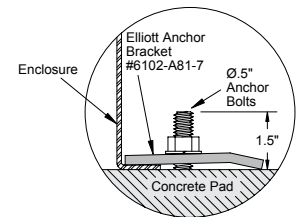

Alternate #2

EPME-35-350S-E2

Non-Fusible
 200-Amp Elliott Bushing Wells

When additional cable terminating space is required, a 66" high enclosure can be supplied to increase cable terminating space by 6". To order a 66" high enclosure, suffix the catalog number "-66H".

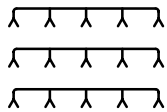

Three Phase – Five Ways Per Phase

200 Amp Elliott Air-Insulated Bushing Wells
 21.1/36.6 kV Grounded Wye Max Design
 150 kV BIL

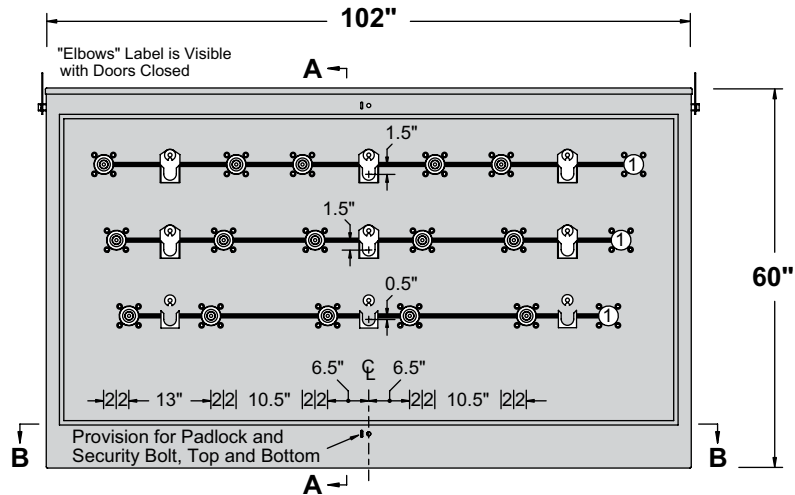

Front View
 Doors Removed

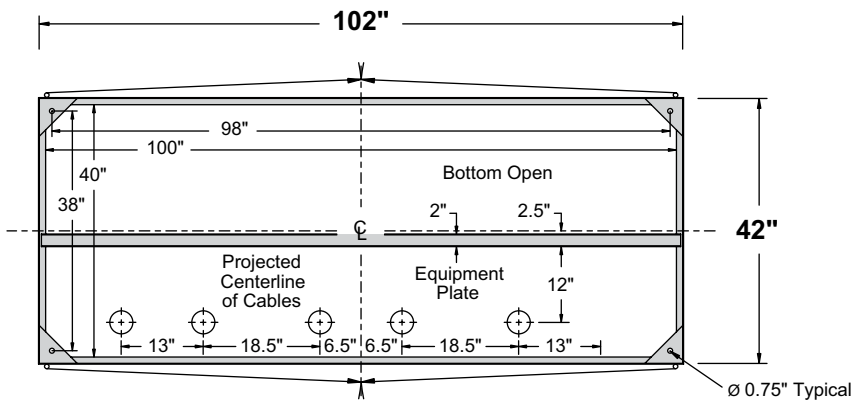

Section BB

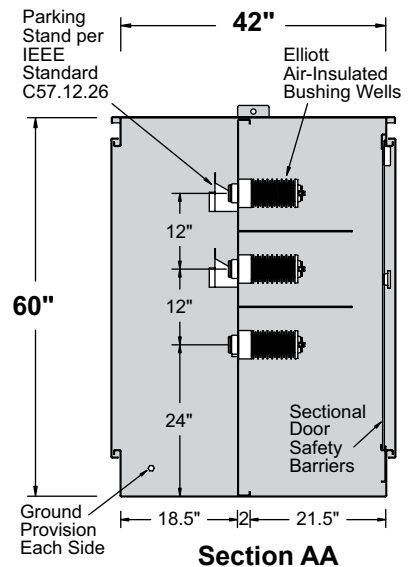

Section AA

① Bushing wells may be added if circuit requirements change - see page 24 in this bulletin.

EPME-35-350S-E2

Non-Fusible
 200-Amp Elliott Bushing Wells

When additional cable terminating space is required, a 66" high enclosure can be supplied to increase cable terminating space by 6". To order a 66" high enclosure, suffix the catalog number "-66H".

Cable Training and Anchor Bolt Locations

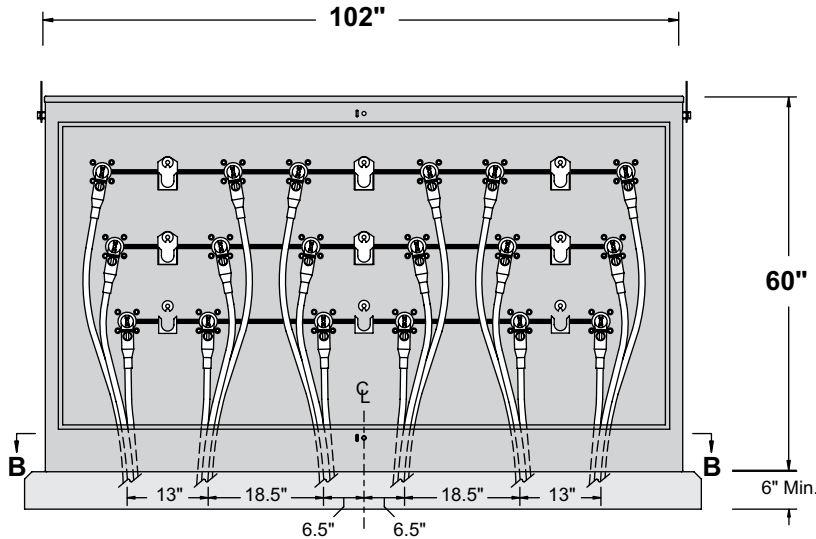

Front View
 Doors Removed

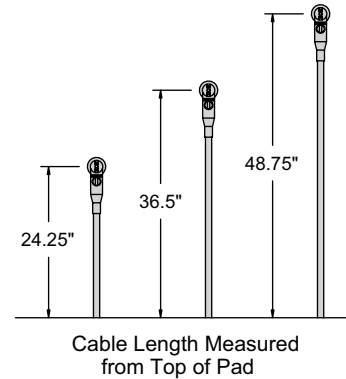

Cable Length Measured from Top of Pad

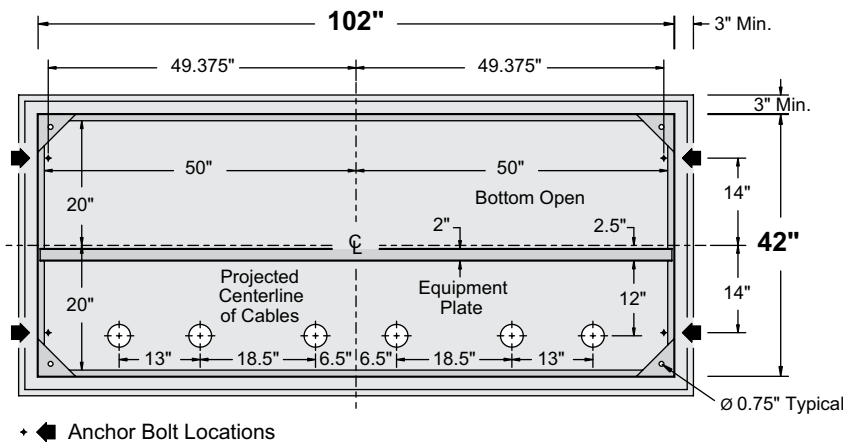

Anchor Bolt Locations

Section BB
 and Typical Pad Dimensions

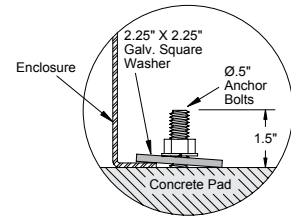

Alternate #1

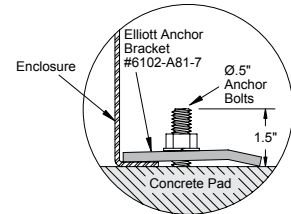

Alternate #2

EPME-35-360S-E2 Non-Fusible
 200-Amp Elliott Bushing Wells

When additional cable terminating space is required, a 66" high enclosure can be supplied to increase cable terminating space by 6". To order a 66" high enclosure, suffix the catalog number "-66H".

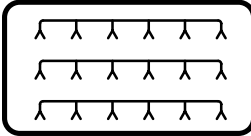

Three Phase – Six Ways Per Phase

200 Amp Elliott Air-Insulated Bushing Wells
 21.1/36.6 kV Grounded Wye Max Design
 150 kV BIL

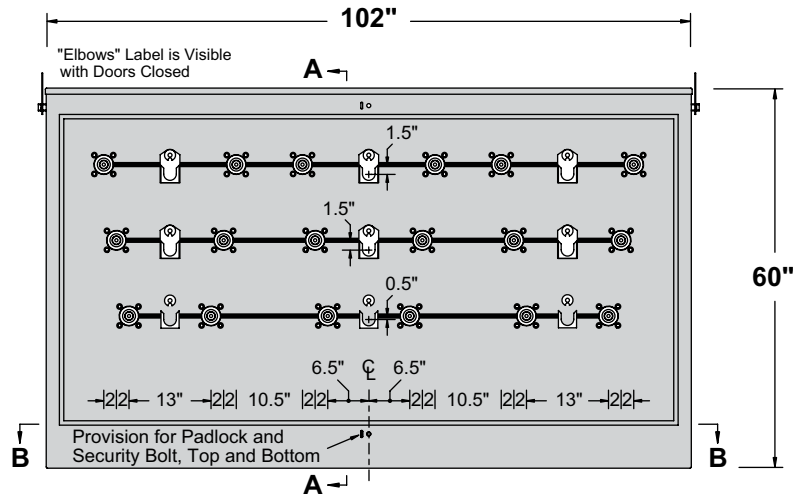

Front View
 Doors Removed

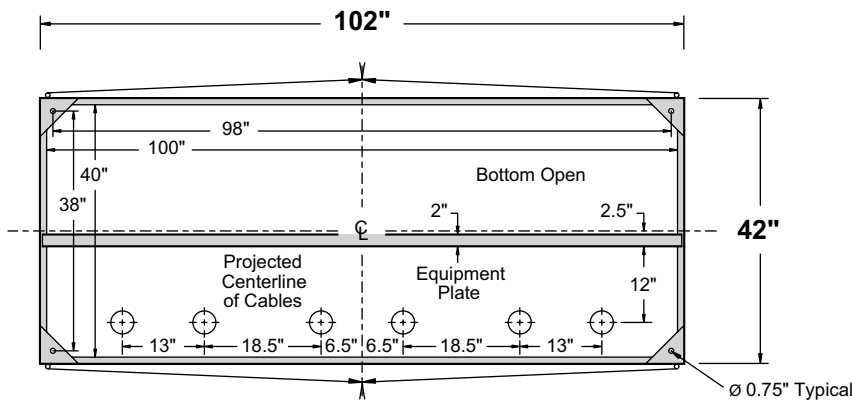

Section BB

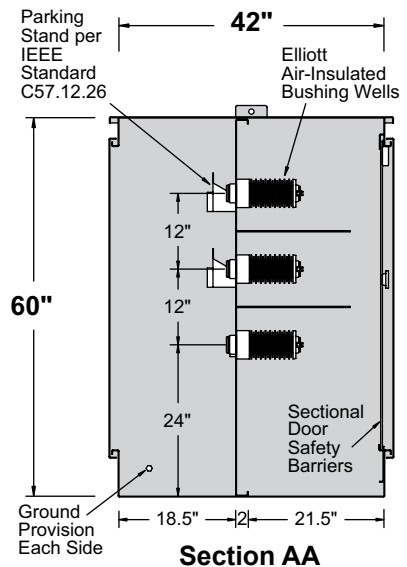

Section AA

EPME-35-360S-E2

Non-Fusible
 200-Amp Elliott Bushing Wells

When additional cable terminating space is required, a 66" high enclosure can be supplied to increase cable terminating space by 6". To order a 66" high enclosure, suffix the catalog number "-66H".

Typical Specification - Page 1 of 2

General

The cable switching station shall be 35 kV class, 150 kV BIL, 200 ampere continuous current, suitable for use on 21.1/36.6 kV grounded wye max design systems. The switching station shall be constructed for connection to the utility system with loadbreak separable insulated connectors as described in IEEE Standard 386 Fig. 3 (Elastimold® or other approved equal). Separable insulated connectors and loadbreak inserts shall be supplied by the user. The switching station shall be designed for and contain bus in a compartment separated from the elbow compartment by a steel equipment plate. Separate access shall be provided for each compartment. A door safety barrier shall be provided inside the door(s) on the bus compartment as recommended in IEEE Standard C2 (National Electrical Safety Code) Rule 381G. Tamper resistance shall meet the Enclosure Security requirements of IEEE Standard C57.12.28 (Pad-Mounted Equipment—Enclosure Integrity). Together, the tamper resistance and the door safety barrier shall resist unauthorized entry, protect authorized and unauthorized persons, and provide positive safety features when installed in areas accessible to the general public. The cable switching station shall be constructed for outdoor installation in areas subject to heavy precipitation and in areas with windblown contamination. The equipment shall be “air-insulated” and completely assembled prior to shipment.

Enclosure Construction

The enclosure shall be tamper-resistant, all-welded construction utilizing 11-gauge minimum sheet steel. Corner plates and braces shall be used as necessary to assure rigidity. The enclosure top shall be cross-kinked to provide watershed and rigidity. The enclosure shall be open bottom with a 1-inch flange inside, all around. Separate compartments shall be provided for cable termination and for buswork—each compartment equipped with its own individual access door(s) furnished with a stainless steel door holder that will latch the door open 100 degrees and 140 degrees and resist accidental closing. The equipment plate separating the two compartments shall be full length, constructed with 11-gauge minimum sheet steel braced to assure rigidity when operating the elbows. Doors shall be provided with provisions for padlocking and a recessed penta-head (or hex-head) security bolt to prevent unauthorized entry (coordinated to prevent installation of the padlock until the security bolt is tightened *when closing the door(s)* and to prevent a wrench from operating the security bolt until the padlock is removed *when opening the door(s)*). The security bolt shall be made captive with a stainless steel washer compressed to an oval shape to severely discourage removal. Hinges shall be stainless steel (with stainless steel pins not less than 0.3125-inch diameter) and shall be welded to both the enclosure and the door(s) to maintain door alignment for the life of the equipment. The

enclosure shall be nonventilated to minimize the entrance of airborne contamination, insects, rodents or reptiles. The protective finish shall include necessary grinding, cleaning and phosphatizing, two-component rust-inhibiting epoxy primer and a Pad-Mount Green two-component polyurethane top coat finish (Munsell color 7GY 3.29/1.5). The primer and top coat shall be electronically monitored during application to insure proper ratio and mixing of each component. Total average thickness of paint (after curing) shall be not less than 5 mils. The protective coating shall meet the Enclosure Coating System requirements of IEEE Standard C57.12.28 (Pad-Mounted Equipment—Enclosure Integrity). Removable lift provisions, adequate to withstand handling with normal utility equipment, shall be provided on the outside of the enclosure. Threaded openings for lift provision bolts shall be blind holes to prevent the entrance of wire or other foreign objects into the enclosure when lift provisions are removed.

Bushings and Terminals

Bushings shall be 200 ampere Elliott #1102-235B, 35 kV class (21.1 kV to ground) Air-Insulated Bushing Wells, 150 kV BIL, per IEEE Standard 386-2016 Fig. 3 (Interface 3: a 200 A Bushing Well Interface) *for use with 21.1/36.6 kV separable insulated connectors* (Elastimold® or other approved equal). The bushing wells shall be pressure-molded cycloaliphatic epoxy with a 0.75-inch diameter copper conductor on the “air-insulated” side that is drilled and tapped 0.375-inch – 16UNC x 1-inch deep to provide direct connection of the bus and/or live parts. Leakage distance from the apparatus connection end of the bushing well to ground shall be not less than 40 inches to assure trouble-free operation in a wet and/or contaminated environment. Integral shielding shall be provided to eliminate partial discharge caused by off-center mounting and mounting holes that may have sharp edges or burrs. Bushing wells shall mount in a 3.125-inch diameter opening and bolt in place to allow field replacement with standard tools. The bushing well mounting bolts shall be self-locking stainless steel serrated-flange hex-head bolts that “cut” through the enclosure protective finish to ground the integral shielding of each bushing well. The head of one or more of the mounting bolts for each bushing well shall include a 0.156-inch diameter hole to provide a connection to ground for the loadbreak insert shielding ground wire as recommended by separable insulated connector manufacturers. To assure adequate strength for apparatus support, the bushing well shall withstand a minimum cantilever loading of 600 pounds for five minutes without damage. The bushing well interface shall be free of all voids, holes and heat sinks to assure proper mating with separable insulated connectors. Each bushing well shall be tested in free air, mounted in a grounded steel plate not less than 10 inches x 10 inches, with a bushing well plug (Eaton’s Cooper Power Systems #IBWP225 or equal) installed in the well interface to

Typical Specification - Page 2 of 2

accurately simulate operating conditions (*gas or liquid dielectric in the interface shall not be acceptable for this test*). Each bushing well shall meet the requirements for 35 kV devices in accordance with the test values of IEEE Standard 386 (latest revision), including 100 percent production testing.

Bus

Bus shall be copper with all burrs and sharp corners removed prior to installation. Positive pressure shall be assured by use of stainless steel fasteners and lock washers at all connection points. All connections shall provide direct contact of current-carrying parts and shall not depend on current transfer through fastener thread-to-thread contact. Electrical components shall be "air-insulated" and positioned to allow visual inspection of all internal connections and components *without removing the clear-polycarbonate door safety barrier*, de-energizing or removing the equipment from service.

Barriers

Phase and ground barriers shall be provided to assure correct phase-to-phase and phase-to-ground clearances for proper operation at rated voltage. These barriers shall be glass-reinforced polyester (NEMA GPO-3 class material) not less than 0.1875-inch thick.

A removable insulating barrier with a "DANGER – Keep Out! – Hazardous voltage" sign, Elliott #7203-D2003-309, shall be located inside the door(s) on the bus compartment as recommended in Rule 381G of IEEE Standard C2 (National Electrical Safety Code). *When the enclosure width exceeds 70 inches*, the removable insulating barrier shall be divided to provide *sectional door safety barriers* with reduced size for secure handling. The door safety barrier(s) shall be constructed of 0.25-inch clear polycarbonate (Lexan or equal) and *shall completely close the door opening* and be provided with a nonconductive safety latch requiring a positive action to remove the barrier. Handles and other hardware extending through this door safety barrier shall be nonconductive material. Handles shall be keyed to prevent rotation for secure handling. *Complete visual inspection of the internal components shall be possible without removing the door safety barrier.*

Grounding Provisions

Two high-conductivity bronze eyebolt-type ground lugs, which accept #6 through #2/0 copper conductor, shall be installed in the cable terminating compartment (located on each side of the door opening in an accessible position).

Accessory Equipment

Stainless steel parking stands shall be provided in the quantity required to allow use of feed-thru bushings, parking bushings and grounding bushings. The parking stands for the

upper two phases shall extend 3 inches from the equipment plate per IEEE Standard C57.12.26 for improved switching operations. The parking stands shall be welded in place, in a position to allow the use of hot-line tools for installation of feed-thru bushings, etc. The parking stands shall be *unpainted* (except welds shall be painted) *to provide a ground* for feed-thru bushings and other devices that may be placed into the parking stands. *Keyed retainers* shall be welded above each parking stand *to prevent slipping or accidental removal* of portable devices such as feed-thru bushings, etc.

A corrosion proof nameplate with permanent thermal transfer printing shall be installed inside one door on the elbow compartment. It shall be located at the top corner farthest from the elbows when the door is open. The nameplate will provide Type of Equipment, Model Number, Amps Continuous, kV Maximum, BIL, Serial Number, Job Number, Date Manufactured and Weight of Equipment.

Bus connections between bushings shall be displayed (on the cable side of the equipment plate) using 0.5-inch-wide solid orange-color pressure-sensitive vinyl tape. The resulting schematic shall clearly indicate the circuit arrangement of the cable switching station. The schematic shall be legible at a distance of six feet or more.

When enclosures have more than one door (or other access provision) each access shall be labeled in near proximity of the locking provisions with a pressure-sensitive vinyl label using letters not less than 0.375-inch nor more than 0.625-inch high. The label shall indicate the type of equipment behind the access (elbows, fuses, bus, etc.).

When specified, four anchor-bolt brackets, Elliott #6102-A81-7 or approved equal, shall be supplied with each cable switching station to provide a means of clamping the equipment to the concrete pad.

Packaging

Each cable switching station shall be bolted to a solid-top wood pallet (to prevent the forks of a forklift truck from entering the open bottom of the equipment) to prevent hidden damage. The equipment shall be wrapped with 0.125-inch thick polyethylene foam or other suitable material to minimize damage to the finish during shipment.

Drawings

When specified, drawings shall be furnished for each cable switching station that include:

- 1) enclosure dimensions and location of components.
- 2) proposed cable-training layout and dimensions.
- 3) proposed pad dimensions and location of anchor bolts.

Bushing Well Installation Instructions

The cable switching stations shown in this bulletin have equipment plates punched to accommodate the installation of additional bushing wells. The extra mounting holes are closed with "bushing-style" insulators or adapter plates. If circuit requirements change, bushing wells can be added or removed to provide the circuit arrangements shown in this bulletin. The mounting hardware used to mount the "bushing-

style" insulator or adapter plate is the same hardware used to install a bushing well. There is no need to drill holes when modification is required.

NOTE: *The cable switching station must be de-energized and grounded in accordance with your company's normal safety procedure before any modifications are made.*

Procedure for Bushing Well Installation

NOTE: *The shipping cap on the bushing well should be left in place to prevent contamination of the interface.*

1. Remove the bus bar.
2. Remove the "bushing-style" insulator or adapter plate from the equipment plate (retain for future use).
3. Install the bushing well into the mounting hole from the bus side.
4. Install the serrated-flange bolts. Bolts should be tightened in a uniform manner applying no more than 90 inch-pounds torque to each bolt. The serrated-flange bolts must "cut" into the mounting plate to provide a connection from the shielding to the grounded equipment mounting plate.
5. Connect the copper bus bar to the bushing well just installed using hardware previously removed.

6. Tighten the bolt on both ends of the bus bar no more than 216 inch-pounds.

IMPORTANT: *Do not energize this bushing well with only the shipping cap in place.* To do so would lead to failure of the bushing well and create a hazard to operating personnel. *This product is designed to be used only when it is mated with an appropriate 35 kV class bushing insert and elbow conforming to the latest revision of IEEE Standard 386.* The bushing insert and elbow should be installed in accordance with the instructions supplied by the connector manufacturer.

