

Heavy-duty 11-gauge steel enclosure is all-welded construction for long life

11-gauge steel equipment plate is rigid for easier elbow operation

Upper parking stands extend 3" per IEEE C57.12.26 for improved switching

Keyed retainers to prevent slipping or accidental removal of portable devices

"Elbows" compartment label is visible with doors closed

Bus and transformer schematic is orange-colored vinyl for high visibility

200 Amp Elliott air-insulated bushing wells accept IEEE Standard inserts and elbows

Bolt head with grounding eye for attachment of insert ground wire

Corrosion proof nameplate is located to provide easy access for the operator

All twelve bushing locations are punched so additional bushings may be field installed when circuit requirements change

Door-holder rods are stainless steel and hold the doors open 100 degrees or 140 degrees

Parking stands are unpainted stainless steel and provide space and grounding for feed-thru and other portable devices

Superlife finish includes phosphatizing, rust-inhibiting epoxy primer and Pad-Mount Green (Munsell 7GY 3.29/1.5) polyurethane top coat - over 5 mils dry

Ground lugs on each wall of the elbow and transformer compartment accept #6 - #2/0 ground cable

Open bottom and extra depth of elbow compartment provides space for use of feed-thru and other portable devices with the doors open and closed

ENCLOSURE OPTIONS:

- 1) 0.125" #5052H32 Aluminum
- 2) 12-gauge #304L Stainless Steel

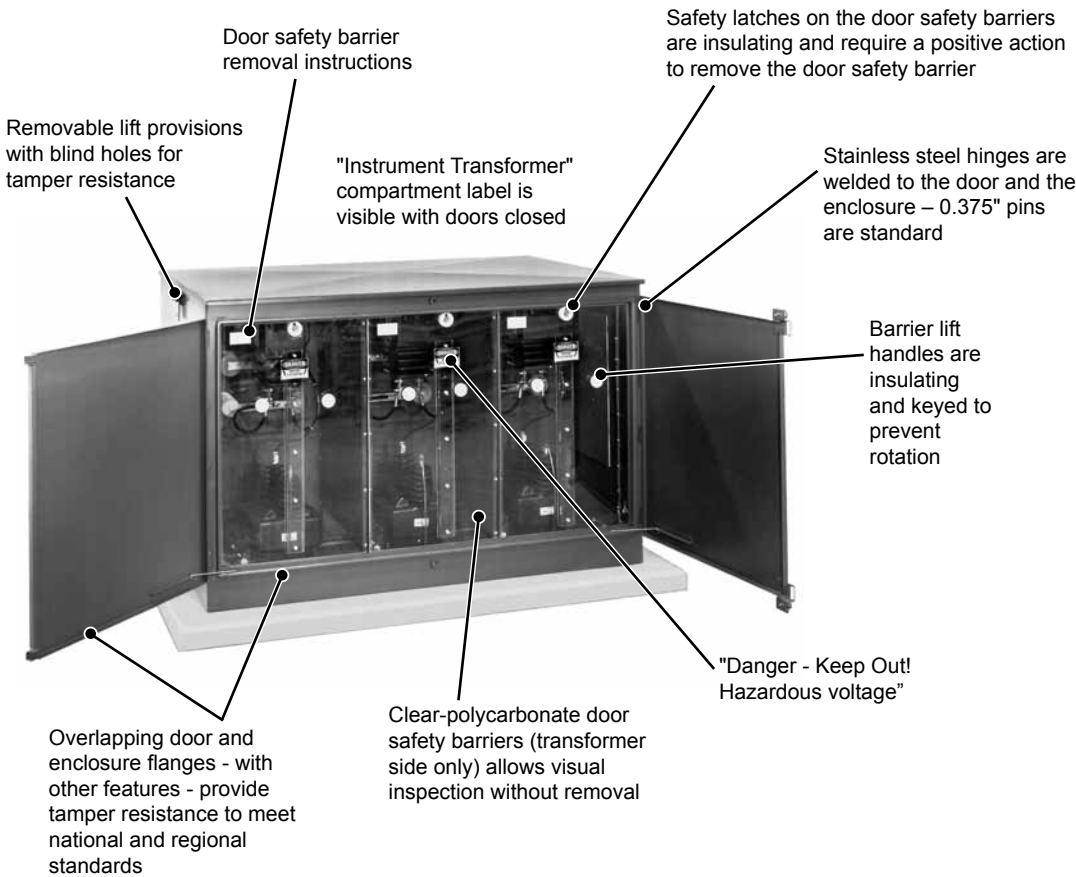

Field-Proven Components including Elliott bushing wells specifically designed for "in-air" operation gives you long-term reliable service

Standard Cable Training means quick, economical installation and assures proper operation for the life of the equipment

Deep Elbow Compartment and careful placement of bushing wells and parking stands makes switching and grounding easier and safer

Tamper-Resistant Enclosure meets National and Regional Enclosure Integrity Standards and virtually eliminates the entrance of airborne contamination to reduce maintenance

"In-Air" Insulation eliminates leaking or contamination of insulating medium for long trouble-free operation

"In-Air" Visibility allows visual inspection of all components without the inconvenience or expense associated with equipment which must be de-energized for inspection

"In-Air" Accessibility means every connection may be checked and tightened using hot-stick tools without de-energizing the equipment

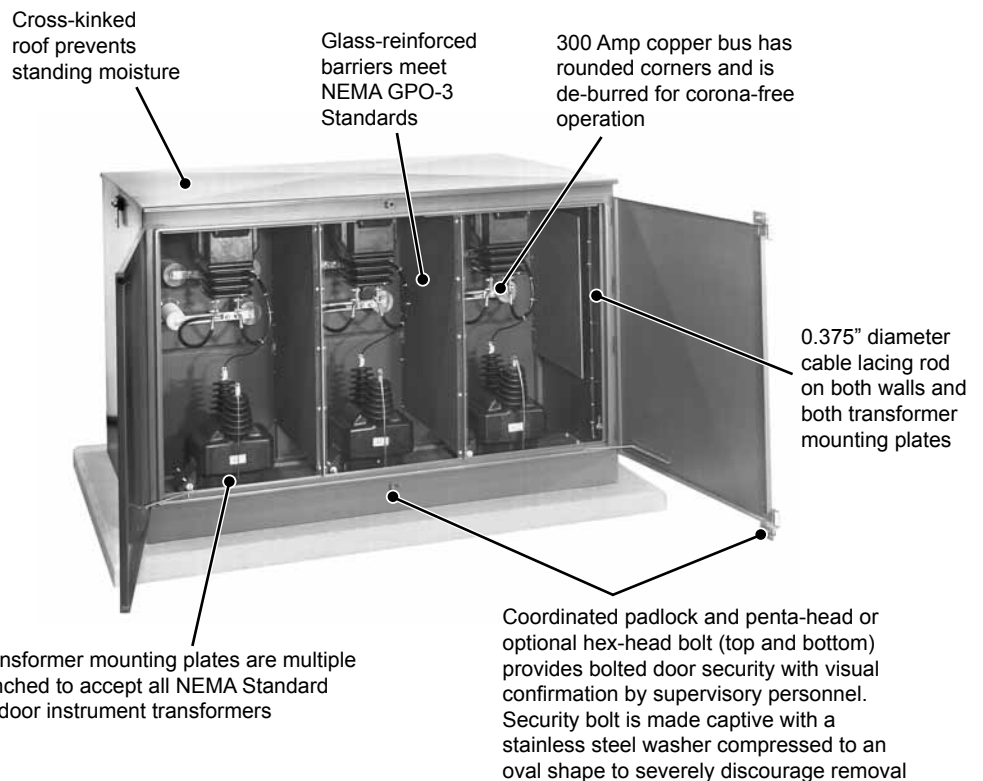

Standard Cable Training

The Phase-Isolated Safefront Primary Metering Stations shown in this Bulletin were designed to employ the cable training shown in the drawings to the right. Common bushing well locations provide the advantages of standard cable training and pad dimensions for all circuits. Metering Stations with one circuit arrangement can be replaced by metering stations with a different circuit arrangement and the existing cables need not be re-terminated. The equipment plate is punched to accept twelve bushing wells with “bushing-style” insulators or adapter plates covering the mounting holes not in use. Bushing wells can be added or removed in the field using only standard tools. There is no need to drill holes when modification is required. The upper row of parking stands are positioned 3 inches out from the equipment plate so cables clear the lower bushing wells and parking stands when the upper elbows are installed in a parking or feed-thru accessory. Lower parking stands are positioned slightly below the bushing wells for easy transfer of elbows to a parking or feed-thru accessory. Generous space is provided at every parking stand to allow use of a parking or feed-thru accessory. Installation as shown on the recommended Cable Training drawings (in this Bulletin) assures your operator they can perform all necessary cable transfer operations.

Selecting Metering Stations

The Safefront Primary Metering Stations shown in the circuit diagrams to the right are rated 15.2/26.3 kV Grounded Wye Maximum design. Dimension drawings and recommended cable training for each design can be found on pages 4 through 11 of this bulletin. The continuous-current rating of the copper bus is 300 amperes. Elliott Air-Insulated Bushings are designed for “in-air” operation and accept Elastimold®, Eaton’s Cooper Power Systems and other 25 kV class IEEE Standard loadbreak bushing inserts and elbow terminators. Each model can be ordered with or without instrument transformers. All loadbreak or loadmake operations must be accomplished with the loadbreak elbow terminators. Four ground connectors, which accept #6 through #2/0 cable, are included and installed as shown by the drawings.

Safefront (elbow-terminated) Primary Metering Stations are available for 200, 600, 900 and 1250 amperes and voltage ratings including 15 kV, 25 kV and 35 kV. If you do not find a model to fit your needs, please contact our representative or the factory.

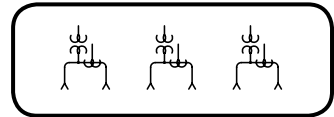
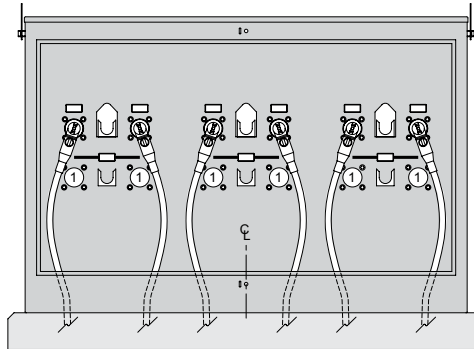

EPM-PMS-25-311P-E2
Pages 4 & 5

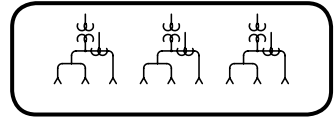
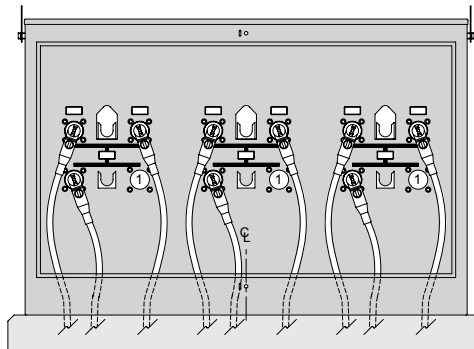

EPM-PMS-25-321P-E2
Pages 6 & 7

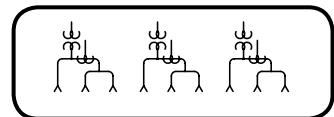
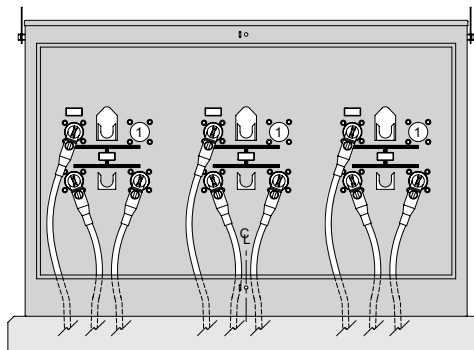

EPM-PMS-25-312P-E2
Pages 8 & 9

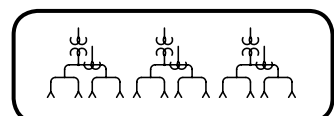
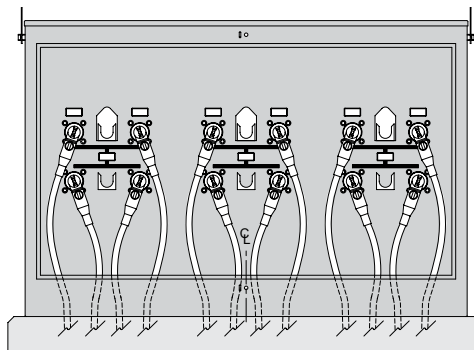

EPM-PMS-25-322P-E2
Pages 10 & 11

① Bushings may be added if circuit requirements change – see page 13 in this bulletin.



25-kV Safefront 200 Amp Primary Metering Station

Pad-Mounted – Outdoor

Bulletin
500-202
Page 4 2018

Cable Training and Anchor Bolt Locations

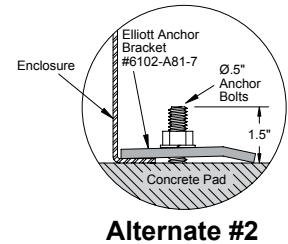
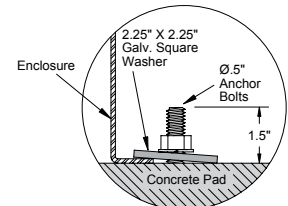
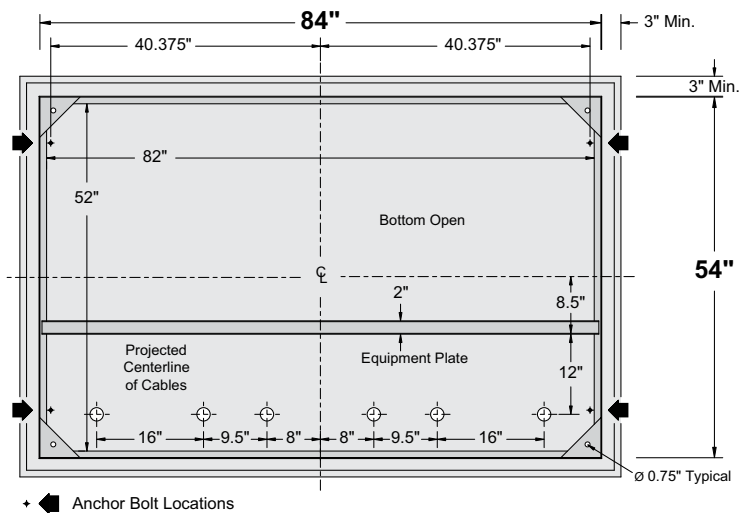
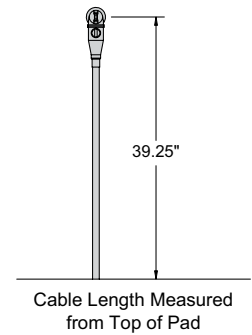
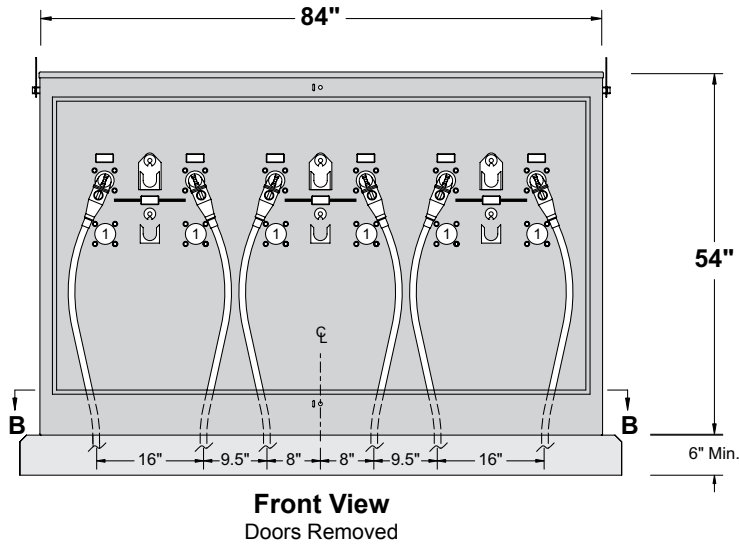

① Bushing wells may be added if circuit requirements change - see page 13 in this bulletin.

EPM-PMS-25-311P-E2	NEMA Standard Outdoor Instrument Transformers
---------------------------	--

Elastimold® is a registered trademark of ABB Asea Brown Boveri Ltd.

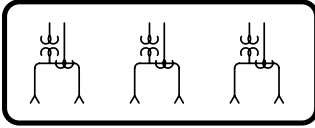

Three Phase – Two Ways per Phase
200 Amp Elliott Air-Insulated Bushing Wells
NEMA Standard Outdoor Instrument Transformers
15.2/26.3 kV Grounded Wye Max Design
60 Hertz, 125 kV BIL

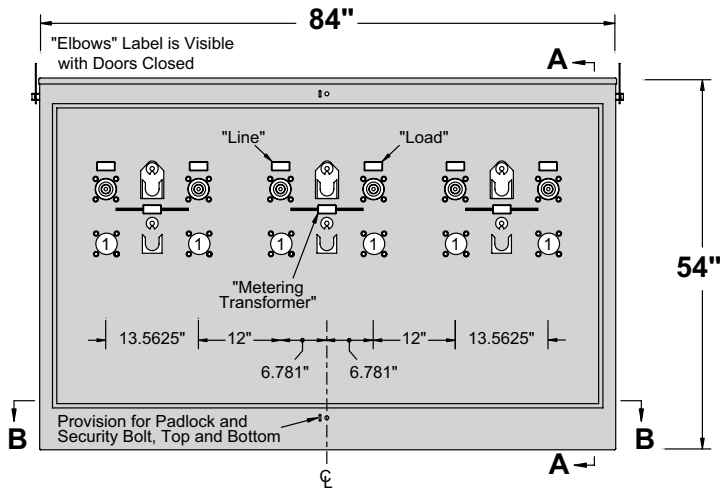

Front View
Doors Removed

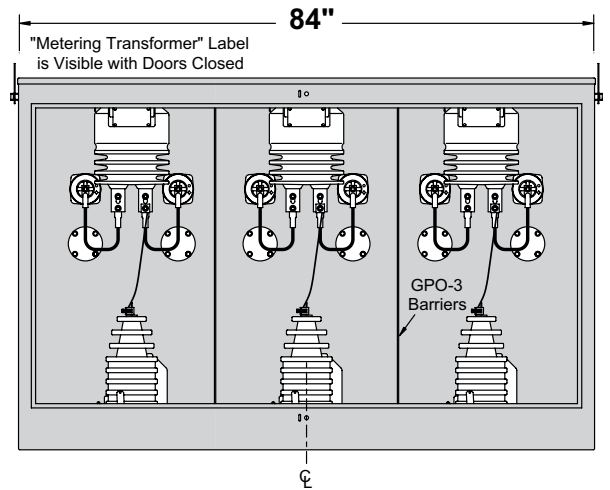

Rear View
Doors & Door Safety Barriers Removed

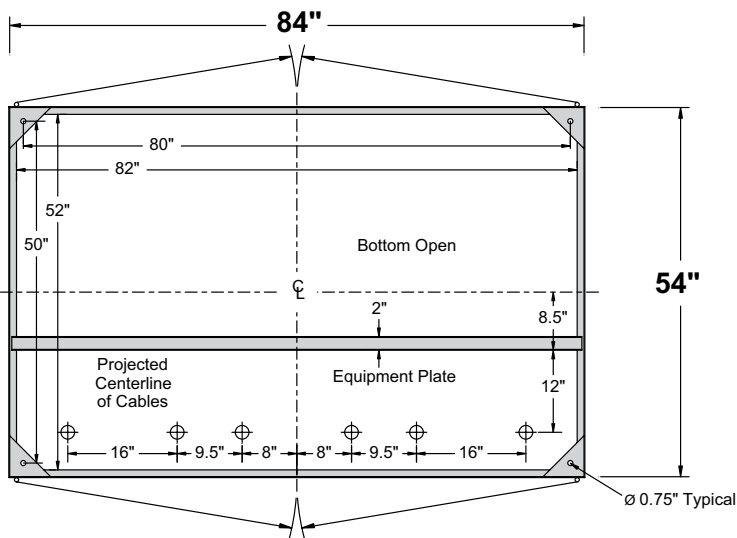

Section BB

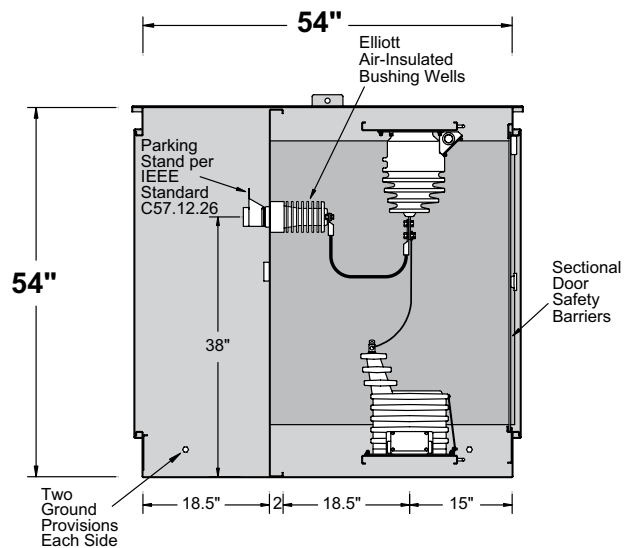

Section AA

① Bushing wells may be added if circuit requirements change - see page 13 in this bulletin.

EPM-PMS-25-311P-E2

NEMA Standard Outdoor Instrument Transformers



25-kV Safefront 200 Amp Primary Metering Station

Pad-Mounted – Outdoor

Bulletin
500-202
Page 6 2018

Cable Training and Anchor Bolt Locations

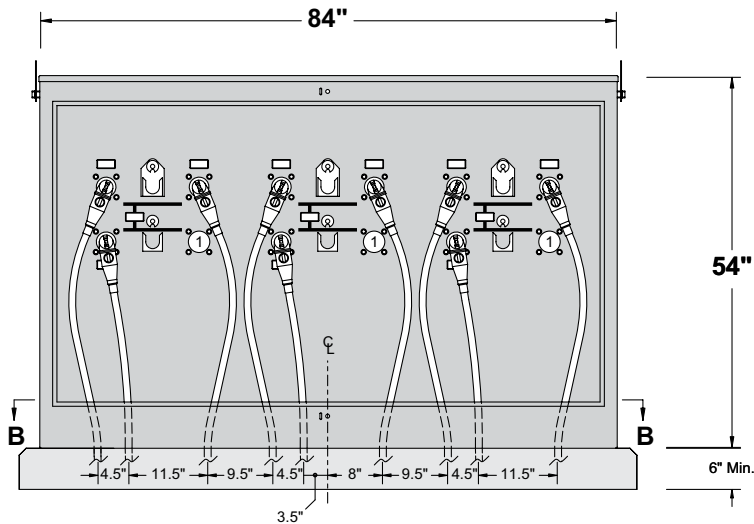

Front View
Doors Removed

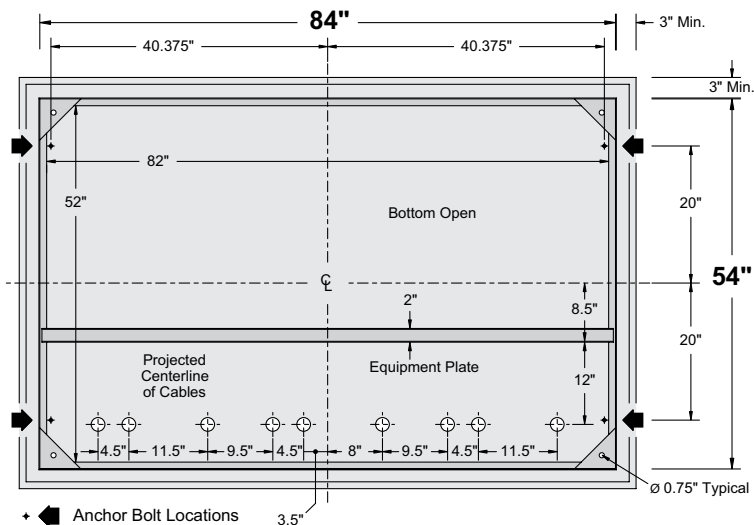
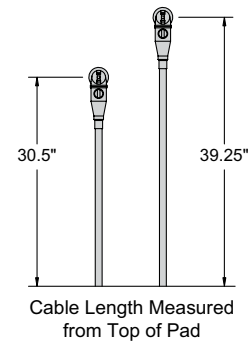

Section BB
and Typical Pad Dimensions

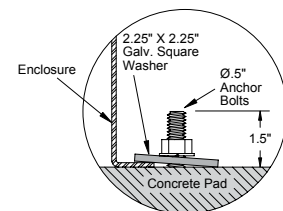

Alternate #1

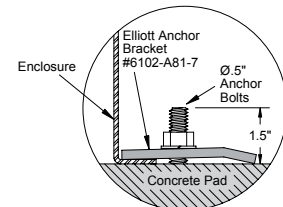

Alternate #2

① Bushing wells may be added if circuit requirements change - see page 13 in this bulletin.

EPM-PMS-25-321P-E2

NEMA Standard Outdoor
Instrument Transformers

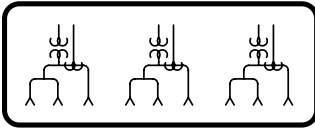

Three Phase – Three Ways per Phase
200 Amp Elliott Air-Insulated Bushing Wells
NEMA Standard Outdoor Instrument Transformers
15.2/26.3 kV Grounded Wye Max Design
60 Hertz, 125 kV BIL

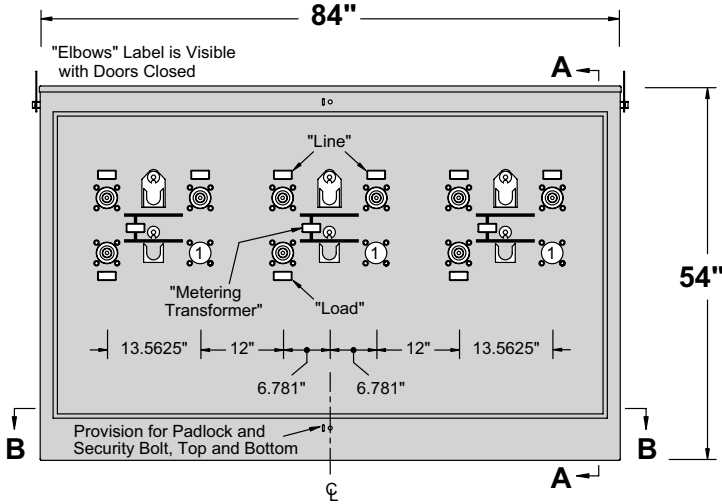

Front View
Doors Removed

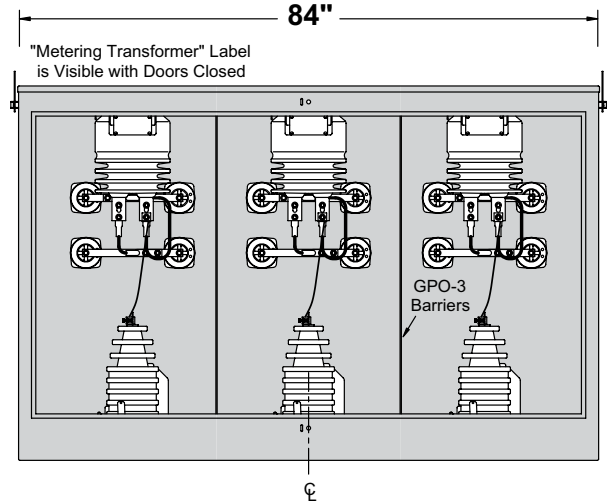

Rear View
Doors & Door Safety Barriers Removed

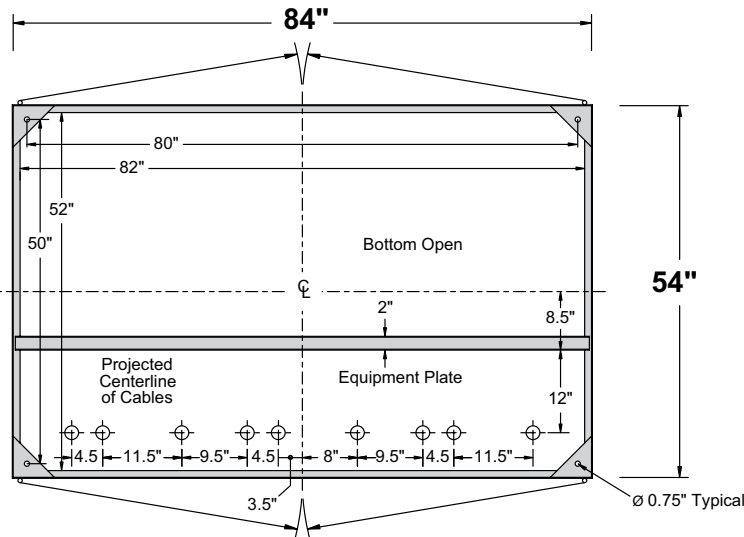

Section BB

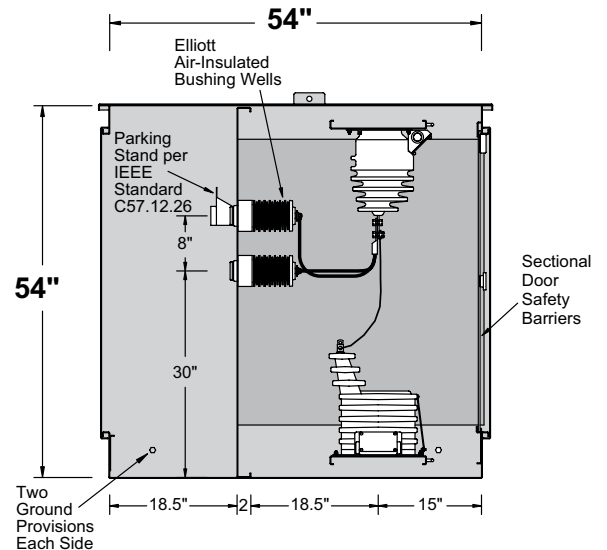

Section AA

① Bushing wells may be added if circuit requirements change - see page 13 in this bulletin.

EPM-PMS-25-321P-E2

NEMA Standard Outdoor Instrument Transformers



25-kV Safefront 200 Amp Primary Metering Station

Pad-Mounted – Outdoor

Bulletin
500-202
Page 8 2018

Cable Training and Anchor Bolt Locations

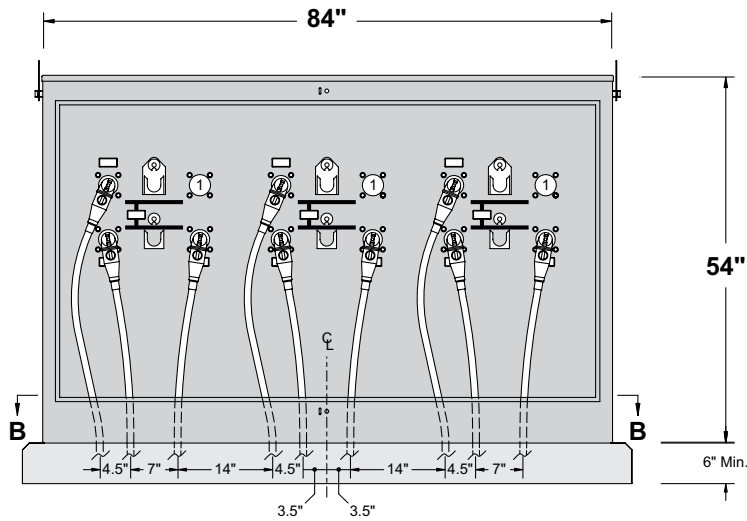

Front View
Doors Removed

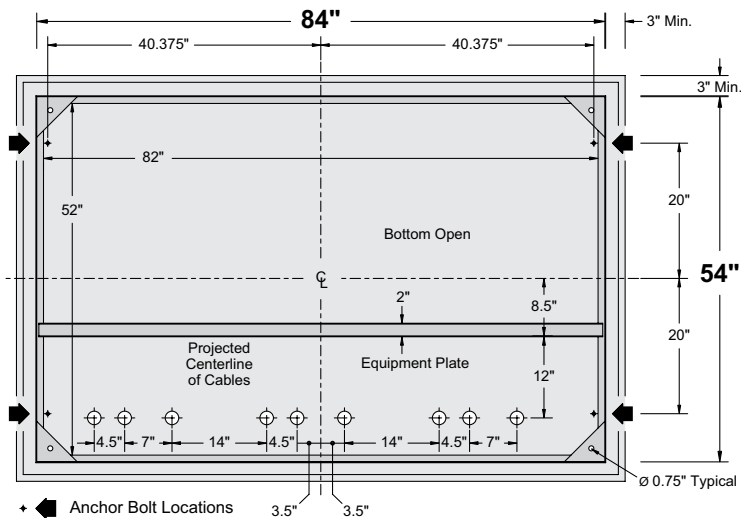
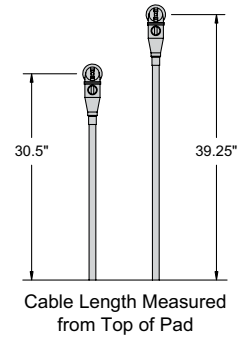

Section BB
and Typical Pad Dimensions

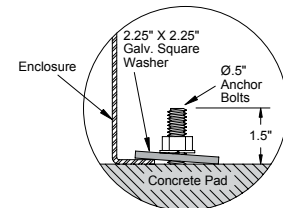

Alternate #1

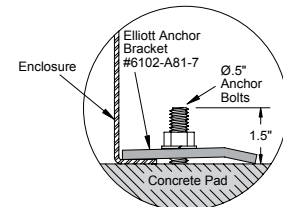

Alternate #2

① Bushing wells may be added if circuit requirements change - see page 13 in this bulletin.

EPM-PMS-25-312P-E2

NEMA Standard Outdoor
Instrument Transformers

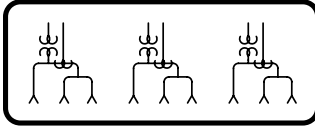

Three Phase – Three Ways per Phase
200 Amp Elliott Air-Insulated Bushing Wells
NEMA Standard Outdoor Instrument Transformers
15.2/26.3 kV Grounded Wye Max Design
60 Hertz, 125 kV BIL

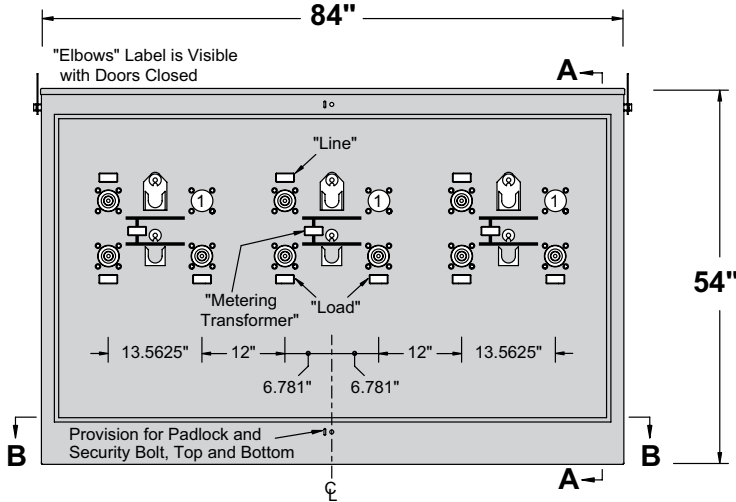

Front View
Doors Removed

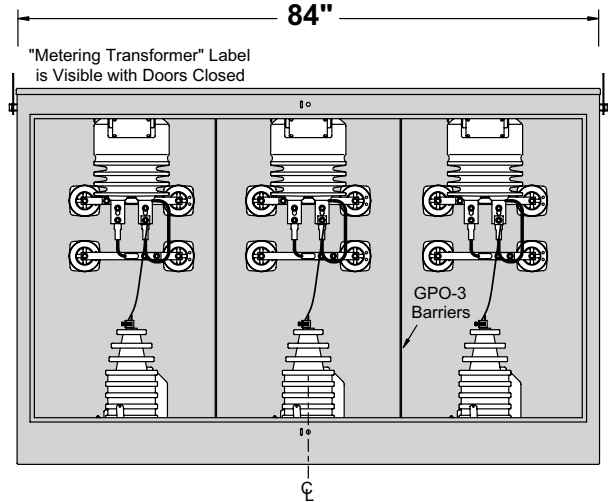

Rear View
Doors & Door Safety Barriers Removed

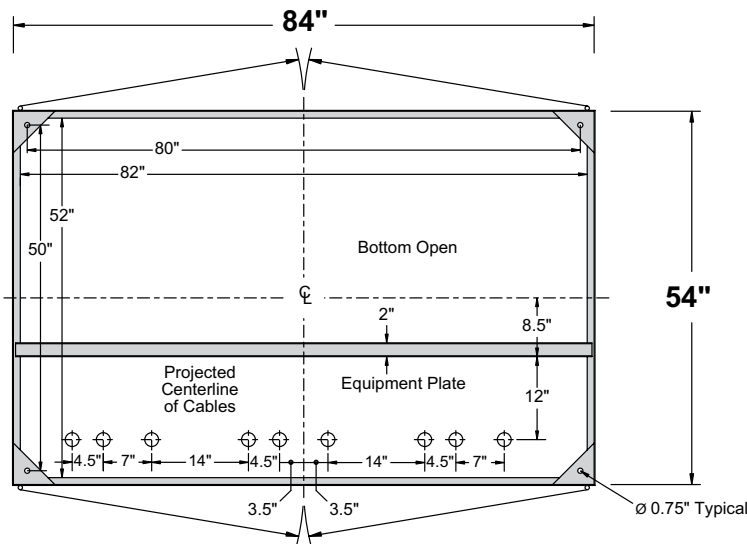

Section BB

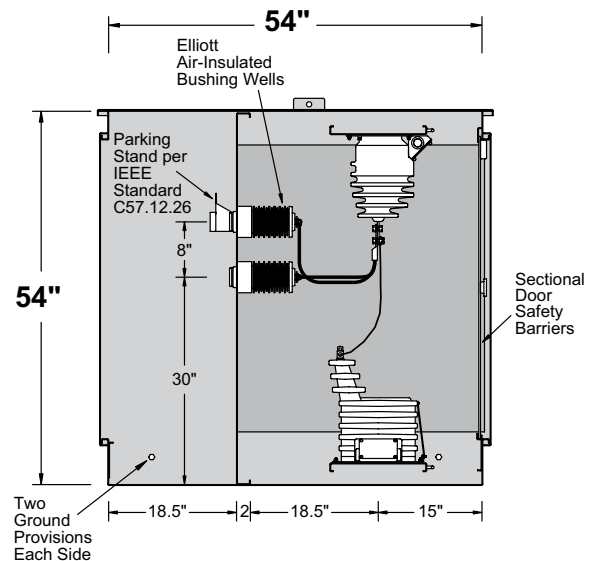

Section AA

① Bushing wells may be added if circuit requirements change - see page 13 in this bulletin.

EPM-PMS-25-312P-E2

NEMA Standard Outdoor Instrument Transformers



25-kV Safefront 200 Amp Primary Metering Station

Pad-Mounted – Outdoor

Bulletin
500-202
Page 10 2018

Cable Training and Anchor Bolt Locations

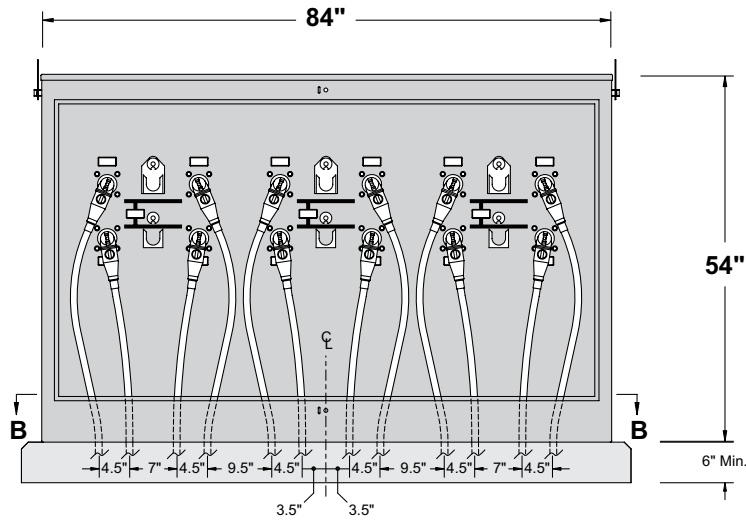

Front View
Doors Removed

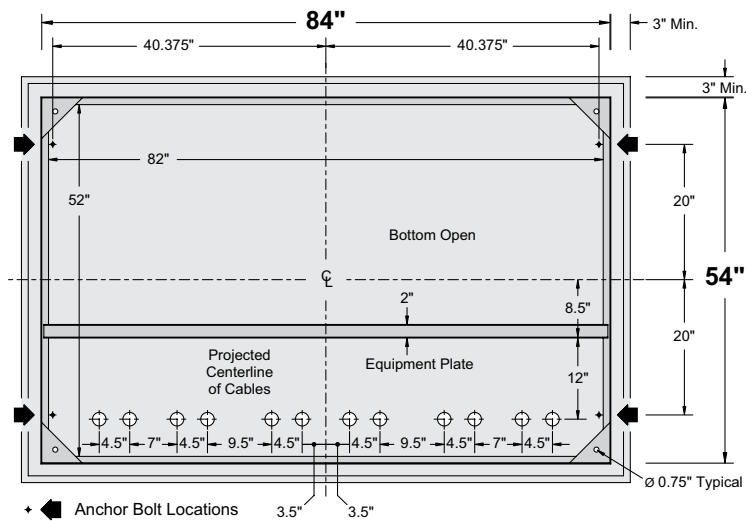
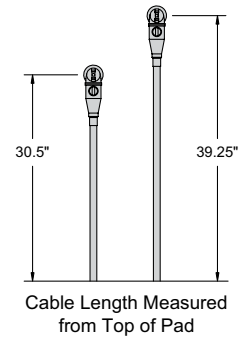

Section BB
and Typical Pad Dimensions

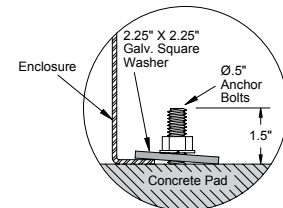

Alternate #1

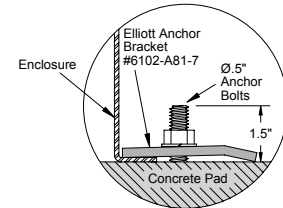

Alternate #2

EPM-PMS-25-322P-E2

NEMA Standard Outdoor
Instrument Transformers

Elastimold® is a registered trademark of ABB Asea Brown Boveri Ltd.

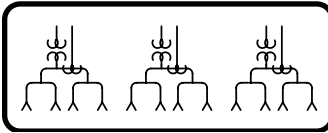

Three Phase – Four Ways per Phase
200 Amp Elliott Air-Insulated Bushing Wells
NEMA Standard Outdoor Instrument Transformers
15.2/26.3 kV Grounded Wye Max Design
60 Hertz, 125 kV BIL

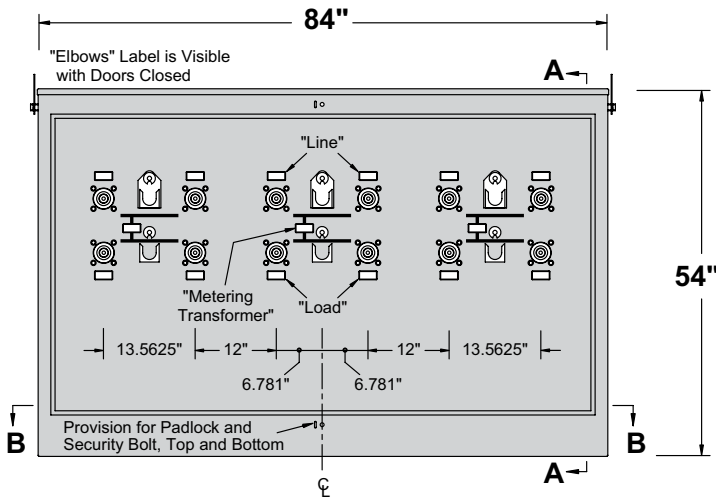

Front View
Doors Removed

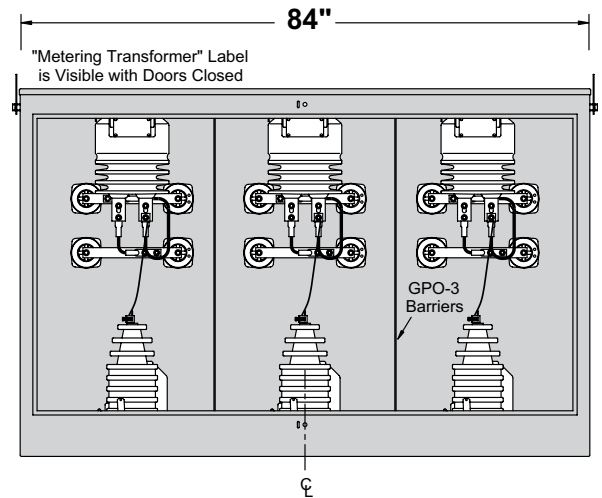

Rear View
Doors & Door Safety Barriers Removed

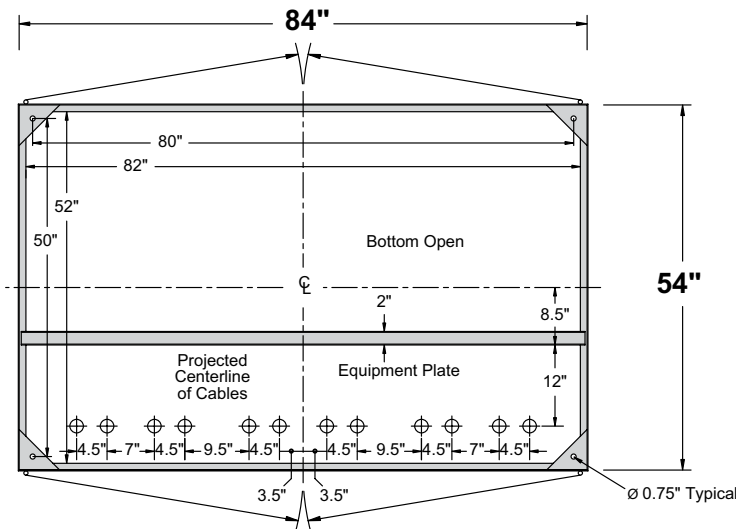

Section BB

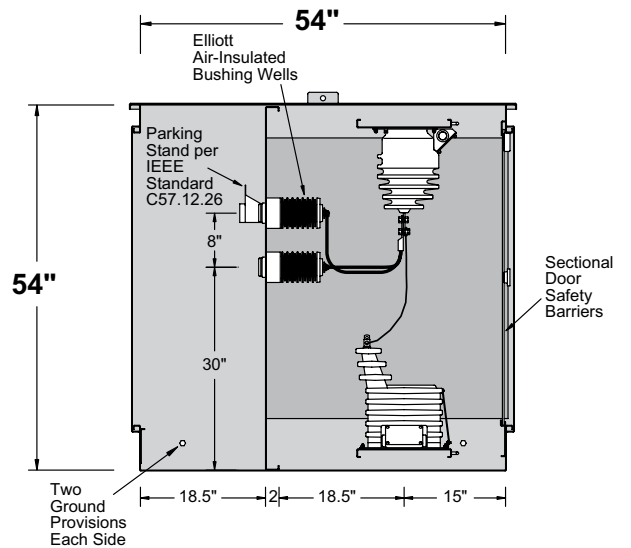

Section AA

EPM-PMS-25-322P-E2

NEMA Standard Outdoor Instrument Transformers

200 Amp Bushing Well #1101-225B

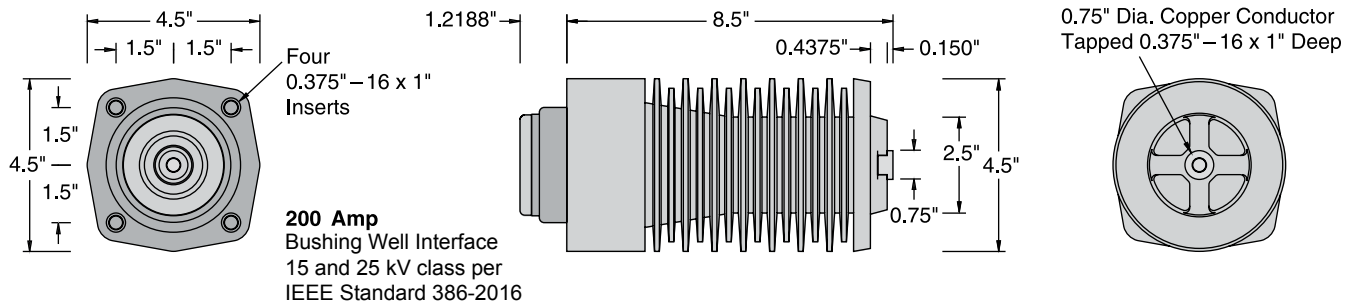

Voltage Class.....	25 kV	Leakage Distance, Inches	34
Phase-to-Ground Voltage	15.2 kV	Dry Arcing Distance, Inches.....	8.5
BIL	125 kV	Mechanical - Strength Rating, Pounds	
AC Withstand - 1 Min. Dry	40 kV	Cantilever, Ultimate 2.5 inches past end.....	>1,000
10 Sec. Dew	40 kV	Tensile, Pounds	>5,000
DC Withstand - 15 Min. Dry	78 kV	Torsion, Inch Pounds (bolt breaks).....	>700
Corona Extinction Level - Minimum.....	19 kV	Compression, Pounds	20,000
Continuous Current	200 Amps	Insert Thread Size	0.375"–16 x 1"
Momentary - RMS, Sym., 0.17 sec.....	10,000 Amps	Conductor (live end) Thread Size.....	0.375"–16 x 1"
RMS, Sym., 3 sec.....	3,500 Amps	Net Weight, Pounds (kg).....	6.75 (3.06)

Typical Specifications - 200 Amp 15 & 25-kV Bushing Wells

Bushings shall be 200 ampere Elliott #1101-225B, 25 kV class (15.2 kV to ground) Air-Insulated Bushing Wells, 125 kV BIL, per IEEE Standard 386-2016 Fig. 3 (Interface 3: a 200 A bushing well interface) for use with either 8.3/14.4 kV or 15.2/26.3 kV separable insulated connectors (Elastimold®, Eaton's Cooper Power Systems or other approved equal). The bushing wells shall be pressure-molded cycloaliphatic epoxy with a 0.75-inch diameter copper conductor on the "air-insulated" side that is drilled and tapped 0.375-inch – 16UNC x 1-inch deep to provide direct connection of the bus and/or live parts. Leakage distance from the apparatus connection end of the bushing well to ground shall be not less than 30 inches to assure trouble-free operation in a wet and/or contaminated environment. Integral shielding shall be provided to eliminate partial discharge caused by off-center mounting and mounting holes that may have sharp edges or burrs. Bushing wells shall mount in a 3.125-inch diameter opening and bolt in place to allow field replacement with standard tools. The bushing well mounting bolts shall be self-locking stainless steel serrated-flange hex-head bolts that "cut" through the enclosure protective finish to ground

the integral shielding of each bushing well. The head of one or more of the mounting bolts for each bushing well shall include a 0.156-inch diameter hole to provide a connection to ground for the loadbreak insert shielding ground wire as recommended by separable insulated connector manufacturers. To assure adequate strength for apparatus support, the bushing well shall withstand a minimum cantilever loading of 600 pounds for five minutes without damage. The bushing well interface shall be free of all voids, holes and heat sinks to assure proper mating with separable insulated connectors. Each bushing well shall be tested in free air, mounted in a grounded steel plate not less than 10 inches x 10 inches, with a bushing well plug (Eaton's Cooper Power Systems #IBWP225 or equal) installed in the well interface to accurately simulate operating conditions (*gas or liquid dielectric in the interface shall not be acceptable for this test*). Each bushing well shall meet the requirements for 25 kV devices in accordance with IEEE Standard 386 (latest revision), including 100 percent production testing.

Elastimold® is a registered trademark of ABB Asea Brown Boveri Ltd.

Bushing Well Installation Instructions

The primary metering stations shown in this bulletin have equipment plates punched to accept twelve bushing wells. When you purchase a primary metering station requiring less than twelve bushings, the extra mounting holes are closed with “bushing-style” insulators or adapter plates. If circuit requirements change, bushing wells can be added or removed to provide the circuit arrangements shown in this bulletin. The mounting hardware used to

mount the “bushing-style” insulator or adapter plate is the same hardware used to install a bushing well. There is no need to drill holes when modification is required.

NOTE: *The primary metering station must be de-energized and grounded in accordance with your company’s normal safety procedure before any modifications are made.*

Procedure for Bushing Well Installation

NOTE: *The shipping cap on the bushing well should be left in place to prevent contamination of the interface.*

1. Remove the bolt which fastens the bus bar to the “bushing-style” insulator.
2. On the opposite end of the bus bar, loosen the bolt which fastens the bus bar to the bushing. The bus bar will then drop down so the “bushing-style” insulator or adapter plate assembly can be easily removed.
3. Remove the “bushing-style” insulator or adapter plate from the equipment plate (retain for future use).
4. Install the bushing well into the mounting hole from the metering transformer side.
5. Install the serrated-flange bolts. Bolts should be tightened in a uniform manner applying no more than 90 inch-pounds torque to each bolt. The serrated-flange bolts must “cut” into the mounting plate to

provide a connection from the shielding to the grounded equipment mounting plate.

6. Connect the copper bus bar to the bushing well just installed using hardware previously removed.
7. Tighten the bolt on both ends of the bus bar no more than 216 inch-pounds.

IMPORTANT: *Do not energize this bushing well with only the shipping cap in place.* To do so would lead to failure of the bushing well and create a hazard to operating personnel. *This product is designed to be used only when it is mated with an appropriate 25 kV class bushing insert and elbow conforming to the latest revision of IEEE Standard 386.* The bushing insert and elbow should be installed in accordance with the instructions supplied by the connector manufacturer.

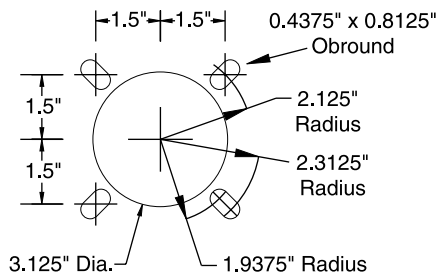

Uni-Mount Mounting Holes

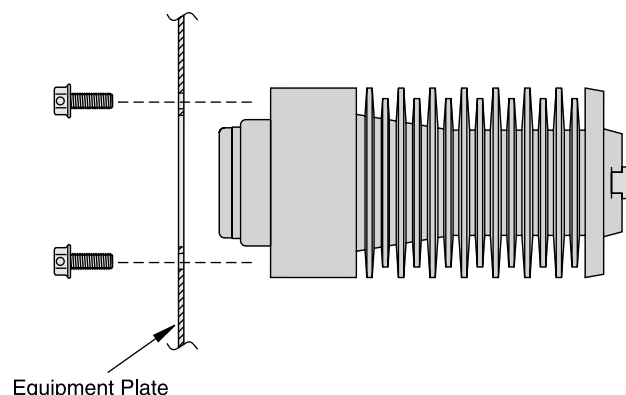

Typical Specification - Page 1 of 2**General**

The primary metering station shall be 25 kV class, 125 kV BIL, 200 ampere continuous current, suitable for use on 15.2/26.3 kV grounded wye max design systems. The primary metering station shall be constructed for connection to the utility system with loadbreak separable insulated connectors as described in IEEE Standard 386—latest revision (separable insulated connectors and loadbreak inserts shall be supplied by the user). The metering station shall be designed for and contain (or accept) standard outdoor instrument transformers in a compartment separated from the elbow compartment by a steel equipment plate. Separate access shall be provided for each compartment. A door safety barrier shall be provided inside the door(s) on the instrument transformer compartment as recommended in IEEE Standard C2 (National Electrical Safety Code) Rule 381G. Tamper resistance shall meet the Enclosure Security requirements of IEEE Standard C57.12.28 (Pad-Mounted Equipment—Enclosure Integrity). Together, the tamper resistance and the door safety barrier shall resist unauthorized entry, protect authorized and unauthorized persons, and provide positive safety features when installed in areas accessible to the general public. The primary metering station shall be constructed for outdoor installation in areas subject to heavy precipitation and in areas with windblown contamination. The equipment shall be “air-insulated” and completely assembled prior to shipment.

Enclosure Construction

The enclosure shall be tamper-resistant, all-welded construction utilizing 11-gauge minimum sheet steel. Corner plates and braces shall be used as necessary to assure rigidity. The enclosure top shall be cross-kinked to provide watershed and rigidity. The enclosure shall be open bottom with a 1-inch flange inside, all around. Separate compartments shall be provided for cable termination and for instrument transformers—each compartment equipped with its own individual access door(s) furnished with a stainless steel door holder that will latch the door open 100 degrees and 140 degrees and resist accidental closing. The equipment plate separating the two compartments shall be full length, constructed with 11-gauge minimum sheet steel braced to assure rigidity when operating the elbows. Doors shall be provided with provisions for padlocking and a recessed penta-head (or hex-head) security bolt to prevent unauthorized entry (coordinated to prevent installation of the padlock until the security bolt is tightened *when closing the door(s)* and to prevent a wrench from operating the security bolt until the padlock is removed *when opening the door(s)*). The security bolt shall be made captive with a stainless steel washer compressed to an oval shape to severely discourage removal. Hinges shall be stainless steel (with stainless steel pins not less than 0.3125-inch diameter) and shall be welded to both the enclosure and the door to maintain door alignment for the life of the equipment. Instrument transformer mounting plates shall be constructed with 11-gauge minimum sheet steel formed and reinforced to provide proper support for instrument transformers installed (or to be installed) thereon. The mounting plates shall be punched with a pattern of holes that accept installation of all NEMA Standard

outdoor instrument transformers without the need to punch or drill additional holes. The pattern of holes shall be located to place the instrument transformers in a position that provides proper electrical clearance. A 0.375-inch diameter cable-lacing rod shall be welded to the front edge of each transformer mounting plate and to both inside walls of the instrument transformer compartment (with stand-off clearance of 0.75-inch) to provide support for secondary wiring to be user (or factory) installed. The enclosure shall be nonventilated to minimize the entrance of airborne contamination, insects, rodents or reptiles. The protective finish shall include necessary grinding, cleaning and phosphatizing, two-component rust-inhibiting epoxy primer and a Pad-Mount Green two-component polyurethane top coat finish (Munsell color 7GY 3.29/1.5). The primer and top coat shall be electronically monitored during application to insure proper ratio and mixing of each component. Total average thickness of paint (after curing) shall be not less than 5 mils. The protective coating shall meet the Enclosure Coating System requirements of IEEE Standard C57.12.28 (Pad-Mounted Equipment—Enclosure Integrity). Removable lift provisions, adequate to withstand handling with normal utility equipment, shall be provided on the outside of the enclosure. Threaded openings for lift provision bolts shall be blind holes to prevent the entrance of wire or other foreign objects into the enclosure when lift provisions are removed.

Bushings and Terminals

Bushings shall be 200 ampere Elliott #1101-225B, 25 kV class (15.2 kV to ground) Air-Insulated Bushing Wells, 125 kV BIL, per IEEE Standard 386-2016 Fig. 3 (Interface 3: a 200 A Bushing Well Interface) *for use with either 8.3/14.4 kV or 15.2/26.3 kV separable insulated connectors* (Elastimold®, Eaton's Cooper Power Systems or other approved equal). The bushing wells shall be pressure-molded cycloaliphatic epoxy with a 0.75-inch diameter copper conductor on the “air-insulated” side that is drilled and tapped 0.375-inch – 16UNC x 1-inch deep to provide direct connection of the bus and/or live parts. Leakage distance from the apparatus connection end of the bushing well to ground shall be not less than 30 inches to assure trouble-free operation in a wet and/or contaminated environment. Integral shielding shall be provided to eliminate partial discharge caused by off-center mounting and mounting holes that may have sharp edges or burrs. Bushing wells shall mount in a 3.125-inch diameter opening and bolt in place to allow field replacement with standard tools. The bushing well mounting bolts shall be self-locking stainless steel serrated-flange hex-head bolts that “cut” through the enclosure protective finish to ground the integral shielding of each bushing well. The head of one or more of the mounting bolts for each bushing well shall include a 0.156-inch diameter hole to provide a connection to ground for the loadbreak insert shielding ground wire as recommended by separable insulated connector manufacturers. To assure adequate strength for apparatus support, the bushing well shall withstand a minimum cantilever loading of 600 pounds for five minutes without damage. The bushing well interface shall be free of all voids, holes and heat sinks to assure proper mating

Typical Specification - Page 2 of 2

with separable insulated connectors. Each bushing well shall be tested in free air, mounted in a grounded steel plate not less than 10 inches x 10 inches, with a bushing well plug (Eaton's Cooper Power Systems #IBWP225 or equal) installed in the well interface to accurately simulate operating conditions (*gas or liquid dielectric in the interface shall not be acceptable for this test*). Each bushing well shall meet the requirements for 25 kV devices in accordance with IEEE Standard 386 (latest revision), including 100 percent production testing.

Instrument Transformers

Alternate 1: Instrument transformers and primary wiring shall be supplied and installed by the user.

Alternate 2: Instrument transformers shall be supplied and installed by the user. Dummy current transformers shall be provided to support factory-installed copper primary wiring suitable to connect the CTs and VTs installed by the user.

Alternate 3: Instrument transformers shall be metering accuracy, installed complete with copper primary wiring and #6 solid-copper ground conductors. CT ratio, VT ratio and acceptable brands shall be specified by the user.

Alternate 4: Instrument transformers shall be relay accuracy, installed complete with copper primary wiring and #6 solid-copper ground conductors. CT ratio, VT ratio and acceptable brands shall be specified by the user.

Secondary Wiring

Alternate 1: Secondary wiring shall be supplied and installed by the user.

Alternate 2: Secondary wiring shall be #10 THW/XHHW stranded-copper wire connecting the instrument transformer secondary to the 10-Terminal Test Switch and 13-Terminal Meter Socket installed on the right-hand exterior wall of the primary metering station (when facing the elbow compartment). The secondary wiring shall be color-coded as specified by the user (or the factory color code when the user does not specify a color code).

Alternate 3: Secondary wiring shall be #10 THW/XHHW stranded-copper wire connecting the instrument transformer secondary to a four-terminal block for the VTs and a six-terminal shorting block for the CTs. The terminal blocks shall be located in the instrument transformer compartment near the ground lug on the left inside wall (when facing the instrument transformer compartment). The secondary wiring shall be color-coded as specified by the user (or the factory color code when the user does not specify a color code).

Surge Arresters

Alternate 1: Mounting provisions for distribution-class metal-oxide-varistor surge arresters shall be provided in the instrument transformer compartment, located so the arresters can be installed and replaced without disturbing other components in the transformer compartment.

Alternate 2: Three 18-kV heavy-duty distribution-class metal-oxide-varistor surge arresters, with silicone-rubber housings and ground-lead isolators, shall be provided in the instrument transformer compartment, located so the arresters

can be replaced without disturbing other components in the transformer compartment. One arrester terminal shall be connected to the source bushing. The ground-lead isolator shall be connected in a manner that will guide the isolator clear of other components in the event of an isolator operation.

Barriers

Phase and ground barriers shall be provided to assure correct phase-to-phase and phase-to-ground clearances for proper operation at rated voltage. These barriers shall be glass-reinforced polyester (NEMA GPO-3 class material) not less than 0.1875-inch thick.

For each phase, a removable insulating barrier with a "DANGER – Keep Out! – Hazardous voltage" sign, Elliott #7203-D2003-309, shall be located inside the door(s) on the transformer compartment as recommended in Rule 381G of IEEE Standard C2 (National Electrical Safety Code). These *sectional door safety barriers* shall be constructed of 0.25-inch clear polycarbonate (Lexan or equal) and *shall completely close the opening* to each phase. Each barrier shall be provided with a nonconductive safety latch requiring a positive action to remove the barrier. Handles and other hardware extending through the door safety barriers shall be nonconductive material. Handles shall be keyed to prevent rotation for secure handling. *Complete visual inspection of the internal components shall be possible without removing the door safety barrier.*

Grounding Provisions

Four high-conductivity bronze eyebolt-type ground lugs, which accept #6 through #2/0 copper conductor, shall be installed—two in the cable terminating compartment and two in the transformer compartment—on each side of the door opening in an accessible position (as shown on the drawings).

Accessory Equipment

Stainless steel parking stands shall be provided in the quantity required to allow use of feed-thru bushings, parking bushings and grounding bushings. The parking stands between the upper bushings shall extend 3 inches from the equipment plate per IEEE Standard C57.12.26 for improved switching operations. The parking stands shall be welded in place, in a position to allow the use of hot-line tools for installation of feed-thru bushings, etc. The parking stands shall be *unpainted* (except welds shall be painted) *to provide a ground* for feed-thru bushings and other devices that may be placed into the parking stands. *Keyed retainers* shall be welded above each parking stand to *prevent slipping or accidental removal* of portable devices such as feed-thru bushings, etc.

A corrosion proof nameplate with permanent thermal transfer printing shall be installed inside one door on the elbow compartment. It shall be located at the top corner farthest from the elbows when the door is open. The nameplate will provide Type of Equipment, Model Number, Amps Continuous, kV Maximum, BIL, Serial Number, Job Number, Date Manufactured and Weight of Equipment.

Bus and instrument transformer connections between bushings shall be displayed (on the cable side of the equipment



25-kV Safefront 200 Amp Primary Metering Station

Pad-Mounted – Outdoor

Bulletin
500-202
Page 16 2018

Typical Specification - Page 3 of 3

plate) using 0.5-inch-wide solid orange-color pressure-sensitive vinyl tape. Bushings shall be labeled as "LINE" or "LOAD" with vinyl labels using letters not less than 0.375-inch nor more than 0.625-inch high. The resulting schematic shall clearly indicate the circuit arrangement of the metering station. The schematic shall be legible at a distance of six feet or more.

When enclosures have more than one door (or other access provision) each access shall be labeled in near proximity of the locking provisions with a pressure-sensitive vinyl label using letters not less than 0.375-inch nor more than 0.625-inch high. The label shall indicate the type of equipment behind the access (elbows, transformers, etc.).

When specified, four anchor-bolt brackets, Elliott #6102-A81-7 or approved equal, shall be supplied with each metering station to provide a means of clamping the equipment to the concrete pad.

Packaging

Each metering station shall be bolted to a solid-top wood pallet (to prevent the forks of a forklift truck from entering the open bottom of the equipment) to prevent hidden damage. The equipment shall be wrapped with 0.125-inch thick polyethylene foam or other suitable material to minimize damage to the finish during shipment.

Drawings

When specified, drawings shall be furnished for each metering station that include:

- 1) enclosure dimensions and location of components.
- 2) proposed cable-training layout and dimensions.
- 3) proposed pad dimensions and location of anchor bolts.

Information needed to provide a Primary Metering Station Quotation

Actual System Voltage (Example: 7.2/12.47 kV Grd. Wye): _____

Line Bushings per Phase: 1 2

Load Bushings per Phase: 1 2

Enclosure: Standard 11-gauge Steel 0.125" Aluminum 12-gauge Stainless Steel

Primary Wiring Installed: Yes No

CTs, VTs Installed: Yes No CT Ratio _____ :5 VT Ratio _____ :1

Preferred Brand of Transformers: ABB GE Either Other _____

Secondary Wiring Installed (only when CTs and VTs are supplied): Yes No

Secondary Wiring Connected to: Test Switch & Meter Socket Terminal Blocks

Special Secondary Wiring Color Code: Yes No

Surge Arresters Installed: Yes No

Your Name, Company Name, Complete Postal Address and E-mail Address:

Name and Complete Shipping Address:

Project Name:

NOTE: Single phase and two phase Primary Metering Stations are available. Contact our representative or the factory.

Elastimold® is a registered trademark of ABB Asea Brown Boveri Ltd.