

25-kV Wall-Mount Fuse-Gear

200 Amp S&C SMU-20 and SM-4 Fuses

Three Phase – Indoor/Outdoor

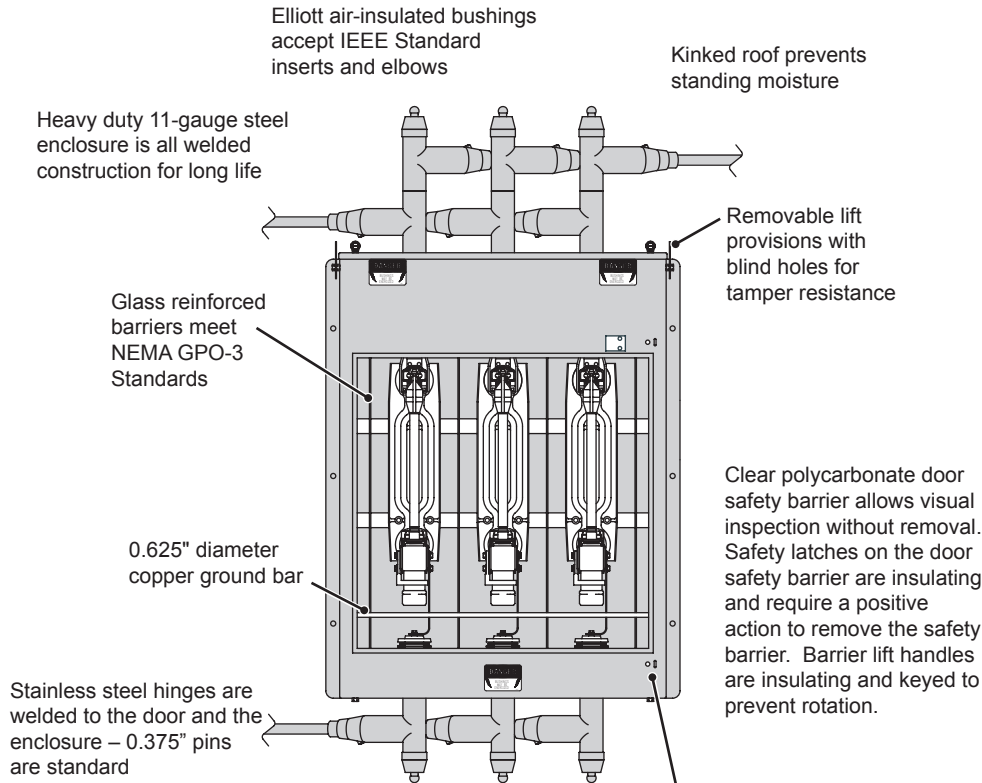

Tamper-Resistant Enclosure meets National and Regional Enclosure Integrity Standards and virtually eliminates the entrance of airborne contamination to reduce maintenance

Superlife Finish Includes phosphatizing, rust-inhibiting epoxy primer and Pad-Mount Green (Munsell 7GY 3.29/1.5) polyurethane top coat - over 5 mils dry
Optional Paint: Grey (Munsell 5BG 7.0/0.4)

Corrosion proof nameplate is located to provide easy access for the operator

Coordinated padlock and penta-head or optional hex-head bolt (top and bottom) provides bolted-door security with visual confirmation by supervisory personnel. Security bolt is made captive with a stainless steel washer compressed to an oval shape to severely discourage removal.

Overlapping door and enclosure flanges - with other features - provide tamper resistance to meet national and regional standards

Door-holder rods are stainless steel and hold the door open 100 degrees or 140 degrees

"In-Air" Insulation eliminates leaking or contamination of insulating medium for long trouble-free operation

"In-Air" Visibility allows visual inspection of all components without the inconvenience or expense associated with equipment which must be de-energized for inspection

Parking stands are unpainted stainless steel and provide space and grounding for feed-thru and other portable devices

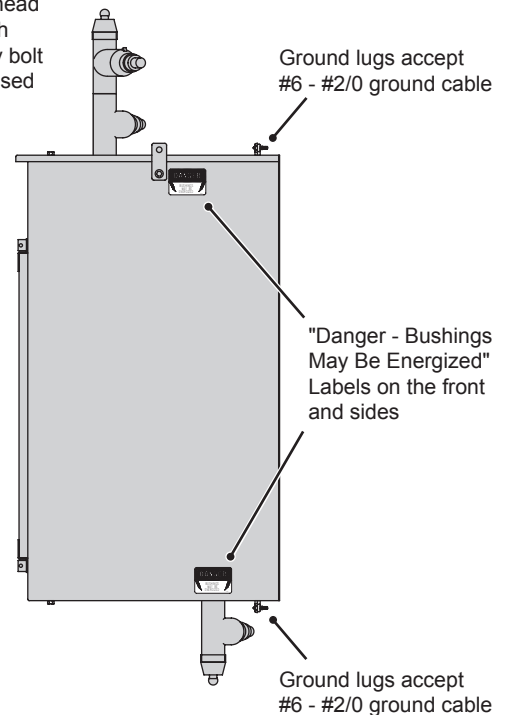

ENCLOSURE OPTIONS:

- 1) 0.125" #5052H32 Aluminum
- 2) 12-gauge #304L Stainless Steel



Three-Phase – Two Ways Per Phase

200 Amp Elliott Air-Insulated Bushing Wells
 15.2/26.3 kV Grounded Wye Max Design
 125 kV BIL

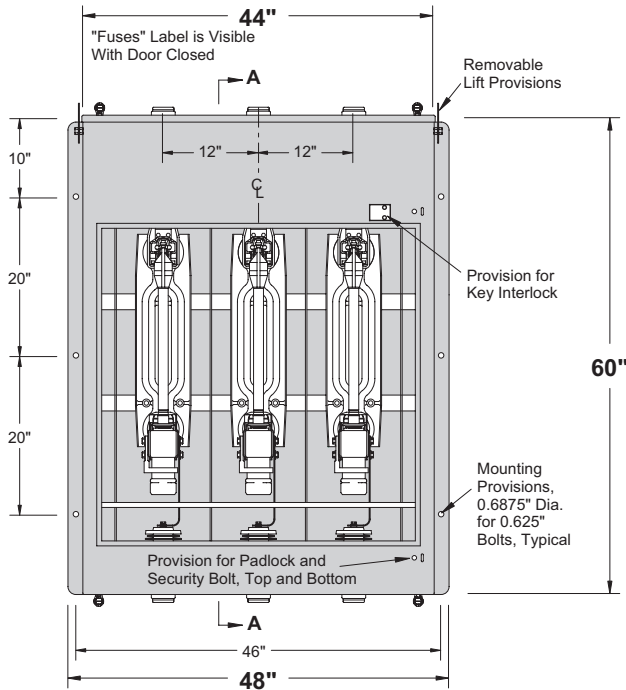

Front View

Door & Door Safety Barrier Removed

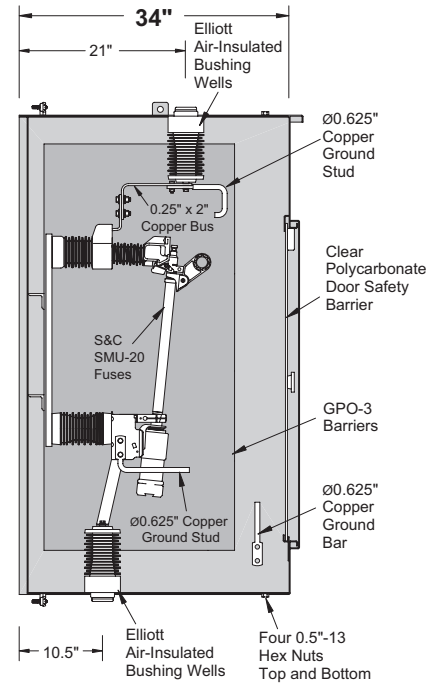

Section AA

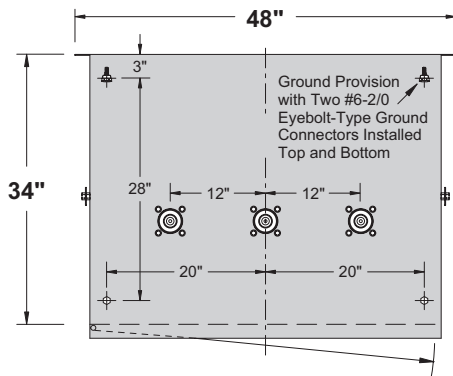

Top View

- 11-Gauge Steel Enclosure
- Stainless Steel Hinges
- Provisions for Padlock and recessed Stainless Steel Penta-Head (or Hex-Head) Security Bolts
- Clear Polycarbonate Door Safety Barrier Standard
- 8" Min. Strike Distance to Ground
- 10" Min. Strike Distance Phase-to-Phase

- Standard Paint: "Pad-Mount Green" (Munsell #7GY 3.29/1.5)
- Optional Paint: "Light Grey" (Munsell #5BG 7.0/0.4)
- Option G1: Ground studs at main contact of fuse mounting
- Option G2: Ground studs at hinge end of fuse mounting
- Option K: Key interlock

Catalog Number	Fuse Mounting	Fuse End Fittings/Holder	Fuse Unit/Refill
EWMR-25-311S-E2TB-SM20	SM-20 without Uni-Rupter®	SM-20 / SML-20 Cat. #3097	SMU-20 200K or 200E Max
EWMR-25-311S-E2TB-SML20	SML-20 with Uni-Rupter®	SM-20 / SML-20 Cat. #3097	SMU-20 200K or 200E Max
EWMR-25-311S-E2TB-SMX4	SMX-4 without Uni-Rupter®	SML-4Z Cat. #92353	SM-4 200E Max
EWMR-25-311S-E2TB-SML4	SML-4Z with Uni-Rupter®	SML-4Z Cat. #92353	SM-4 200E Max

Uni-Rupter® is a registered trademark of S&C Electric Company.

NX® and X-Limiter™ are either registered trademarks or trademarks of Eaton in the U.S. and other countries.

Elastimold® is a registered trademark of ABB Asea Brown Boveri Ltd.



Three-Phase – Two Ways Per Phase

200 Amp Elliott Air-Insulated Bushing Wells
 15.2/26.3 kV Grounded Wye Max Design
 125 kV BIL

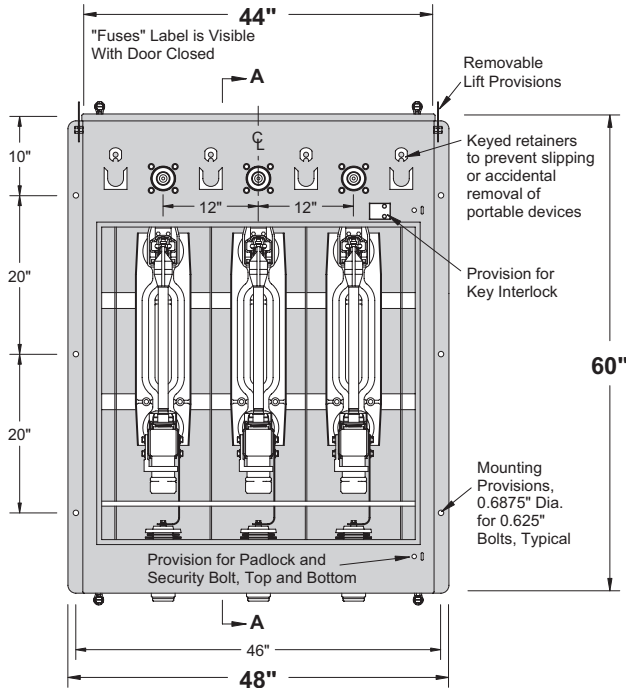

Front View

Door & Door Safety Barrier Removed

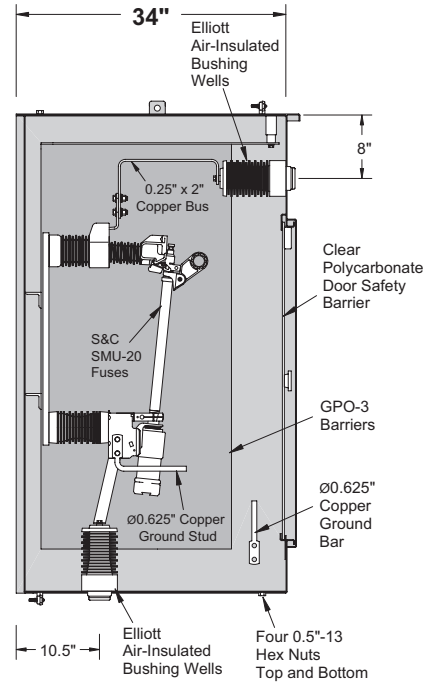

Section AA

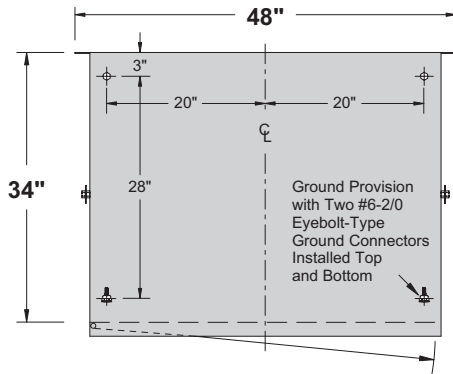

Top View

- 11-Gauge Steel Enclosure
- Stainless Steel Hinges
- Provisions for Padlock and recessed Stainless Steel Penta-Head (or Hex-Head) Security Bolts
- Clear Polycarbonate Door Safety Barrier Standard
- 8" Min. Strike Distance to Ground
- 10" Min. Strike Distance Phase-to-Phase

Standard Paint: "Pad-Mount Green" (Munsell #7GY 3.29/1.5)
 Optional Paint: " Light Grey" (Munsell #5BG 7.0/0.4)
 Option G2: Ground studs at hinge end of fuse mounting
 Option K: Key interlock

Catalog Number	Fuse Mounting	Fuse End Fittings/Holder	Fuse Unit/Refill
EWMR-25-311S-E2FB-SM20	SM-20 without Uni-Rupter®	SM-20 / SML-20 Cat. #3097	SMU-20 200K or 200E Max
EWMR-25-311S-E2FB-SML20	SML-20 with Uni-Rupter®	SM-20 / SML-20 Cat. #3097	SMU-20 200K or 200E Max
EWMR-25-311S-E2FB-SMX4	SMX-4 without Uni-Rupter®	SML-4Z Cat. #92353	SM-4 200E Max
EWMR-25-311S-E2FB-SML4	SML-4Z with Uni-Rupter®	SML-4Z Cat. #92353	SM-4 200E Max

Uni-Rupter® is a registered trademark of S&C Electric Company.

NX® and X-Limiter™ are either registered trademarks or trademarks of Eaton in the U.S. and other countries.

Elastimold® is a registered trademark of ABB Asea Brown Boveri Ltd.

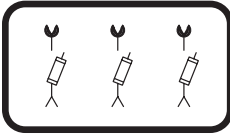

Three-Phase – Two Ways Per Phase
 600 Amp Elliott Air-Insulated Bushings
 200 Amp Elliott Air-Insulated Bushing Wells
 15.2/26.3 kV Grounded Wye Max Design
 125 kV BIL

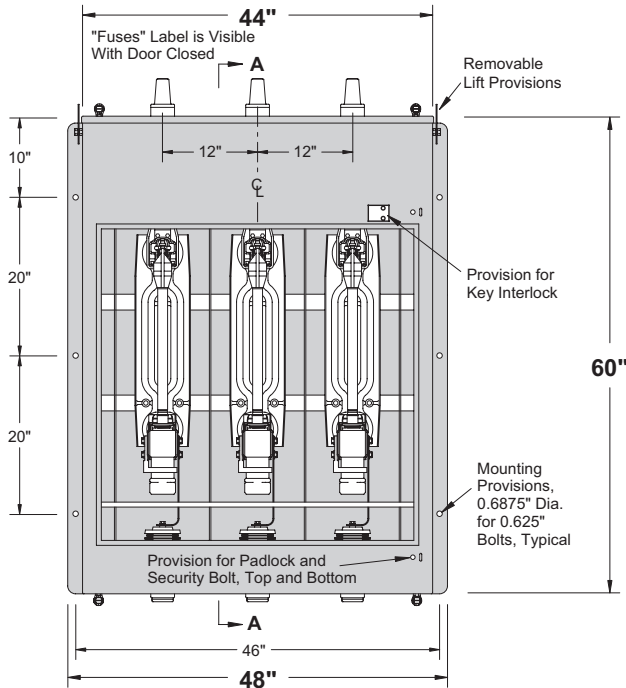

Front View

Door & Door Safety Barrier Removed

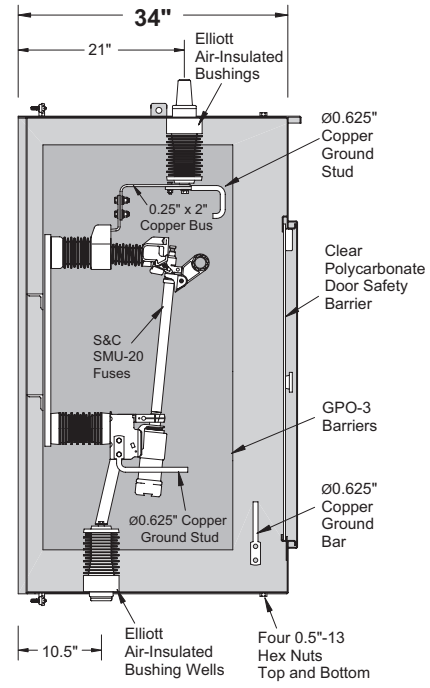

Section AA

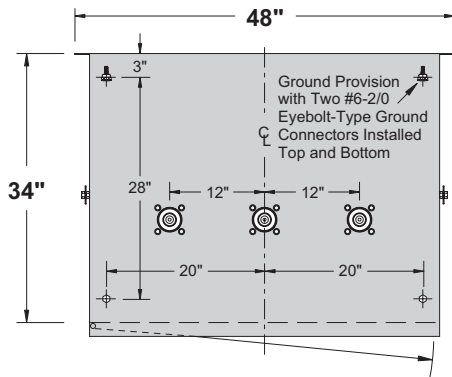

Top View

- 11-Gauge Steel Enclosure
- Stainless Steel Hinges
- Provisions for Padlock and recessed Stainless Steel Penta-Head (or Hex-Head) Security Bolts
- Clear Polycarbonate Door Safety Barrier Standard
- 8" Min. Strike Distance to Ground
- 10" Min. Strike Distance Phase-to-Phase

- Standard Paint: "Pad-Mount Green" (Munsell #7GY 3.29/1.5)
- Optional Paint: "Light Grey" (Munsell #5BG 7.0/0.4)
- Option G1: Ground studs at main contact of fuse mounting
- Option G2: Ground studs at hinge end of fuse mounting
- Option K: Key interlock

Catalog Number	Fuse Mounting	Fuse End Fittings/Holder	Fuse Unit/Refill
EWMR-25-311S-E6T/E2B-SM20	SM-20 without Uni-Rupter®	SM-20 / SML-20 Cat. #3097	SMU-20 200K or 200E Max
EWMR-25-311S-E6T/E2B-SML20	SML-20 with Uni-Rupter®	SM-20 / SML-20 Cat. #3097	SMU-20 200K or 200E Max
EWMR-25-311S-E6T/E2B-SMX4	SMX-4 without Uni-Rupter®	SML-4Z Cat. #92353	SM-4 200E Max
EWMR-25-311S-E6T/E2B-SML4	SML-4Z with Uni-Rupter®	SML-4Z Cat. #92353	SM-4 200E Max

Uni-Rupter® is a registered trademark of S&C Electric Company.

NX® and X-Limiter™ are either registered trademarks or trademarks of Eaton in the U.S. and other countries.

Elastimold® is a registered trademark of ABB Asea Brown Boveri Ltd.

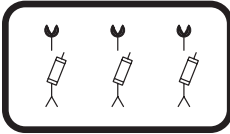

Three-Phase – Two Ways Per Phase
 600 Amp Elliott Air-Insulated Bushings
 200 Amp Elliott Air-Insulated Bushing Wells
 15.2/26.3 kV Grounded Wye Max Design
 125 kV BIL

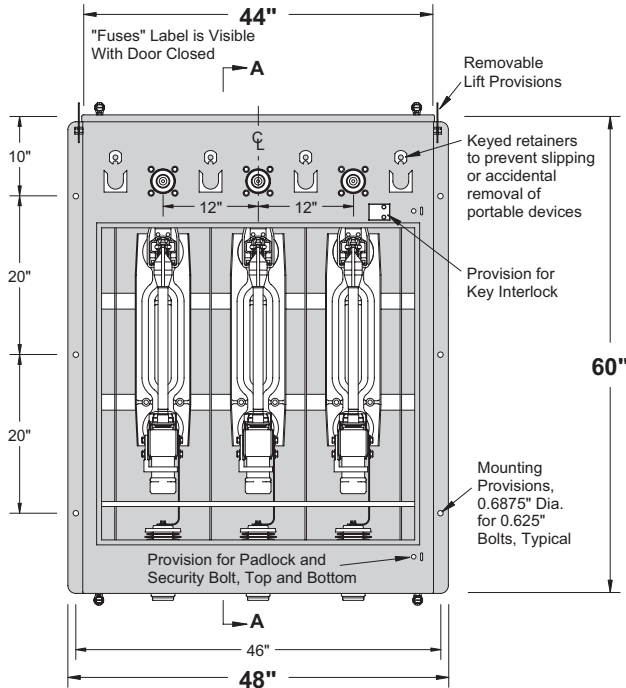

Front View

Door & Door Safety Barrier Removed

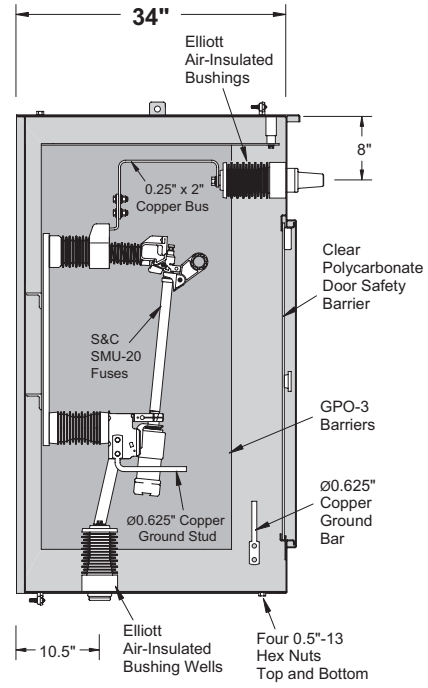

Section AA

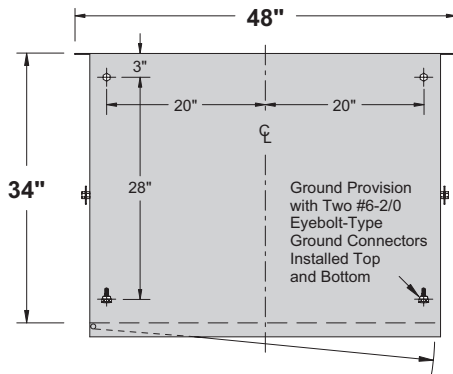

Top View

- 11-Gauge Steel Enclosure
- Stainless Steel Hinges
- Provisions for Padlock and recessed Stainless Steel Penta-Head (or Hex-Head) Security Bolts
- Clear Polycarbonate Door Safety Barrier Standard
- 8" Min. Strike Distance to Ground
- 10" Min. Strike Distance Phase-to-Phase

- Standard Paint: "Pad-Mount Green" (Munsell #7GY 3.29/1.5)
- Optional Paint: "Light Grey" (Munsell #5BG 7.0/0.4)
- Option G2: Ground studs at hinge end of fuse mounting
- Option K: Key interlock

Catalog Number	Fuse Mounting	Fuse End Fittings/Holder	Fuse Unit/Refill
EWMR-25-311S-E6F/E2B-SM20	SM-20 without Uni-Rupter®	SM-20 / SML-20 Cat. #3097	SMU-20 200K or 200E Max
EWMR-25-311S-E6F/E2B-SML20	SML-20 with Uni-Rupter®	SM-20 / SML-20 Cat. #3097	SMU-20 200K or 200E Max
EWMR-25-311S-E6F/E2B-SMX4	SMX-4 without Uni-Rupter®	SML-4Z Cat. #92353	SM-4 200E Max
EWMR-25-311S-E6F/E2B-SML4	SML-4Z with Uni-Rupter®	SML-4Z Cat. #92353	SM-4 200E Max

Uni-Rupter® is a registered trademark of S&C Electric Company.

NX® and X-Limiter™ are either registered trademarks or trademarks of Eaton in the U.S. and other countries.

Elastimold® is a registered trademark of ABB Asea Brown Boveri Ltd.

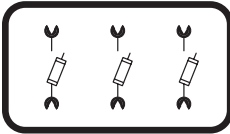

Three-Phase – Two Ways Per Phase

600 Amp Elliott Air-Insulated Bushings
15.2/26.3 kV Grounded Wye Max Design
125 kV BIL

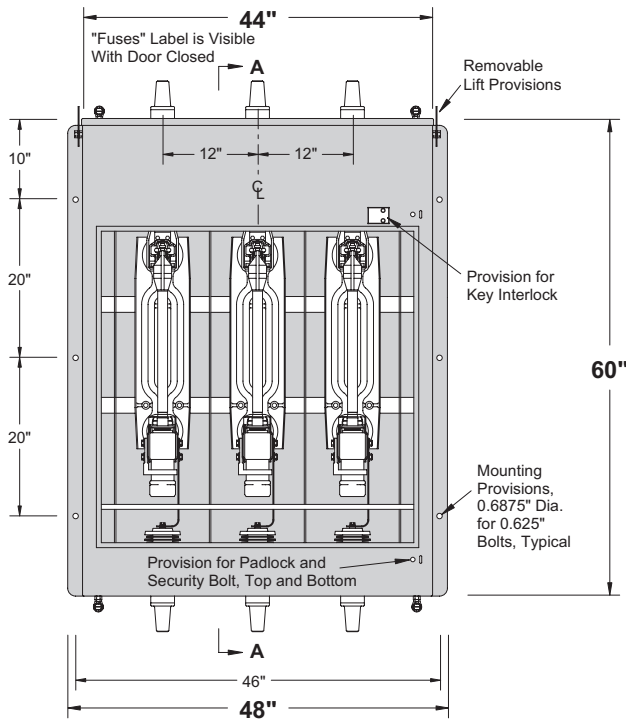

Front View

Door & Door Safety Barrier Removed

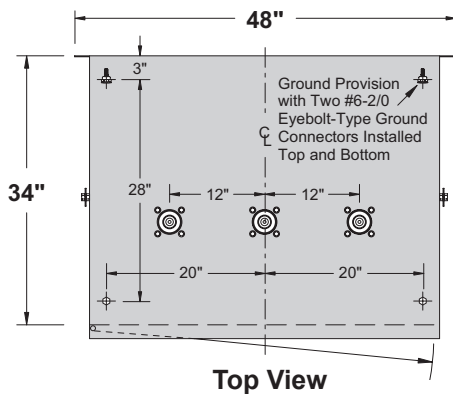

Top View

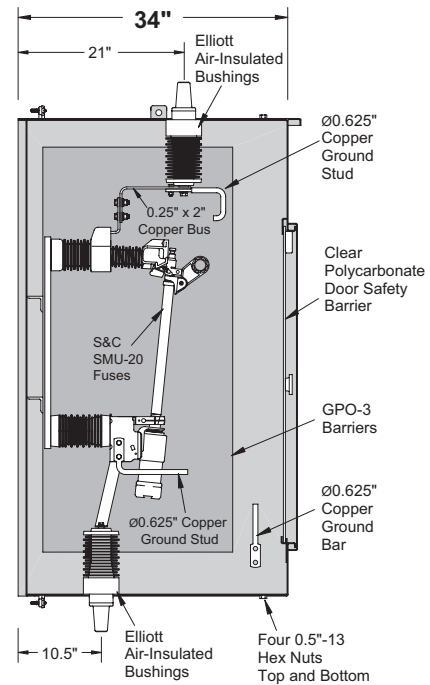

Section AA

- 11-Gauge Steel Enclosure
- Stainless Steel Hinges
- Provisions for Padlock and recessed Stainless Steel Penta-Head (or Hex-Head) Security Bolts
- Clear Polycarbonate Door Safety Barrier Standard
- 8" Min. Strike Distance to Ground
- 10" Min. Strike Distance Phase-to-Phase

- Standard Paint: "Pad-Mount Green" (Munsell #7GY 3.29/1.5)
- Optional Paint: "Light Grey" (Munsell #5BG 7.0/0.4)
- Option G1: Ground studs at main contact of fuse mounting
- Option G2: Ground studs at hinge end of fuse mounting
- Option K: Key interlock

Catalog Number	Fuse Mounting	Fuse End Fittings/Holder	Fuse Unit/Refill
EWMR-25-311S-E6TB-SM20	SM-20 without Uni-Rupter®	SM-20 / SML-20 Cat. #3097	SMU-20 200K or 200E Max
EWMR-25-311S-E6TB-SML20	SML-20 with Uni-Rupter®	SM-20 / SML-20 Cat. #3097	SMU-20 200K or 200E Max
EWMR-25-311S-E6TB-SMX4	SMX-4 without Uni-Rupter®	SML-4Z Cat. #92353	SM-4 200E Max
EWMR-25-311S-E6TB-SML4	SML-4Z with Uni-Rupter®	SML-4Z Cat. #92353	SM-4 200E Max

Uni-Rupter® is a registered trademark of S&C Electric Company.

NX® and X-Limiter™ are either registered trademarks or trademarks of Eaton in the U.S. and other countries.

Elastimold® is a registered trademark of ABB Asea Brown Boveri Ltd.

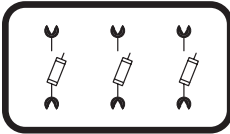

Three-Phase – Two Ways Per Phase

600 Amp Elliott Air-Insulated Bushings
15.2/26.3 kV Grounded Wye Max Design
125 kV BIL

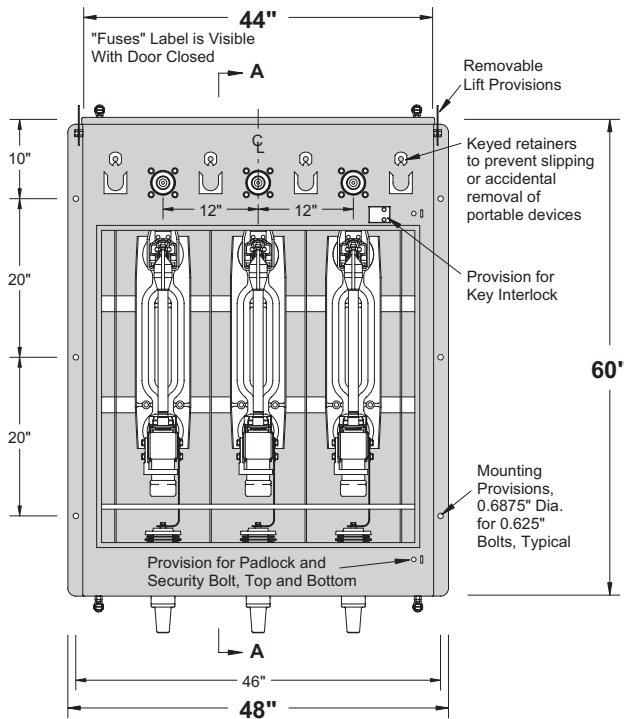

Front View

Door & Door Safety Barrier Removed

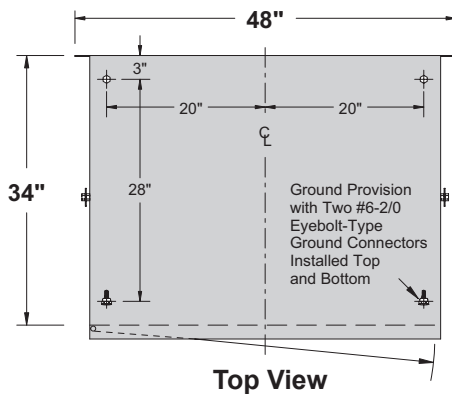

Top View

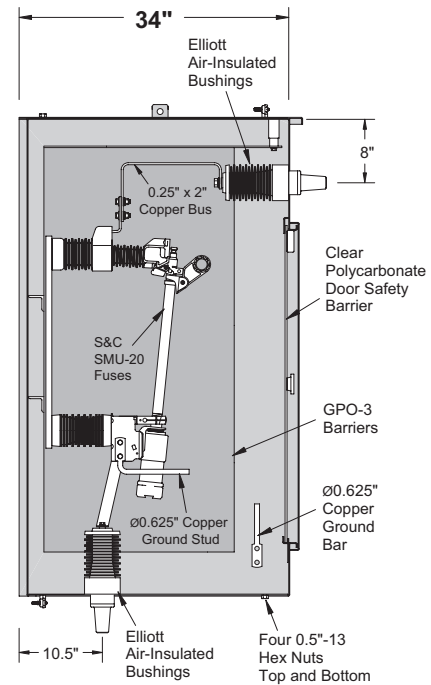

Section AA

- 11-Gauge Steel Enclosure
- Stainless Steel Hinges
- Provisions for Padlock and recessed Stainless Steel Penta-Head (or Hex-Head) Security Bolts
- Clear Polycarbonate Door Safety Barrier Standard
- 8" Min. Strike Distance to Ground
- 10" Min. Strike Distance Phase-to-Phase

- Standard Paint: "Pad-Mount Green" (Munsell #7GY 3.29/1.5)
- Optional Paint: " Light Grey" (Munsell #5BG 7.0/0.4)
- Option G2: Ground studs at hinge end of fuse mounting
- Option K: Key interlock

Catalog Number	Fuse Mounting	Fuse End Fittings/Holder	Fuse Unit/Refill
EWMR-25-311S-E6FB-SM20	SM-20 without Uni-Rupter®	SM-20 / SML-20 Cat. #3097	SMU-20 200K or 200E Max
EWMR-25-311S-E6FB-SML20	SML-20 with Uni-Rupter®	SM-20 / SML-20 Cat. #3097	SMU-20 200K or 200E Max
EWMR-25-311S-E6FB-SMX4	SMX-4 without Uni-Rupter®	SML-4Z Cat. #92353	SM-4 200E Max
EWMR-25-311S-E6FB-SML4	SML-4Z with Uni-Rupter®	SML-4Z Cat. #92353	SM-4 200E Max

Uni-Rupter® is a registered trademark of S&C Electric Company.

NX® and X-Limiter™ are either registered trademarks or trademarks of Eaton in the U.S. and other countries.

Elastimold® is a registered trademark of ABB Asea Brown Boveri Ltd.

Elliott Floor Support Frame For Wall-Mount Enclosure
Provides additional support when wall structure
is inadequate or questionable

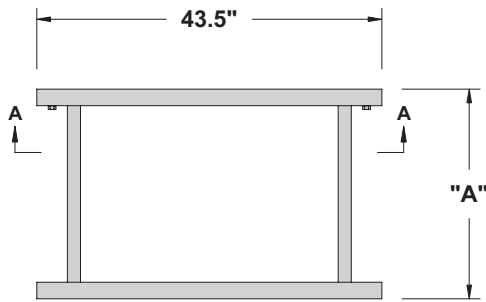

Front View

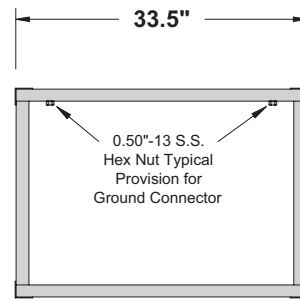

Side View

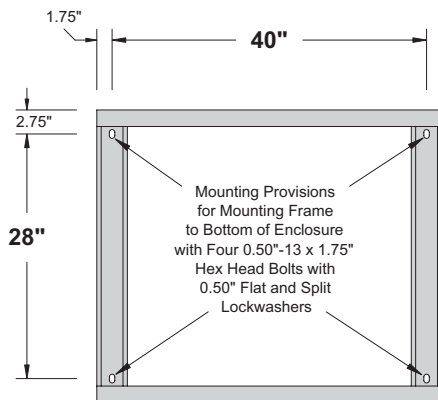

Top View

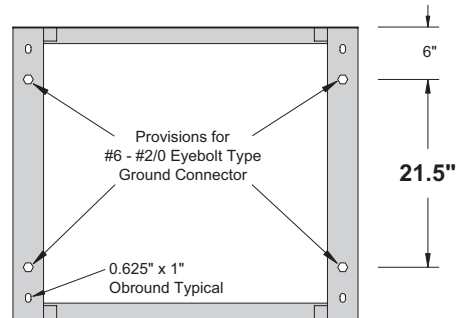

Section AA

11-Gauge Steel Frame
Standard Paint: "Pad-Mount Green" (Munsell #7GY 3.29/1.5)
Optional Paint: "Light Grey" (Munsell #5BG 7.0/0.4)

Catalog Number	Dimension "A"
EFSF-18-43.5-33.5	18"
EFSF-24-43.5-33.5	24"
EFSF-30-43.5-33.5	30"
EFSF-36-43.5-33.5	36"
EFSF-42-43.5-33.5	42"

Bushing Wells and Bushings

The wall-mount fuse gear shown in this bulletin is provided with Elliott 200 Amp Air-Insulated Bushing Wells and/or 600 Amp Air-Insulated Bushings which utilize the same mounting holes and mounting hardware. If circuit requirements change, 200 Amp Bushing Wells may be replaced with 600 Amp Bushings (600 Amp Bushings may be replaced with 200 Amp Bushing Wells).

NOTE: *The shipping cap on the Bushing Well or Bushing should be left in place to prevent contamination of the interface.*

NOTE: *The fuse gear must be de-energized and grounded in accordance with your company's normal safety procedure before any modifications are made.*

IMPORTANT: *Do not energize this bushing well or bushing with only the shipping cap in place.* To do so would lead to failure of this bushing and create a hazard to operating personnel. *This product is designed to be used only when it is mated with an appropriate 15 kV or 25 kV class bushing insert (or elbow) conforming to the latest revision of IEEE Standard 386.* The bushing insert (or elbow) should be installed in accordance with the instructions supplied by the connector manufacturer.

200 Amp Bushing Well #1101-225B

Voltage Class.....	25 kV
Phase-to-Ground Voltage.....	15.2 kV
BIL.....	125 kV
AC Withstand—1 Min. Dry.....	40 kV
10 Sec. Dew.....	40 kV
DC Withstand—15 Min. Dry.....	78 kV
Corona Extinction Level—Minimum.....	19 kV
Continuous Current.....	200 Amps
Momentary—RMS, Sym., 0.17 sec.....	10,000 Amps
RMS, Sym., 3 sec.....	3,500 Amps

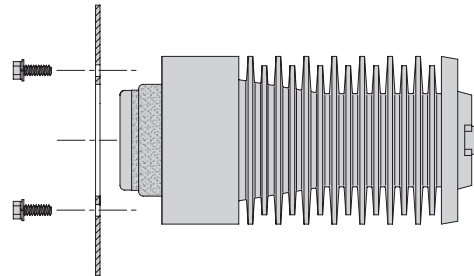

600 Amp Bushing #1201-625B2

Voltage Class.....	25 kV
Phase-to-Ground Voltage.....	15.2 kV
BIL.....	125 kV
AC Withstand—1 Min. Dry.....	40 kV
10 Sec. Dew.....	40 kV
DC Withstand—15 Min. Dry.....	78 kV
Corona Extinction Level—Minimum.....	19 kV
Continuous Current.....	600 Amps
Momentary—RMS, Sym., 0.17 sec.....	25,000Amps
RMS, Sym., 3 sec.....	10,000 Amps

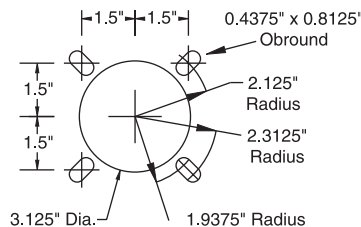
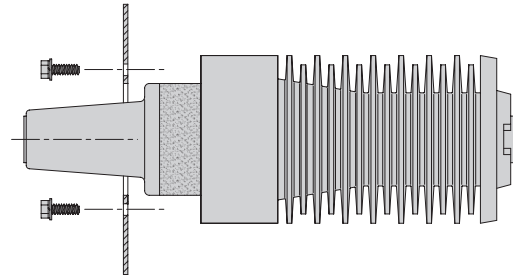

Uni-Mount Mounting Holes Accepts Elliott and S&C Bushings

Uni-Rupter® is a registered trademark of S&C Electric Company.

NX® and X-Limiter™ are either registered trademarks or trademarks of Eaton in the U.S. and other countries.

Elastimold® is a registered trademark of ABB Asea Brown Boveri Ltd.

Typical Specification - Page 1 of 3

General

The fuse-gear shall be 25 kV class, 125 kV BIL, 600 ampere continuous current, suitable for use on 15.2/26.3 kV grounded wye max design systems. The enclosure shall be designed for wall mounting and shall include provisions to accept a floor support frame that may be specified when a wall structure is questionable or inadequate to support the fuse-gear. The fuse-gear shall be constructed for connection to the utility system with separable insulated connectors as described in IEEE Standard 386—latest revision (separable insulated connectors [and loadbreak inserts when required] shall be supplied by the user). The fuse-gear shall be designed for and contain three fuse mountings as described below. A door safety barrier shall be provided inside the door on the fuse compartment as recommended in IEEE Standard C2 (National Electrical Safety Code) Rule 381G. Tamper resistance shall meet the Enclosure Security requirements of IEEE Standard C57.12.28 (Pad-Mounted Equipment—Enclosure Integrity). Together, the tamper resistance and the door safety barrier shall resist unauthorized entry, protect authorized and unauthorized persons, and provide positive safety features when installed in areas accessible to the general public. The fuse-gear shall be constructed for indoor/outdoor installation in areas subject to precipitation and in areas with windblown contamination. The equipment shall be “air-insulated” and completely assembled prior to shipment.

Enclosure Construction

The enclosure shall be tamper-resistant, all-welded construction utilizing 11-gauge minimum sheet steel. Single and double 90-degree bends shall be used as necessary to assure strength and rigidity. The enclosure top shall be kinked to provide watershed and rigidity. The fuse compartment access door shall be furnished with a stainless steel door holder that will latch the door open 100 degrees and 140 degrees and resist accidental closing. The door shall be provided with provisions for padlocking and a recessed penta-head (or hex-head) security bolt to prevent unauthorized entry (coordinated to prevent installation of the padlock until the security bolt is tightened *when closing the door(s)* and to prevent a wrench from operating the security bolt until the padlock is removed *when opening the door(s)*). The security bolt shall be made captive with a stainless steel washer compressed to an oval shape to severely discourage removal. Hinges shall be stainless steel (with stainless steel pins not less than 0.3125-inch diameter) and shall be welded to both the enclosure and the door to maintain door alignment for the life of the equipment. The

enclosure shall be nonventilated to minimize the entrance of airborne contamination, insects, rodents or reptiles. The protective finish shall include necessary grinding, cleaning and phosphatizing, two-component rust-inhibiting epoxy primer and a Pad-Mount Green two-component polyurethane top coat finish—Munsell color 7GY 3.29/1.5 (or Optional Grey—Munsell color 5BG 7.0/0.4). The primer and top coat shall be electronically monitored during application to insure proper ratio and mixing of each component. Total average thickness of paint (after curing) shall be not less than 5 mils. The protective coating shall meet the Enclosure Coating System requirements of IEEE Standard C57.12.28 (Pad-Mounted Equipment—Enclosure Integrity). Removable lift provisions, adequate to withstand handling with normal utility equipment, shall be provided on the outside of the enclosure. Threaded openings for lift provision bolts shall be blind holes to prevent the entrance of wire or other foreign objects into the enclosure when lift provisions are removed.

Four threaded openings for attachment of a floor support frame (to provide additional support when a wall structure is questionable or inadequate) shall be provided on the bottom of the enclosure. The threaded openings shall be blind holes and shall be unpainted internally to provide a ground for the floor support frame that may be installed. When specified, an 18-inch (alternate 24-inch, 30-inch, 36-inch or 42-inch) high floor support frame shall be supplied bolted in place with stainless steel hardware. The floor support frame shall be all-welded construction utilizing 11-gauge minimum sheet steel formed to assure strength and rigidity. The two ground lugs specified for the bottom of the enclosure shall be installed on the floor support frame not more than 6 inches from the original location. The protective coating of the floor support frame shall meet or exceed the coating requirements specified above for the enclosure.

Bushings and Terminals

Alternate 1: Bushings shall be 200 ampere Elliott #1101-225B, 25 kV class (15.2 kV to ground) Air-Insulated Bushing Wells, 125 kV BIL, per IEEE Standard 386 Fig. 3 (200 A Bushing Well Interface, 8.3 kV, 15.2 kV and 21.1 kV) *for use with either 8.3/14.4 kV or 15.2/26.3 kV separable insulated connectors* (Elastimold®, Eaton’s Cooper Power Systems or other approved equal). The bushing wells shall be pressure-molded cycloaliphatic epoxy with a 0.75-inch diameter copper conductor on the “air-insulated” side that is drilled and tapped 0.375-inch – 16UNC x 1-inch deep to provide direct connection of the bus and/or live parts. Leakage distance from the apparatus connection end of the bushing well to ground shall be not less than 30 inches to

Typical Specification - Page 2 of 3

assure trouble-free operation in a wet and/or contaminated environment. Integral shielding shall be provided to eliminate partial discharge caused by off-center mounting and mounting holes that may have sharp edges or burrs. Bushing wells shall mount in a 3.125-inch diameter opening and bolt in place to allow field replacement with standard tools. The bushing well mounting bolts shall be self-locking stainless steel serrated-flange hex-head bolts that “cut” through the enclosure protective finish to ground the integral shielding of each bushing well. The head of one or more of the mounting bolts for each bushing well shall include a 0.156-inch diameter hole to provide a connection to ground for the loadbreak insert shielding ground wire as recommended by separable insulated connector manufacturers. To assure adequate strength for apparatus support, the bushing well shall withstand a minimum cantilever loading of 600 pounds for five minutes without damage. The bushing well interface shall be free of all voids, holes and heat sinks to assure proper mating with separable insulated connectors. Each bushing well shall be tested in free air, mounted in a grounded steel plate not less than 10 inches x 10 inches, with a bushing well plug (Eaton’s Cooper Power Systems #IBWP225 or equal) installed in the well interface to accurately simulate operating conditions (*gas or liquid dielectric in the interface shall not be acceptable for this test*). Each bushing well shall meet the requirements for 25 kV devices in accordance with IEEE Standard 386 (latest revision), including 100 percent production testing.

Alternate 2: Bushings shall be 600 ampere Elliott #1201-625B2, 25 kV class (15.2 kV to ground) Air-Insulated Bushings, 125 kV BIL, per IEEE Standard 386 Fig. 11 (600 A Deadbreak Interface No. 1, 8.3 kV and 15.2 kV) for use with either 8.3/14.4 kV or 15.2/26.3 kV separable insulated connectors (Elastimold®, Eaton’s Cooper Power Systems or other approved equal). The bushings shall be pressure-molded cycloaliphatic epoxy with a 1.25-inch diameter tin-plated aluminum conductor on the “air-insulated” side that is drilled and tapped 0.625-inch – 11UNC x 1-inch deep to provide direct connection of the bus and/or live parts. Leakage distance from the apparatus connection end of the bushing to ground shall be not less than 30 inches to assure trouble-free operation in a wet and/or contaminated environment. Integral shielding shall be provided to eliminate partial discharge caused by off-center mounting and mounting holes that may have sharp edges or burrs. Bushings shall mount in a 3.125-inch diameter opening and bolt in place to allow field replacement with standard tools. The bushing mounting bolts shall be self-locking stainless steel serrated-flange hex-head bolts that “cut” through the enclosure protective finish to ground the integral shielding of each bushing. To assure

adequate strength for apparatus support, the bushing shall withstand a minimum cantilever loading of 600 pounds for five minutes without damage. The bushing interface shall be free of all voids, holes and heat sinks to assure proper mating with separable insulated connectors. Each bushing shall be tested in free air, mounted in a grounded steel plate not less than 10 inches x 10 inches, with an insulated protective cap (Eaton’s Cooper Power Systems #DPC625 or equal) installed on the interface to accurately simulate operating conditions (*gas or liquid dielectric on the interface shall not be acceptable for this test*). Each bushing shall meet the requirements for 25 kV devices in accordance with the test values of IEEE Standard 386 (latest revision), including 100 percent production testing.

Fuse Mountings

Fuse clips and/or fuse hinges shall be keyed to prevent rotation and to maintain alignment. Positive pressure shall be assured by use of stainless steel fasteners and lock washers or compression washers at all connection points. All connections shall provide direct contact of current-carrying parts and shall not depend on current transfer through fastener thread-to-thread contact. Fuses and their blown-fuse indicators shall be visible (*when the fuse compartment door is open without removal of the clear-polycarbonate door safety barrier*) to allow easy identification of blown fuses without de-energizing or removing the fuse from service. Electrical components shall be “air-insulated” and positioned to allow visual inspection of all internal connections and components *without removing the clear-polycarbonate door safety barrier*, de-energizing or removing the equipment from service. *When Option G1 is specified*, ground studs shall be provided for each terminal at the top of the fuse mounting. *When Option G2 is specified*, ground studs shall be provided for each terminal at the bottom of the fuse mounting.

Alternate 1: Fuse provisions *without* S&C Uni-Rupter® shall accommodate S&C Fuse-Unit End Fittings Type SM-20/SML-20. Fuse-Unit End Fittings, when supplied, shall accept 200 amp (max) Type SMU-20 fuse units. (*When this alternate is selected, loadbreak operations must be accomplished with loadbreak elbows*). A Warning Sign, Elliott #7201-W2003-318, shall be provided inside the fuse compartment door to warn the operator to “Park the load side cable before installing or removing fuses.” A Danger Sign, Elliott #7203-D2003-313, shall be provided in a prominent location near the fuse clips to warn the operator “Do not remove fuse under load.”

Alternate 2: Fuse provisions with S&C Uni-Rupter® shall accommodate S&C Fuse-Unit End Fittings Type

Typical Specification - Page 3 of 3

SM-20/SML-20. Fuse-Unit End Fittings, when supplied, shall accept 200 amp (max) Type SMU-20 fuse units.

Alternate 3: Fuse provisions *without* S&C Uni-Rupter® shall accommodate S&C Fuse Holder Type SML-4Z. Fuse holders, when supplied, shall accept 200 amp (max) Type SM-4 fuse refills. (*When this alternate is selected, loadbreak operations must be accomplished with loadbreak elbows*). A Warning Sign, Elliott #7201-W2003-318, shall be provided inside the fuse compartment door to warn the operator to "Park the load side cable before installing or removing fuses." A Danger Sign, Elliott #7203-D2003-313, shall be provided in a prominent location near the fuse clips to warn the operator "Do not remove fuse under load."

Alternate 4: Fuse provisions with S&C Uni-Rupter® shall accommodate S&C Fuse Holder Type SML-4Z. Fuse holders, when supplied, shall accept 200 amp (max) Type SM-4 fuse refills.

Bus

Bus shall be copper with all burrs and sharp corners removed prior to installation. Positive pressure shall be assured by use of stainless steel fasteners and lock washers at all connection points. All connections shall provide direct contact of current-carrying parts and shall not depend on current transfer through fastener thread-to-thread contact. Electrical components shall be "air-insulated" and positioned to allow visual inspection of all internal connections and components *without removing the clear-polycarbonate door safety barrier*, de-energizing or removing the equipment from service.

Barriers

Phase and ground barriers shall be provided to assure correct phase-to-phase and phase-to-ground clearances for proper operation at rated voltage. These barriers shall be glass-reinforced polyester (NEMA GPO-3 class material) not less than 0.1875-inch thick.

A removable insulating barrier with a "DANGER – Keep Out! – Hazardous voltage" sign, Elliott #7203-D2003-309, shall be located inside the door(s) on the fuse compartment as recommended in Rule 381G of IEEE Standard C2 (National Electrical Safety Code). This door safety barrier shall be constructed of 0.25-inch clear-polycarbonate (Lexan or equal) and shall completely close the door opening and be provided with a nonconductive safety latch requiring a positive action to remove the barrier. Handles and other hardware extending through this door safety barrier shall be nonconductive material. Handles shall be keyed to prevent rotation for secure handling. *Complete visual inspection of the internal components shall be possible without removing the door safety barrier.*

Grounding Provisions

Four high-conductivity bronze eyebolt-type ground lugs, which accept #6 through #2/0 copper conductor, shall be installed on the enclosure (two on the exterior of the top and two on the exterior of the bottom). One 0.625-inch diameter copper grounding bar that bolts to both walls inside the enclosure shall be provided near the bottom of the door opening in a position easily accessible for attachment of grounding clamps. When grounding clamps are installed it shall be possible to close and lock the door.

Accessory Equipment

Stainless steel parking stands shall be provided in the quantity required to allow use of feed-thru bushings, parking bushings and grounding bushings. The parking stands shall be welded in place, in a position to allow the use of hot-line tools for installation of feed thru-bushings, etc. The parking stands shall be *unpainted* (except welds shall be painted) to provide a ground for feed-thru bushings and other devices that may be placed into the parking stands. *Keyed retainers* shall be welded above each parking stand to prevent slipping or accidental removal of portable devices such as feed-thru bushings, etc.

A corrosion proof nameplate with permanent thermal transfer printing shall be installed inside the compartment door. It shall be located at the top corner farthest from the enclosure when the door is open. The nameplate will provide Type of Equipment, Model Number, Amps Continuous, kV Maximum, BIL, Serial Number, Job Number, Date Manufactured and Weight of Equipment.

The enclosure shall be labeled in near proximity of the locking provisions with a pressure-sensitive vinyl label using letters not less than 0.375-inch nor more than 0.625-inch high. The label shall indicate the type of equipment behind the access (switch, fuses, bus, etc.).

Packaging

Each enclosure shall be bolted to a solid-top wood pallet (to prevent the forks of a forklift truck from entering the open bottom of the equipment) to prevent hidden damage. The equipment shall be wrapped with 0.125-inch thick polyethylene foam or other suitable material to minimize damage to the finish during shipment.

Drawings

When specified, drawings shall be furnished for each fuse-gear that include:

- 1) enclosure dimensions and location of components.
- 2) proposed labels and location of labels.