



25-kV Apparatus Bushings

“C” Series (bolt-in) for Elbow to Air-Insulated Service

200 Amp

Descriptive
Bulletin
1025-230
Page 1 2015

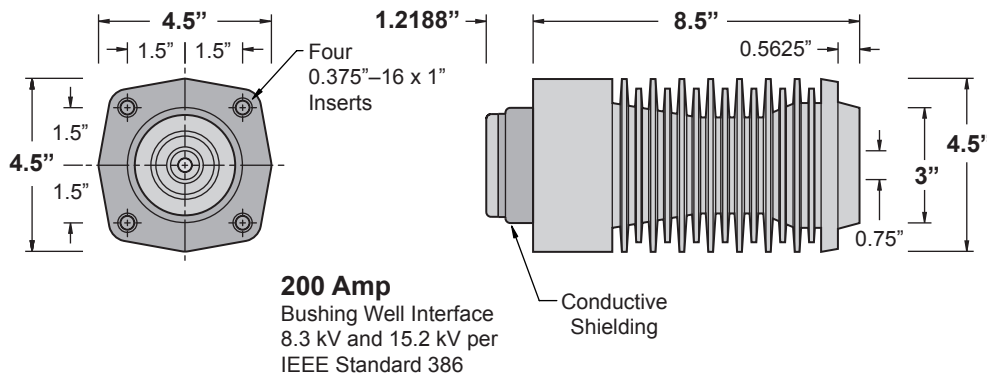

200 Amp Bushing Well #1301-225C

<table border="0" style="width: 100%;"> <tr><td>Voltage Class.....</td><td>25 kV</td></tr> <tr><td>Phase-to-Ground Voltage.....</td><td>15.2 kV</td></tr> <tr><td>BIL.....</td><td>125 kV</td></tr> <tr><td>AC Withstand - 1 Min. Dry.....</td><td>40 kV</td></tr> <tr><td> 10 Sec. Dew.....</td><td>40 kV</td></tr> <tr><td>DC Withstand - 15 Min. Dry.....</td><td>78 kV</td></tr> <tr><td>Corona Extinction Level - Minimum.....</td><td>>19 kV</td></tr> <tr><td>Continuous Current.....</td><td>200 Amps</td></tr> <tr><td>Momentary - RMS, Sym., 0.17 sec.....</td><td>10,000 Amps</td></tr> <tr><td> RMS, Sym., 3 sec.....</td><td>3,500 Amps</td></tr> </table>	Voltage Class.....	25 kV	Phase-to-Ground Voltage.....	15.2 kV	BIL.....	125 kV	AC Withstand - 1 Min. Dry.....	40 kV	10 Sec. Dew.....	40 kV	DC Withstand - 15 Min. Dry.....	78 kV	Corona Extinction Level - Minimum.....	>19 kV	Continuous Current.....	200 Amps	Momentary - RMS, Sym., 0.17 sec.....	10,000 Amps	RMS, Sym., 3 sec.....	3,500 Amps	<table border="0" style="width: 100%;"> <tr><td>Leakage Distance, Inches.....</td><td>28</td></tr> <tr><td>Dry Arcing Distance, Inches.....</td><td>8.5</td></tr> <tr><td>Mechanical - Strength Rating, Pounds</td><td></td></tr> <tr><td> Cantilever, Ultimate 2.5 inches past end.....</td><td>>1,000</td></tr> <tr><td> Tensile, Pounds.....</td><td>>5,000</td></tr> <tr><td> Torsion, Inches-Pounds (bolt breaks).....</td><td>>1,000</td></tr> <tr><td> Compression, Pounds.....</td><td>20,000</td></tr> <tr><td>Insert Thread Size.....</td><td>0.375"-16 x 1"</td></tr> <tr><td>Conductor (live end) Thread Size.....</td><td>0.375"-16 x 1"</td></tr> <tr><td>Net Weight, Pounds (kg).....</td><td>6.75 (3.06)</td></tr> </table>	Leakage Distance, Inches.....	28	Dry Arcing Distance, Inches.....	8.5	Mechanical - Strength Rating, Pounds		Cantilever, Ultimate 2.5 inches past end.....	>1,000	Tensile, Pounds.....	>5,000	Torsion, Inches-Pounds (bolt breaks).....	>1,000	Compression, Pounds.....	20,000	Insert Thread Size.....	0.375"-16 x 1"	Conductor (live end) Thread Size.....	0.375"-16 x 1"	Net Weight, Pounds (kg).....	6.75 (3.06)
Voltage Class.....	25 kV																																								
Phase-to-Ground Voltage.....	15.2 kV																																								
BIL.....	125 kV																																								
AC Withstand - 1 Min. Dry.....	40 kV																																								
10 Sec. Dew.....	40 kV																																								
DC Withstand - 15 Min. Dry.....	78 kV																																								
Corona Extinction Level - Minimum.....	>19 kV																																								
Continuous Current.....	200 Amps																																								
Momentary - RMS, Sym., 0.17 sec.....	10,000 Amps																																								
RMS, Sym., 3 sec.....	3,500 Amps																																								
Leakage Distance, Inches.....	28																																								
Dry Arcing Distance, Inches.....	8.5																																								
Mechanical - Strength Rating, Pounds																																									
Cantilever, Ultimate 2.5 inches past end.....	>1,000																																								
Tensile, Pounds.....	>5,000																																								
Torsion, Inches-Pounds (bolt breaks).....	>1,000																																								
Compression, Pounds.....	20,000																																								
Insert Thread Size.....	0.375"-16 x 1"																																								
Conductor (live end) Thread Size.....	0.375"-16 x 1"																																								
Net Weight, Pounds (kg).....	6.75 (3.06)																																								

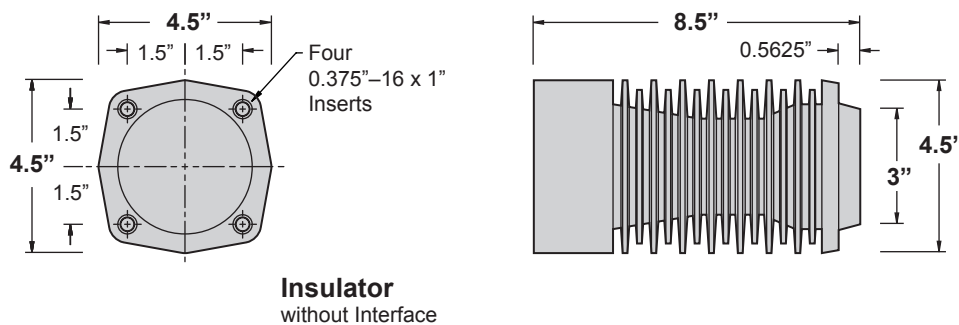

Bushing-Style Insulator #1801-025C

<table border="0" style="width: 100%;"> <tr><td>Voltage Class.....</td><td>25 kV</td></tr> <tr><td>Phase-to-Ground Voltage.....</td><td>15.2 kV</td></tr> <tr><td>BIL.....</td><td>125 kV</td></tr> <tr><td>AC Withstand - 1 Min. Dry.....</td><td>40 kV</td></tr> <tr><td> 10 Sec. Dew.....</td><td>40 kV</td></tr> <tr><td>DC Withstand - 15 Min. Dry.....</td><td>78 kV</td></tr> <tr><td>Corona Extinction Level - Minimum.....</td><td>>19 kV</td></tr> <tr><td>Continuous Current.....</td><td>N/A</td></tr> <tr><td>Momentary - RMS, Sym., 0.17 sec.....</td><td>N/A</td></tr> <tr><td> RMS, Sym., 3 sec.....</td><td>N/A</td></tr> </table>	Voltage Class.....	25 kV	Phase-to-Ground Voltage.....	15.2 kV	BIL.....	125 kV	AC Withstand - 1 Min. Dry.....	40 kV	10 Sec. Dew.....	40 kV	DC Withstand - 15 Min. Dry.....	78 kV	Corona Extinction Level - Minimum.....	>19 kV	Continuous Current.....	N/A	Momentary - RMS, Sym., 0.17 sec.....	N/A	RMS, Sym., 3 sec.....	N/A	<table border="0" style="width: 100%;"> <tr><td>Leakage Distance, Inches.....</td><td>28</td></tr> <tr><td>Dry Arcing Distance, Inches.....</td><td>8.5</td></tr> <tr><td>Mechanical - Strength Rating, Pounds</td><td></td></tr> <tr><td> Cantilever, Ultimate 2.5 inches past end.....</td><td>>1,000</td></tr> <tr><td> Tensile, Pounds.....</td><td>>5,000</td></tr> <tr><td> Torsion, Inches-Pounds (bolt breaks).....</td><td>>1,000</td></tr> <tr><td> Compression, Pounds.....</td><td>20,000</td></tr> <tr><td>Insert Thread Size.....</td><td>0.375"-16 x 1"</td></tr> <tr><td>Live End Thread Size.....</td><td>0.375"-16 x 1"</td></tr> <tr><td>Net Weight, Pounds (kg).....</td><td>5.82 (2.64)</td></tr> </table>	Leakage Distance, Inches.....	28	Dry Arcing Distance, Inches.....	8.5	Mechanical - Strength Rating, Pounds		Cantilever, Ultimate 2.5 inches past end.....	>1,000	Tensile, Pounds.....	>5,000	Torsion, Inches-Pounds (bolt breaks).....	>1,000	Compression, Pounds.....	20,000	Insert Thread Size.....	0.375"-16 x 1"	Live End Thread Size.....	0.375"-16 x 1"	Net Weight, Pounds (kg).....	5.82 (2.64)
Voltage Class.....	25 kV																																								
Phase-to-Ground Voltage.....	15.2 kV																																								
BIL.....	125 kV																																								
AC Withstand - 1 Min. Dry.....	40 kV																																								
10 Sec. Dew.....	40 kV																																								
DC Withstand - 15 Min. Dry.....	78 kV																																								
Corona Extinction Level - Minimum.....	>19 kV																																								
Continuous Current.....	N/A																																								
Momentary - RMS, Sym., 0.17 sec.....	N/A																																								
RMS, Sym., 3 sec.....	N/A																																								
Leakage Distance, Inches.....	28																																								
Dry Arcing Distance, Inches.....	8.5																																								
Mechanical - Strength Rating, Pounds																																									
Cantilever, Ultimate 2.5 inches past end.....	>1,000																																								
Tensile, Pounds.....	>5,000																																								
Torsion, Inches-Pounds (bolt breaks).....	>1,000																																								
Compression, Pounds.....	20,000																																								
Insert Thread Size.....	0.375"-16 x 1"																																								
Live End Thread Size.....	0.375"-16 x 1"																																								
Net Weight, Pounds (kg).....	5.82 (2.64)																																								

Production Tests

Every bushing is production tested in free air, mounted in an 11-gauge grounded steel plate not less than 10 inches x 10 inches, with an insulating protective plug installed in the interface to accurately simulate operating conditions. Each bushing must meet or exceed the requirements for 15.2/26.3 kV devices in accordance with the test values of IEEE Standard 386 (latest revision) for partial discharge (corona) and AC voltage withstand when tested in this manner.

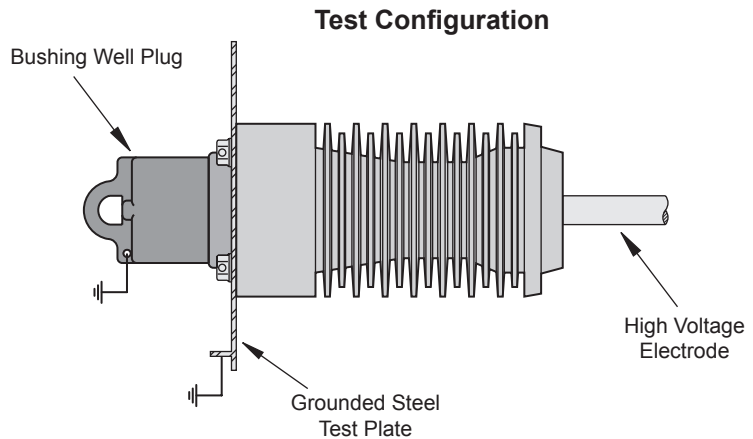

Installation Instructions

Elliott "C" Series Apparatus Bushings require a 3.125" diameter mounting hole with four 0.4375" diameter bolt holes. The bushing bolts in place utilizing four 0.375-inch-16UNC x 1" serrated-flange hex-head bolts (or bolts with external tooth lock washers). All mounting hardware is located on the elbow side of the equipment mounting plate to eliminate the possibility of reduced phase-to-ground clearance.

1. The bushing installs from the rear (live) side for easy installation.
2. Serrated-flange bolts (or bolts and external tooth lock washers) are installed. The bolts should be tightened in a uniform manner (rather than one-by-one in a random sequence). Do not apply more than 90 inch-pounds torque to each bolt. The serrated-flange bolts (or external tooth lock washers) must "cut" into the mounting plate to provide a connection from the shielding to the grounded mounting plate. If the bushing is mounted on an ungrounded or insulated plate (such as fiberglass) a ground strap should be attached to one of the mounting bolts.

Every Elliott Bushing is tested at the factory, mounted in a grounded steel plate. A greased bushing well plug is installed in the interface to accurately simulate operating conditions. To prevent contamination of the silicone grease, it is important to keep the shipping cap in place until you are ready to install the bushing insert. Should the grease become contaminated, thoroughly clean the interface and reapply silicone grease before installing the bushing insert.

NOTE: *The shipping cap on the bushing well should be left in place to prevent contamination of the interface.*

IMPORTANT:

Do not energize this bushing with only the shipping cap in place. To do so would lead to failure of the bushing and create a hazard to operating personnel. This product is designed to be used **only** when it is mated with an appropriate 15 kV or 25 kV Class bushing insert conforming to the latest revision of IEEE Standard 386. The bushing insert should be installed in accordance with the instructions supplied by the connector manufacturer.

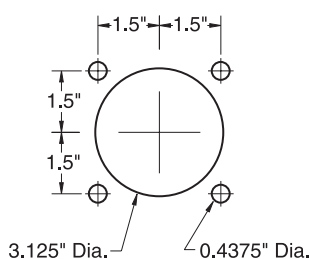

**Standard Mounting Holes
for Elliott "B" Series Bushings**

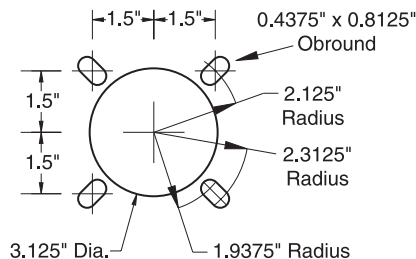

**Uni-Mount Mounting Holes
Accepts Elliott and S&C Bushings**

