

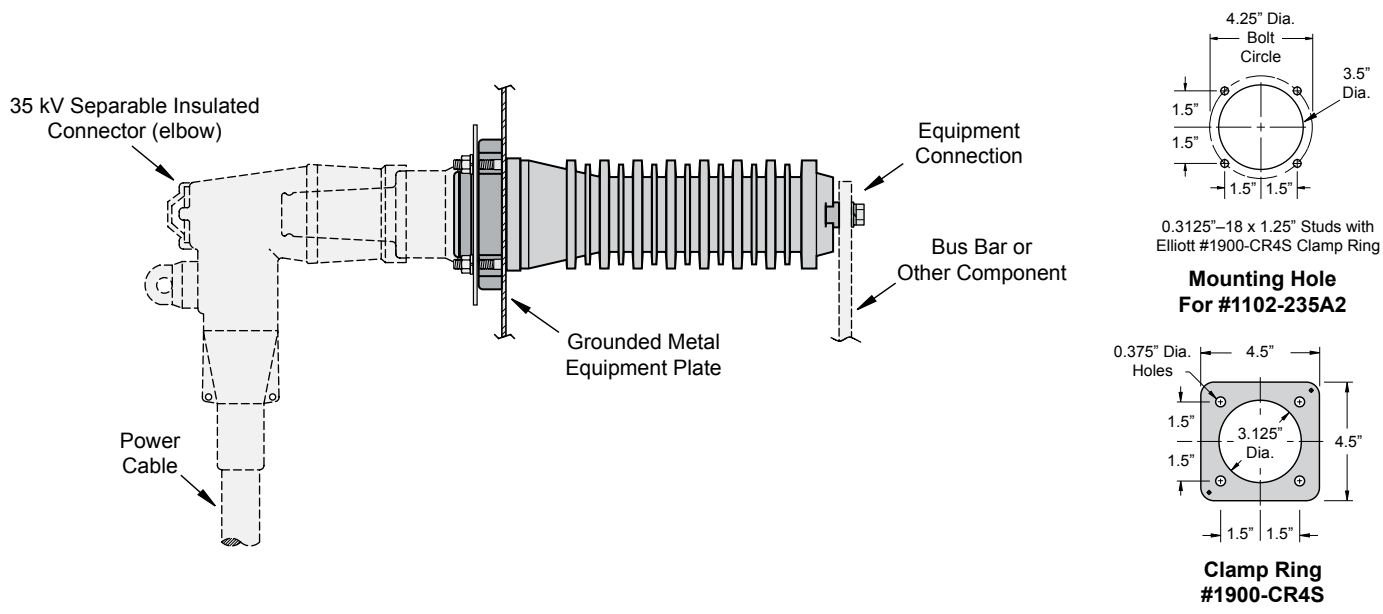

35-kV Apparatus Bushing

"A" Series (clamp-in) for Elbow to Air-Insulated Service
200 Amp

Descriptive
Bulletin
1135-200
Page 1 2018



ELRIM Cycloaliphatic Epoxy Provides:

- Nontracking, self-scouring, nonweathering performance
- Superior dielectric strength, dielectric loss and power factor
- Choice of shapes allows design innovation
- Mechanical and thermal toughness
- Shatter-free arc flashover performance
- Oil resistant

Elliott Design Provides:

- Precision molded interfaces per IEEE Standard 386
- Integral shielding to prevent destructive corona discharge
- Square-edge skirts resist contamination - wet or dry
- Generous dry arcing (strike) distance
- Large diameter live end terminal pad with female threads for direct contact of current-carrying parts and improved corona performance
- Thermal cycle withstand from +200° to -200° F for long life
- High Strength - field proven performance since 1975

For 35-kV Connectors (Elbows)

Elliott "A" Series (clamp-in) apparatus bushings are used to construct air-insulated equipment that connects to the utility's underground shielded cable system with IEEE Standard separable insulated connectors (i.e. elbows). Integral shielding prevents "edge-of-hole" corona discharge. The live side of the bushing is provided with unique square-edge skirts to resist flashover when contaminated and wet. The large diameter live end terminal pad (with female threads) provides for direct contact of current-carrying parts and eliminates exposed sharp threads, which could induce destructive corona discharge. In addition to IEEE Standard 386 design tests, Elliott bushings are design tested for thermal cycle withstand from +200° to -200° F to assure long field life. Every bushing is production tested "in-air" mounted in a grounded steel plate with an insulated protective plug (or cap) installed on the interface to accurately simulate operating conditions.

Ratings and Dimensions of Bushing Wells

Catalog Number	Voltage Class kV	Continuous Current Amps	Withstand Test Voltage Kilovolts			Minimum Leakage Inches	Minimum Strike Inches
			Impulse 1.2 x 50	One Min. Dry	10 Sec. Dew		
1102-235A2 Bushing Well	35	200	150	50	50	21	10

Elastimold® is a registered trademark of ABB Asea Brown Boveri Ltd.



35-kV Apparatus Bushing

“A” Series (clamp-in) for Elbow to Air-Insulated Service
200 Amp

Descriptive
Bulletin
1135-200
Page 2 2018

200 Amp Bushing Well #1102-235A2

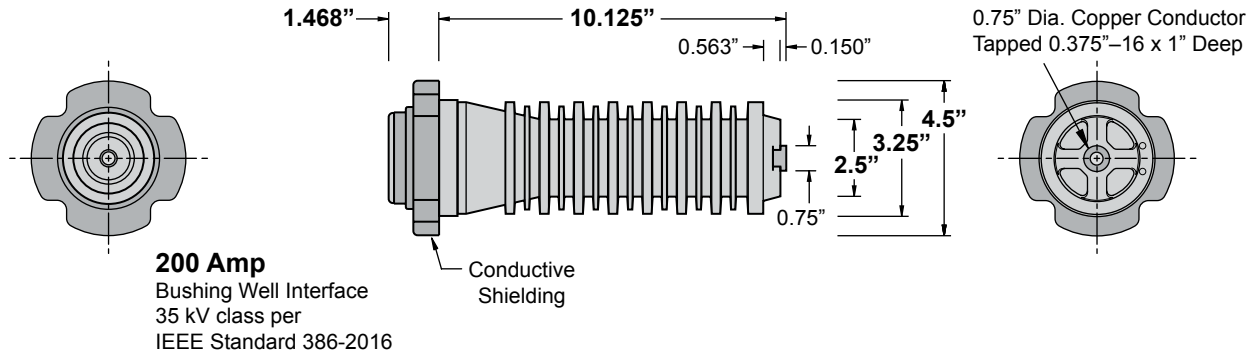

Voltage Class.....	35 kV
Phase-to-Ground Voltage.....	21.1 kV
BIL.....	150 kV
AC Withstand - 1 Min. Dry.....	50 kV
10 Sec. Dew.....	50 kV
DC Withstand - 15 Min. Dry.....	103 kV
Corona Extinction Level - Minimum.....	26 kV
Continuous Current.....	200 Amps
Momentary - RMS, Sym., 0.17 sec.....	10,000 Amps
RMS, Sym., 3 sec.....	3,500 Amps

Leakage Distance, Inches.....	21
Dry Arcing Distance, Inches.....	10
Mechanical - Strength Rating, Pounds	
Cantilever, Ultimate 2.5 inches past end.....	>250
Tensile, Pounds.....	>2,500
Torsion, Inches-Pounds (bolts breaks).....	>700
Copression, Pounds.....	20,000
Conductor (live end) Thread Size.....	0.375"-16 x 1"
Net Weight, Pounds (kg).....	5.37 (2.44)

The #1102-235A2 bushing well is a large-shank design that uses the same mounting bolt pattern and clamp ring as the small-shank bushing, but requires a larger mounting hole.

Typical Specifications - 200 Amp 35-kV Bushing Wells

Bushings shall be 200 ampere Elliott #1102-235A2, 35 kV Class (21.1 kV to ground) Air-Insulated Bushing Wells, 150 kV BIL, per IEEE Standard 386-2016 Fig. 3 (Interface 3: a 200 A bushing well interface) for use with 21.1/36.6 kV separable insulated connectors (Elastimold® or other approved equal). The bushing wells shall be pressure-molded cycloaliphatic epoxy with a 0.75-inch diameter copper conductor on the “air-insulated” side that is drilled and tapped 0.375-inch-16UNC x 1-inch deep to provide direct connection of the bus and/or live parts. Leakage distance from the apparatus connection end of the bushing well to ground shall be not less than 21 inches to assure trouble-free operation in a wet and/or contaminated environment. Conductive shielding with an insulating overlay shall be provided which completely shields the mounting hole to eliminate partial discharge caused by off-center mounting and mounting holes that may have sharp edges or burrs.

Bushing wells shall mount in a 3.5-inch diameter opening and clamp in place to allow field replacement with standard tools. To assure adequate strength for apparatus support, the bushing well shall withstand a minimum cantilever loading of 150 pounds for five minutes without damage. The bushing well interface shall be free of all voids, holes and heat sinks to assure proper mating with separable insulated connectors. Each bushing well shall be tested in free air, mounted in a grounded steel plate not less than 10 inches x 10 inches and with a bushing well plug (Elastimold® #M276BWP or equal) installed in the well interface to accurately simulate operating conditions (*gas or liquid dielectric in the interface shall not be acceptable for this test*). Each bushing shall meet the requirements for 35 kV devices in accordance with IEEE Standard 386 (latest revision), including 100 percent production testing.

Mounting Hole For #1102-235A2

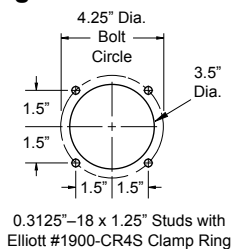

Clamp Ring #1900-CR4S

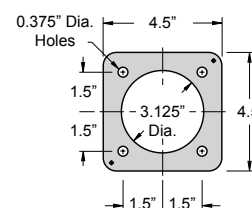

Elastimold® is a registered trademark of ABB Asea Brown Boveri Ltd.

Production Tests

Every bushing is production tested in free air, mounted in an 11-gauge grounded steel plate not less than 10 inches x 10 inches, with an insulating protective plug installed on the interface to accurately simulate operating conditions. Each bushing must meet or exceed the requirements for 21.1/36.6 kV devices in accordance with the test values of IEEE Standard 386 (latest revision) for partial discharge (corona) and AC voltage withstand when tested in this manner.

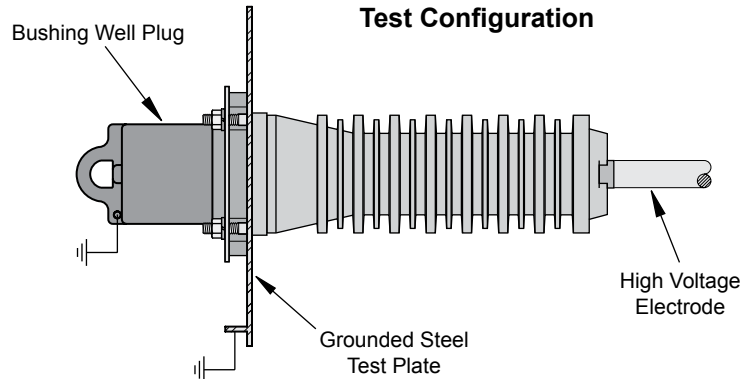

Installation Instructions

The #1102-235A2 Bushing Well requires a 3.5" diameter mounting hole and clamps in place with a #1900-CR4S or #1901-CR4S clamp ring utilizing four 0.3125"-18UNC x 1.25" weld studs on a 4.25" bolt circle. All mounting hardware is located on the elbow side of the equipment mounting plate to eliminate the possibility of reduced phase-to-ground clearance.

Every Elliott Bushing Well is tested at the factory, mounted in a grounded steel plate. A greased bushing well plug is installed in the well interface to accurately simulate operating conditions. To prevent contamination of the silicone grease, it is important to keep the protective cap in place until you are ready to install the bushing insert (or other device). Should the grease become contaminated, thoroughly clean the interface and reapply silicone grease before installing the bushing insert.

NOTE: *The shipping cap on the bushing well should be left in place to prevent contamination of the interface.*

1. The bushing well installs from the elbow side for easy installation.
2. A clamp ring is placed on the bushing.
3. Lock washers and lock nuts are installed on the studs. The nuts should be tightened in a uniform manner (rather than one-by-one in a random sequence). Do not apply more than 90 inch-pounds torque to each nut. The studs should be left unpainted to provide a connection from the shielding to the grounded mounting plate. If the bushing is mounted on an ungrounded or insulated plate (such as fiberglass) a ground strap should be attached to one of the mounting studs.

IMPORTANT:

Do not energize this bushing with only the shipping cap in place. To do so would lead to failure of the bushing and create a hazard to operating personnel. This product is designed to be used **only** when it is mated with an appropriate 200 Amp 35 kV Class bushing insert and elbow conforming to the latest revision of IEEE Standard 386. The bushing insert and elbow should be installed in accordance with the instructions supplied by the insert manufacturer.

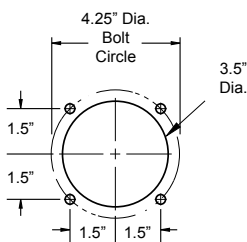

**Mounting Hole
For #1102-235A2**

0.3125"-18 x 1.25" Studs with
Elliott #1900-CR4S Clamp Ring

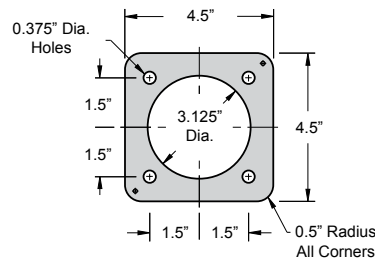

**Clamp Ring
#1900-CR4S**

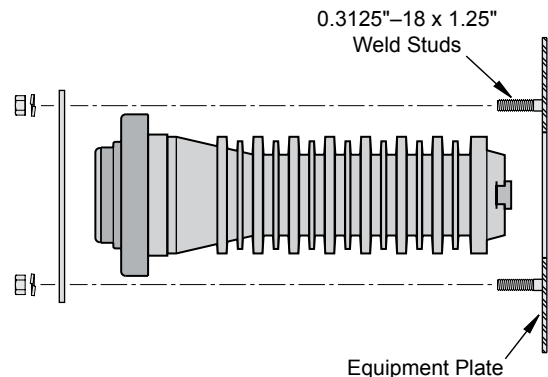

Equipment Plate

Elastimold® is a registered trademark of ABB Asea Brown Boveri Ltd.



35-kV Apparatus Bushing
"A" Series (clamp-in) for Elbow to Air-Insulated Service
200 Amp

Descriptive
Bulletin
1135-200
Page 4 2018

**If you do not find the design
you need**

PLEASE CONTACT

our REPRESENTATIVE or the FACTORY