

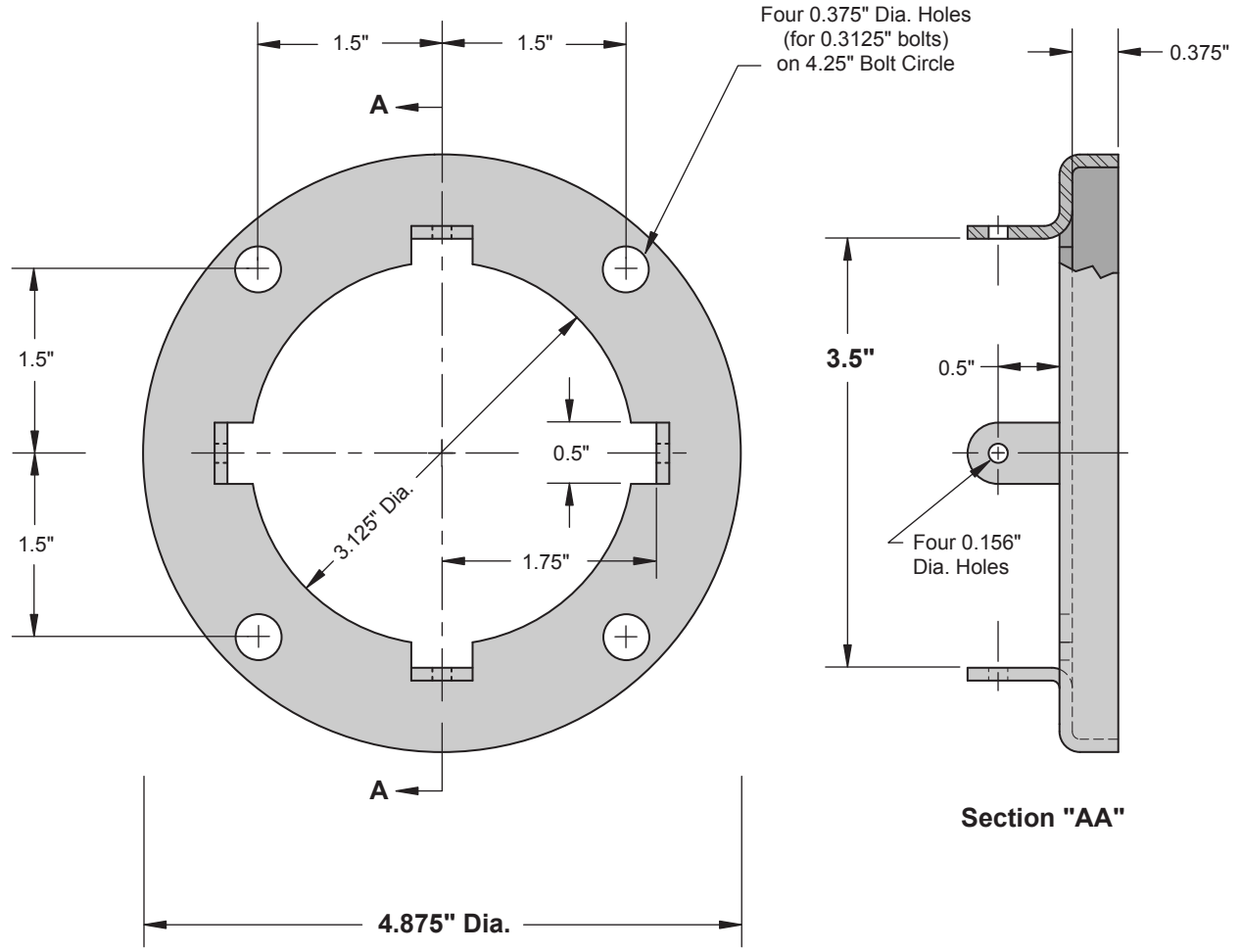

# Bushing Clamp Ring

For Elliott Air-Insulated Bushings

Descriptive Bulletin  
**1901**  
 Page 1 2015



**Recommended Mounting:**  
 Four 0.3125"-18 x 1.25"  
 Studs on 4.25" Bolt Circle

Catalog Number	Description	Material
1901-CR4S	Bushing Clamp Ring	12-gauge #304 Stainless Steel



**Bushing Clamp Ring**  
For Elliott Air-Insulated Bushings

Descriptive  
Bulletin  
**1901**  
Page 2 2015

**If you do not find the design  
you need**

**PLEASE CONTACT**

**our REPRESENTATIVE or the FACTORY**