



# Apparatus Insulators

Indoor - Outdoor  
Double Bolt Series 0.375"-16 Inserts

Descriptive  
Bulletin  
**2350-004**  
Page 1     2015

## Extra Heavy Duty

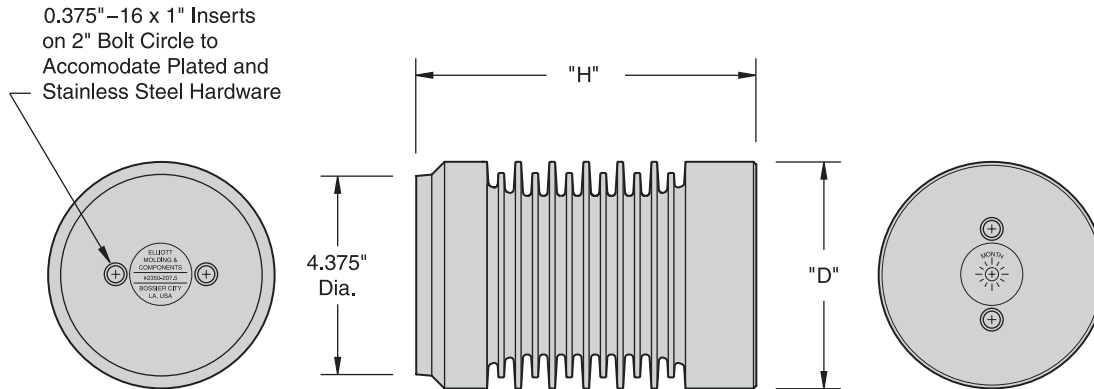

### ELRIM Cycloaliphatic Epoxy Provides:

- Nontracking, self-scouring, nonweathering performance
- Superior dielectric strength, dielectric loss and power factor
- Choice of shapes allows design innovation
- Mechanical and thermal toughness
- Shatter-free arc flashover performance
- Oil resistant

### Elliott Design Provides:

- Cast-in-place inserts without metal end caps
- Contamination resistant Elliott square-edge skirts
- Generous dry arcing (strike) distance
- Increased leakage distance to resist contamination
- Thermal cycling withstand from +200° F to -200° F
- High strength - field proven performance
- Experience with cycloaliphatic epoxy since 1975

The extra-heavy-duty double-bolt apparatus insulator provides two 0.375"-16 Inserts on a 2-inch bolt circle in the top and bottom. The insulator may be used as a direct replacement for porcelain and non-porcelain insulators. This unusually compact design may be mounted in any position. The unique Elliott square-edge skirt design provides unusually high performance in contaminated conditions - wet or dry. High cantilever strength and the other superior qualities of cycloaliphatic epoxy make this insulator a high-performance component.

### Important:

*Water that accumulates in the inserts and then freezes will damage epoxy insulators. When insulators are to be installed outdoors, inserts must be partially filled with no-oxide compound (or similar material) to prevent moisture accumulation in the inserts.*

### Ratings and Dimensions of Extra-Heavy-Duty Apparatus Insulators

Catalog Number	Nominal Voltage kV	Withstand Test Voltage Kilovolts			"H" Height Inches	"D" Diameter Inches	Minimum Leakage Inches	Minimum Strike Inches
		Impulse 1.2 x 50	One Min. Dry.	10 Sec. Dew				
2350-206	15	95	50	30	6	5	14	6
2350-207.5	25	125	60	45	7.5	5	20	7.5
2350-208.5	25	125	70	50	8.5	5	20.75	8.5
2350-210	35	150	80	60	10	5	29	10
2350-214	35	200	95	80	14	5.25	44.5	14
2350-218	46	250	120	100	18	6	60	18



# Apparatus Insulators

Indoor - Outdoor  
Double Bolt Series 0.375"-16 Inserts

Descriptive  
Bulletin  
**2350-004**  
Page 2    2015

0.375"-16 x 1" Embedded Inserts  
on 2" Bolt Circle to Accomodate  
Plated and Stainless Steel Hardware

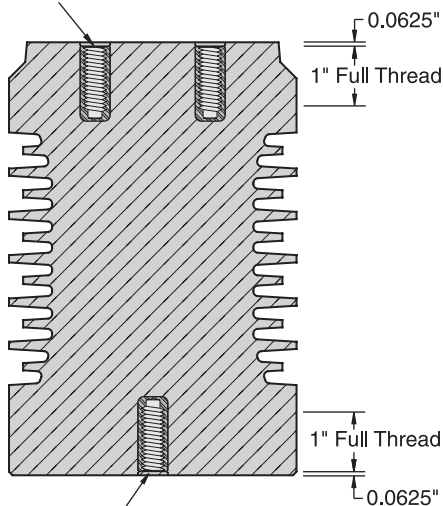

0.375"-16 x 1" Embedded Inserts  
on 2" Bolt Circle to Accomodate  
Plated and Stainless Steel Hardware

### Typical Construction

**Important:**

*Water that accumulates in the inserts and then freezes will damage epoxy insulators. When insulators are to be installed outdoors, inserts must be partially filled with no-oxide compound (or similar material) to prevent moisture accumulation in the inserts.*

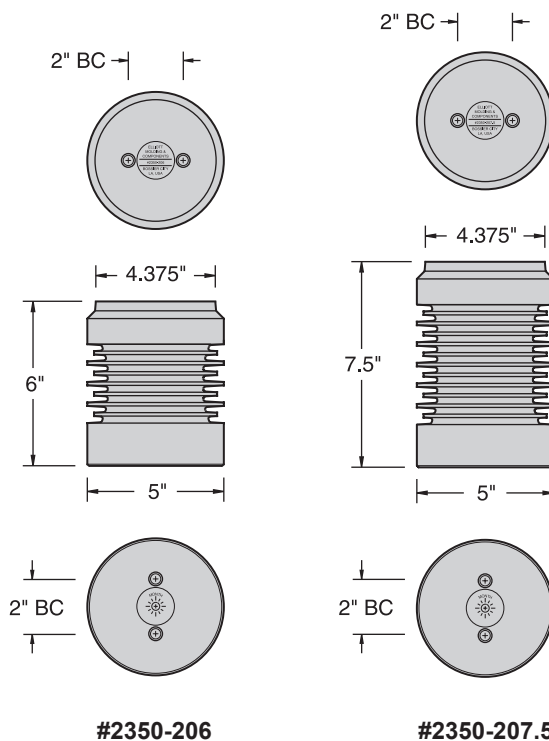

Catalog Number	2350-206	2350-207.5
Electrical Rating, kV		
Nominal Voltage	15	25
BIL	95	125
AC Withstand - 1 Min. Dry	50	60
AC Withstand - 10 Sec. Dew	30	45
Height of Insulator, Inches	6	7.5
Leakage Distance, Inches	14	20
Dry Arcing Distance, Inches	6	7.5
Mechanical-Strength Rating, Pounds		
Cantilever, Ultimate 2.5 inches above top*	3,000	3,000
Tensile, Pounds	10,000	10,000
Torsion, Inch-Pounds	8,000	8,000
Compression, Pounds	20,000	20,000
Insert Thread Size	0.375"-16	0.375"-16
Net Weight, Pounds (kg)	6.42 (2.91)	7.57 (3.43)

\* To attain their rated cantilever strengths, insulators must be mounted with the large end on a flat surface that is at least as wide as the diameter of the base of the insulator. Furthermore, the mounting surface must be free of protrusions, such as lumps from galvanizing, to prevent cracking of the insulator when mounting bolts are tightened.

**Apparatus Insulators**  
Indoor - Outdoor  
Double Bolt Series 0.375"-16 Inserts

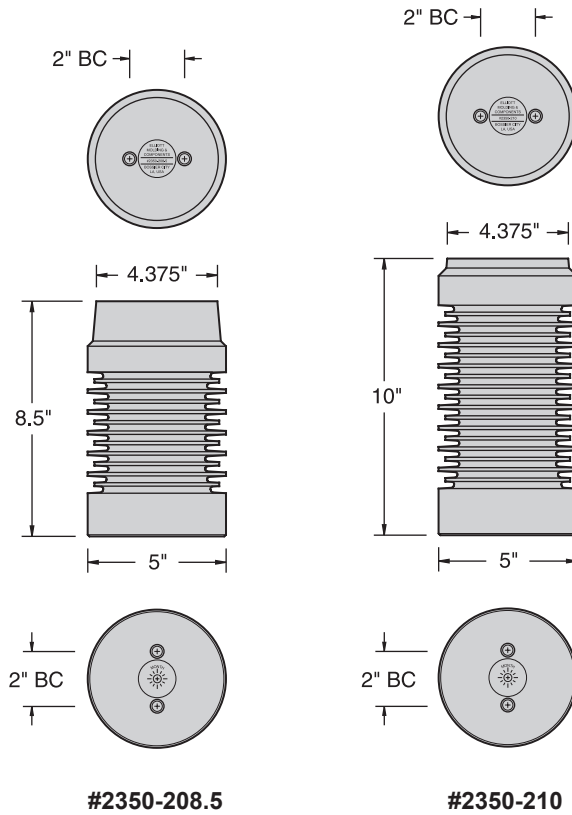

Catalog Number	2350-208.5	2350-210
Electrical Rating, kV		
Nominal Voltage	25	35
BIL	125	150
AC Withstand - 1 Min. Dry	70	80
AC Withstand - 10 Sec. Dew	50	60
Height of Insulator, Inches	8.5	10
Leakage Distance, Inches	20.75	29
Dry Arcing Distance, Inches	8.5	10
Mechanical-Strength Rating, Pounds		
Cantilever, Ultimate 2.5 inches above top*	3,000	2,500
Tensile, Pounds	12,000	12,000
Torsion, Inch-Pounds	10,000	10,000
Compression, Pounds	20,000	20,000
Insert Thread Size	0.375"-16	0.375"-16
Net Weight, Pounds (kg)	8.79 (3.99)	9.49 (4.30)

**Apparatus Insulators**  
Indoor - Outdoor  
Double Bolt Series 0.375"-16 Inserts

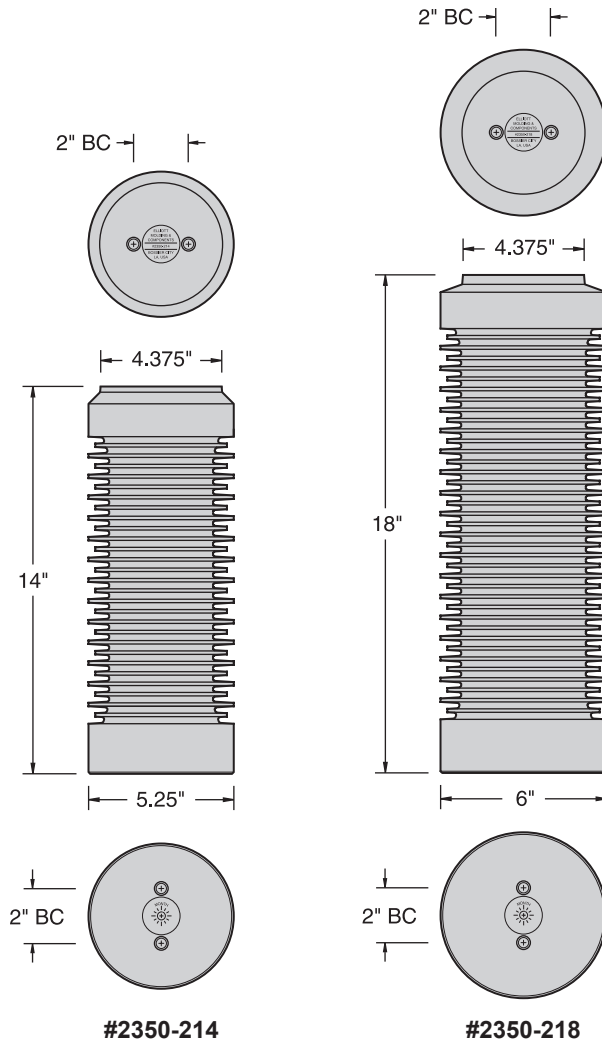

Catalog Number	2350-214	2350-218
Electrical Rating, kV		
Nominal Voltage	35	46
BIL	200	250
AC Withstand - 1 Min. Dry	95	120
AC Withstand - 10 Sec. Dew	80	100
Height of Insulator, Inches	14	18
Leakage Distance, Inches	44.5	60
Dry Arcing Distance, Inches	14	18
Mechanical-Strength Rating, Pounds		
Cantilever, Ultimate 2.5 inches above top*	2,000	2,000
Tensile, Pounds	12,000	14,000
Torsion, Inch-Pounds	10,000	12,000
Compression, Pounds	20,000	20,000
Insert Thread Size	0.375"-16	0.375"-16
Net Weight, Pounds (kg)	13.80 (6.26)	22.30 (10.12)